

H.F. DOR
WATER

ILLUSTRATION BOOKLET

Part of 595-2969-02

PARTS PICTORIAL

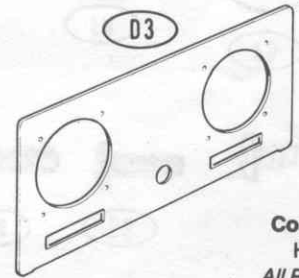
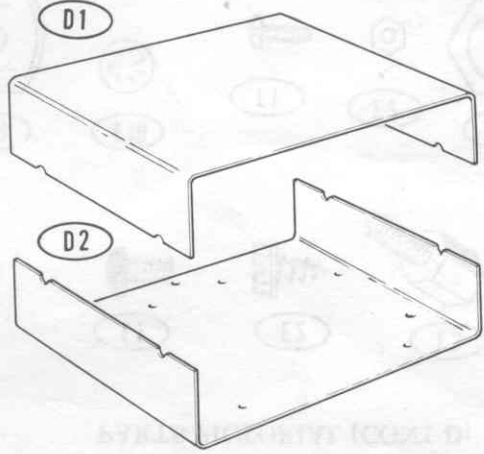
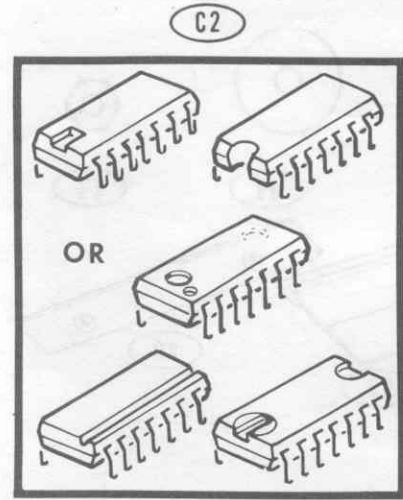
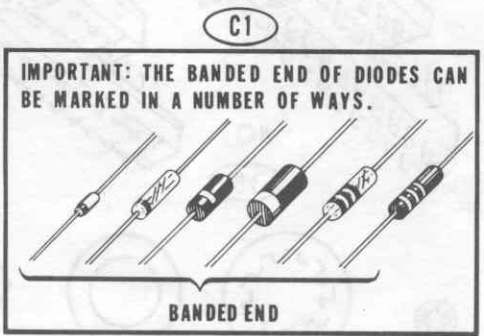
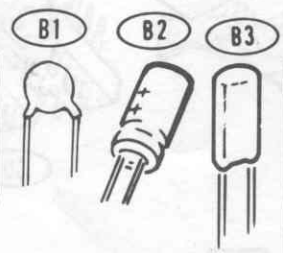
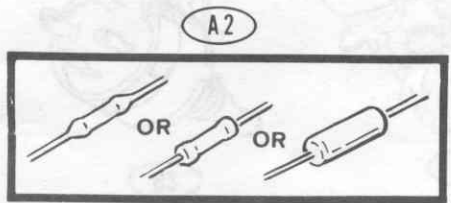
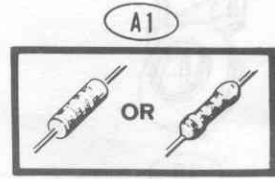

Copyright © 1983
Heath Company
All Rights Reserved
Model HM-2140-A Printed in the United States of America

PARTS PICTORIAL (CONT'D)

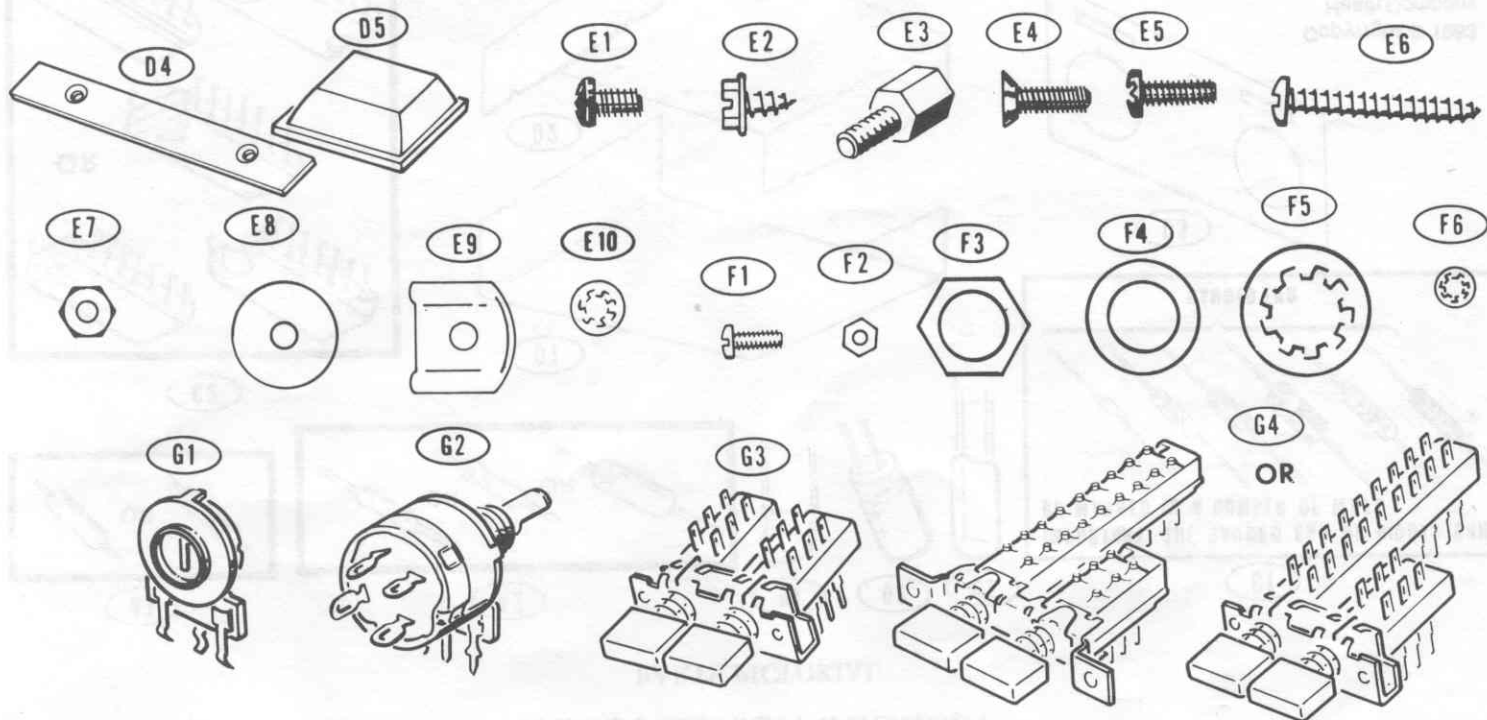

PARTS PICTORIAL (CONT'D)

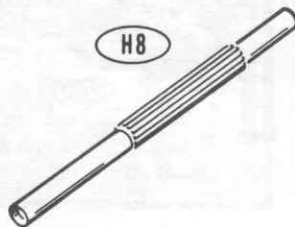
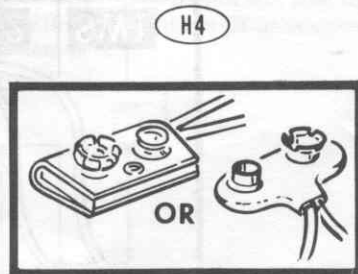
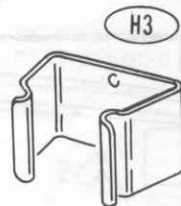
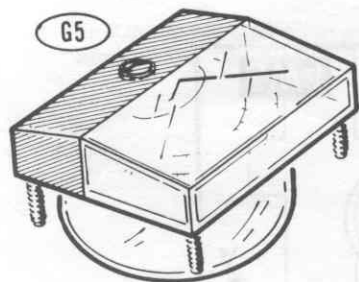

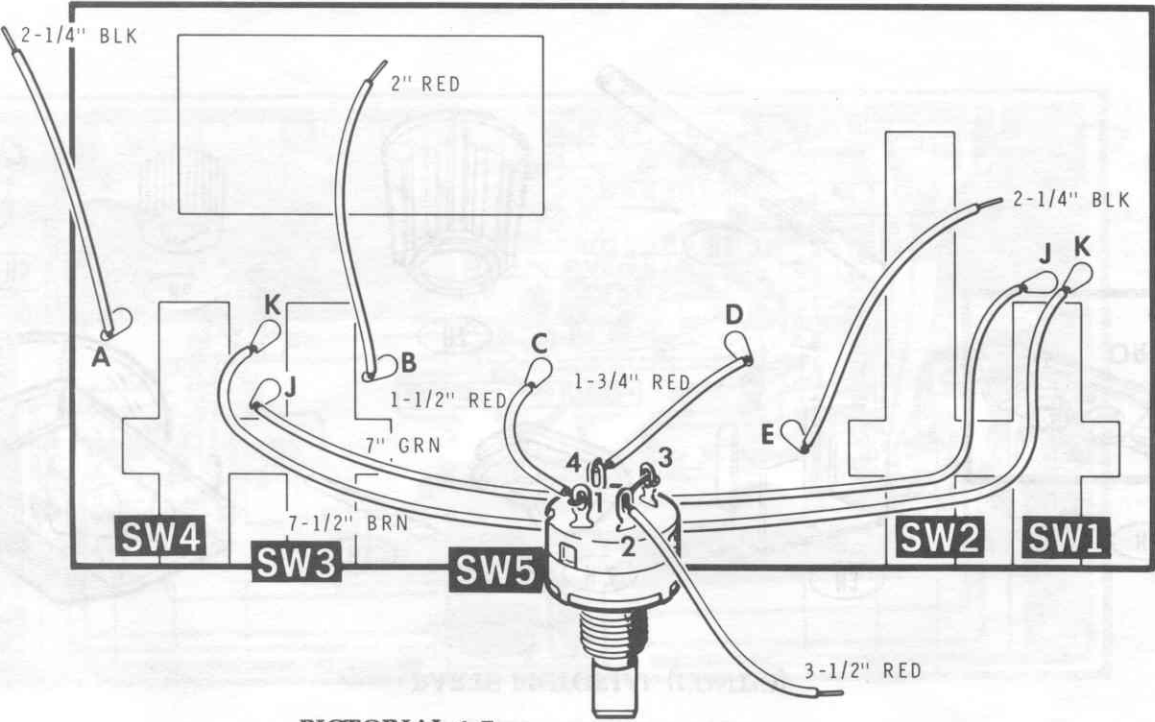

PICTORIAL 1-7

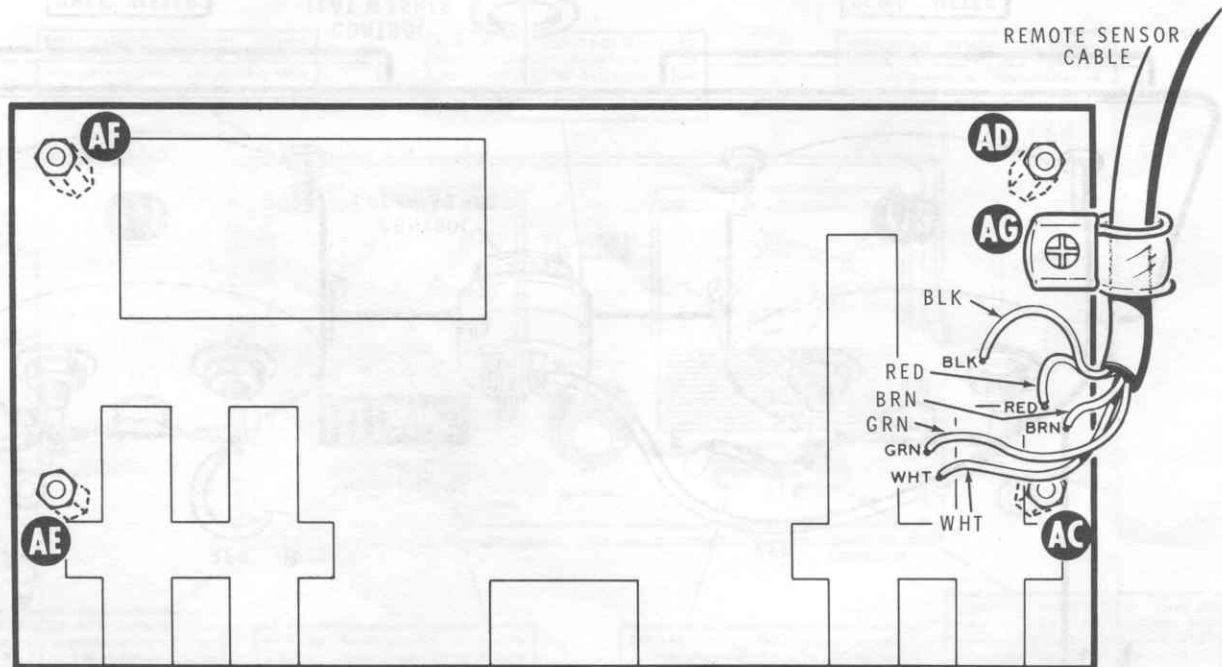

PICTORIAL 1-8

CIRCUIT BOARD

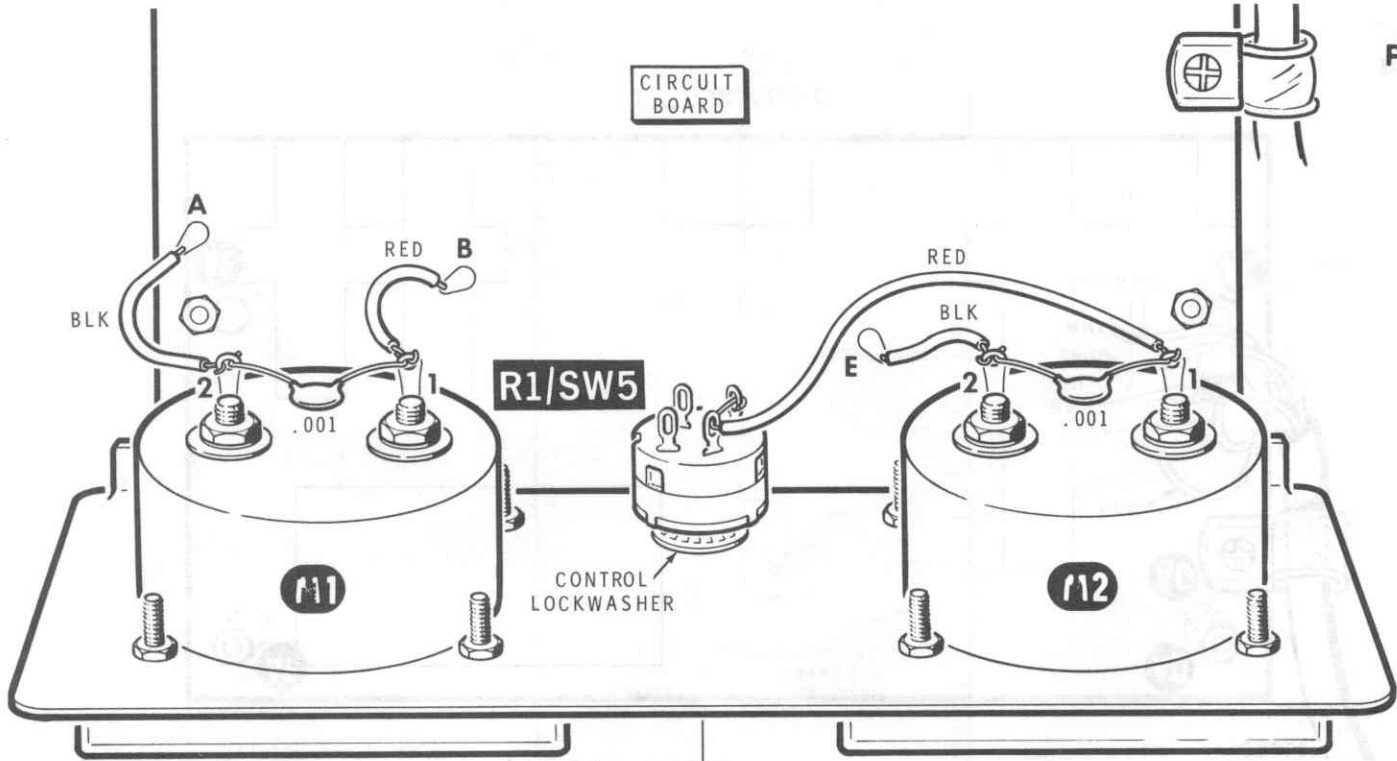

R1/SW5

"REF" METER

CONTROL
FLAT WASHER

CONTROL
NUT

"FWD" METER

PICTORIAL 2-1

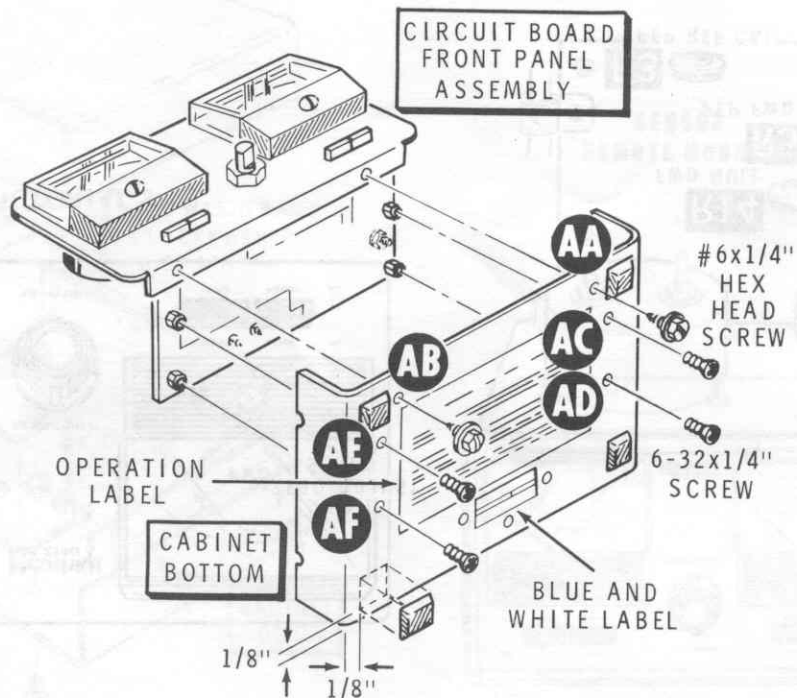

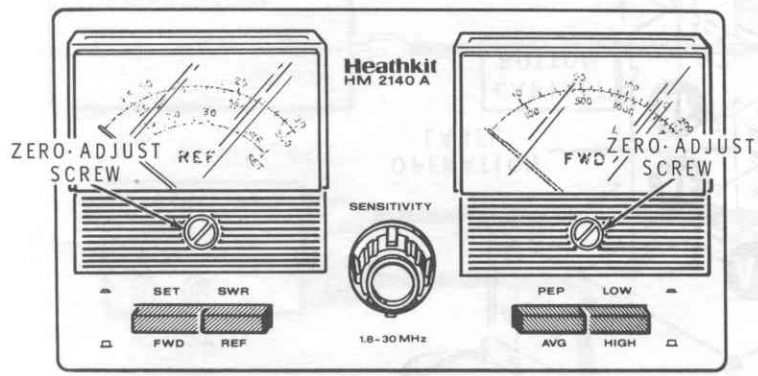

PICTORIAL 3-1

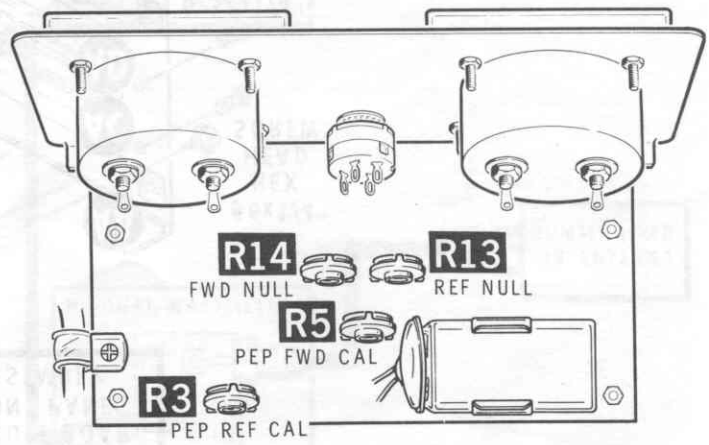

PICTORIAL 3-2

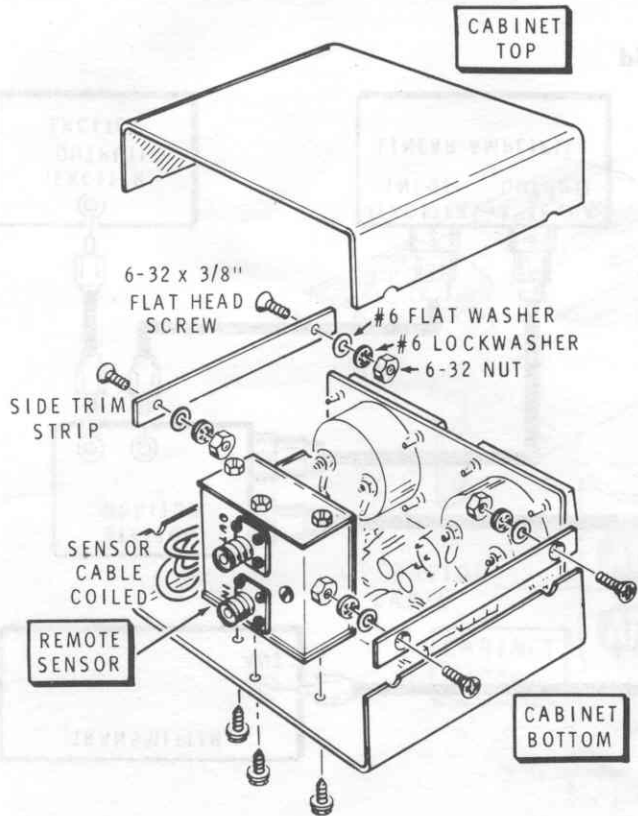

PICTORIAL 4-1

SENSOR
REMOTE MOUNTING

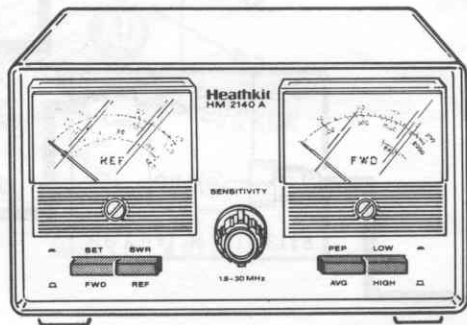
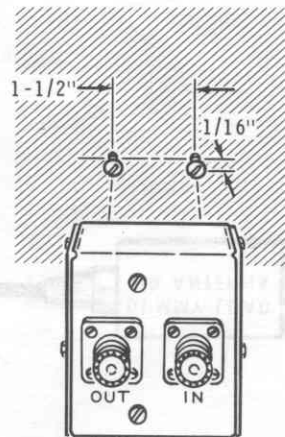

PICTORIAL 4-2

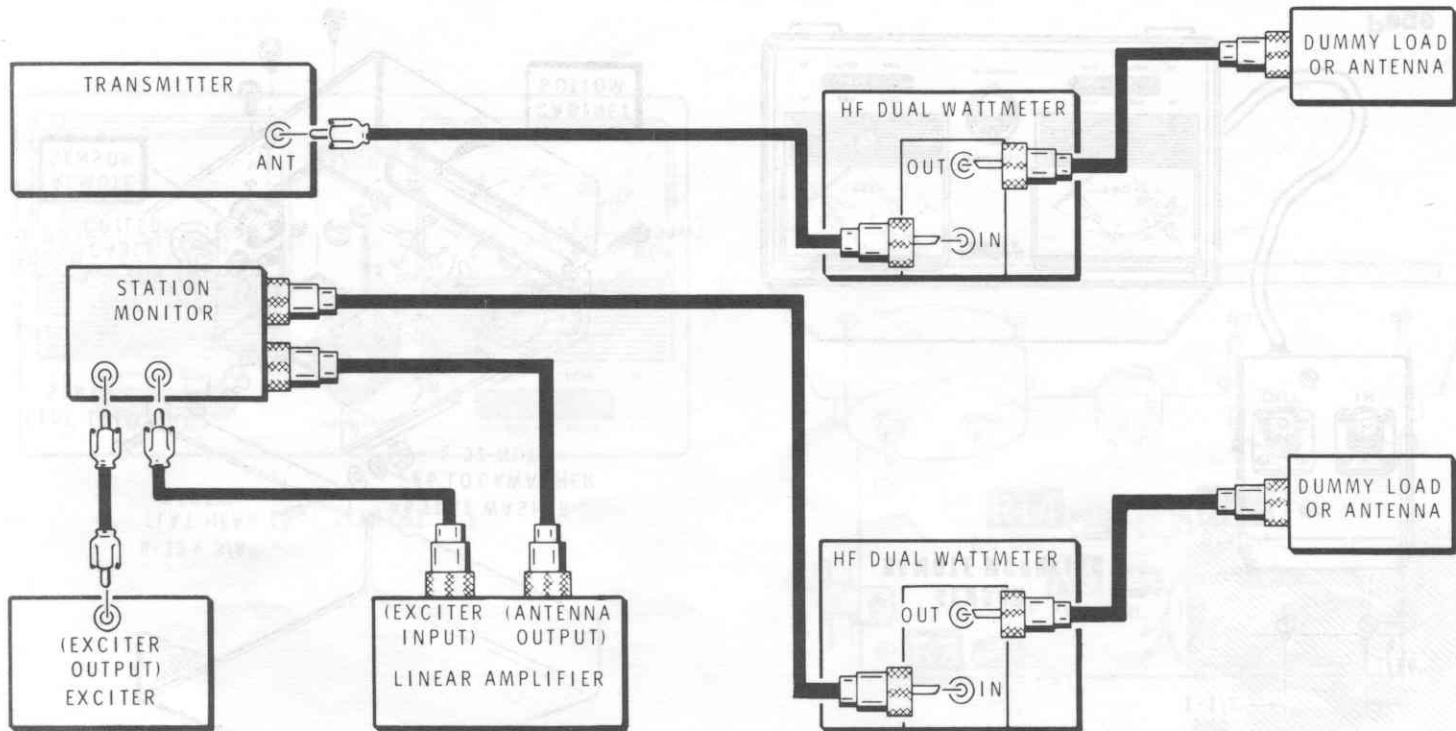

PICTORIAL 5-1

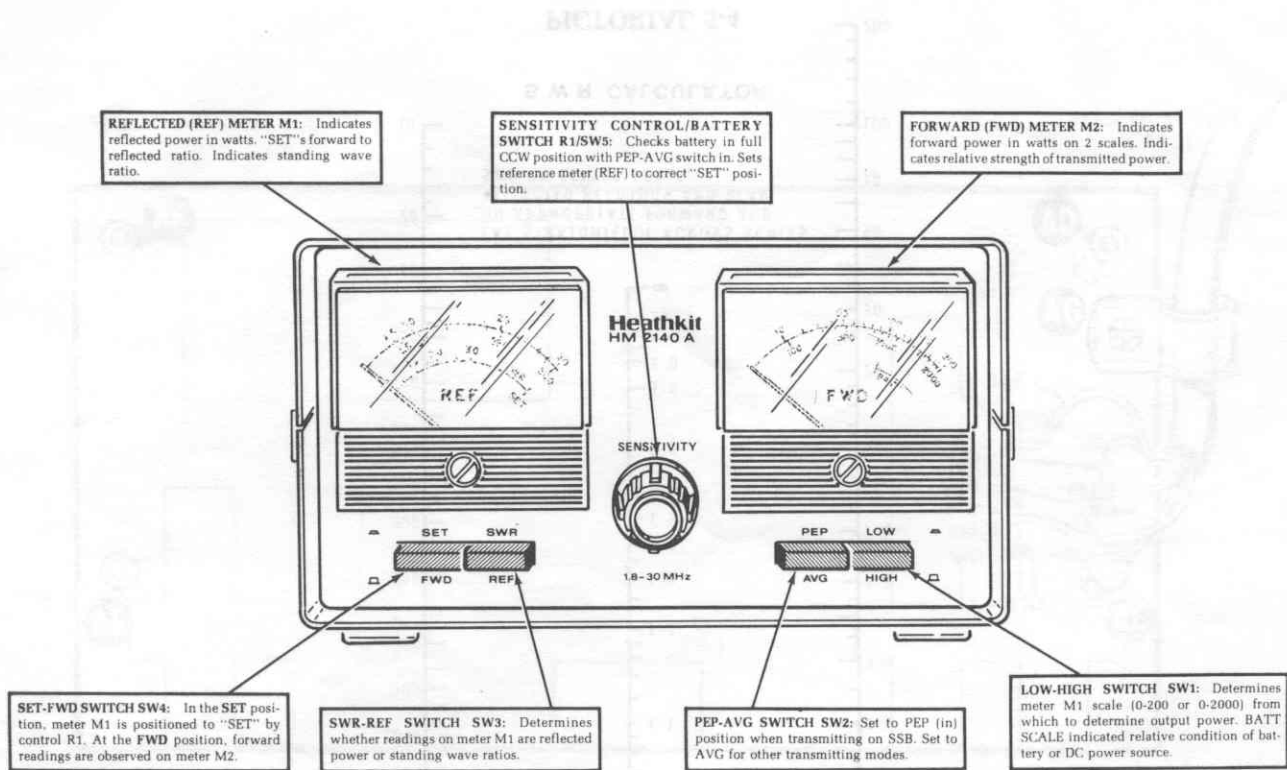

PICTORIAL 5-2

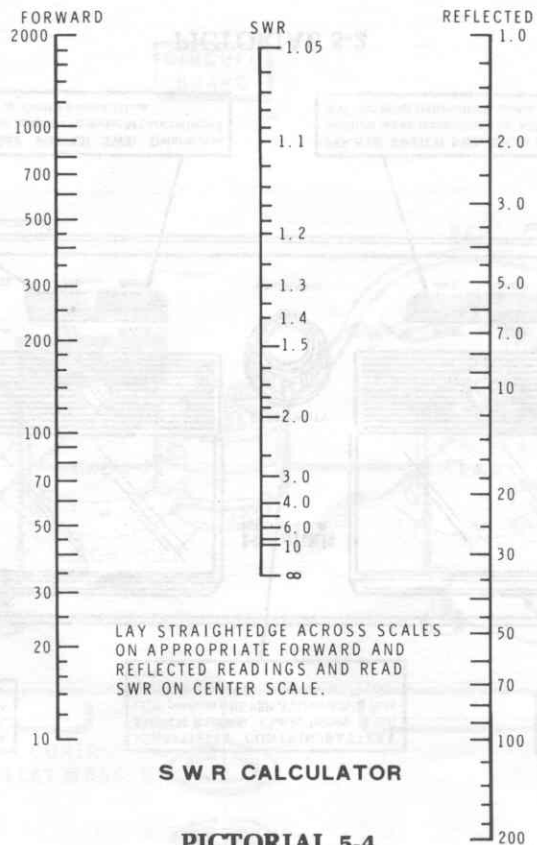

CIRCUIT BOARD X-RAY VIEWS

NOTE: To find the PART NUMBER of a component for the purpose of ordering a replacement part:

- Find the circuit component number (R7, C3, etc.) on the "Circuit Board X-Ray View."
- Locate this same number in the "Circuit Component Number" column of the "Parts List."
- Adjacent to the circuit component number, you will find the PART NUMBER and DESCRIPTION, which must be supplied when you order a replacement part.

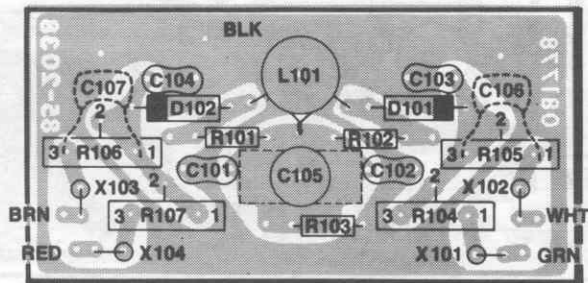

SENSOR CIRCUIT BOARD*

Shown from Component Side

*NOTE: This circuit board is inside the sealed Remote Sensor assembly. To tamper with the assembly or circuit board may void the Warranty.

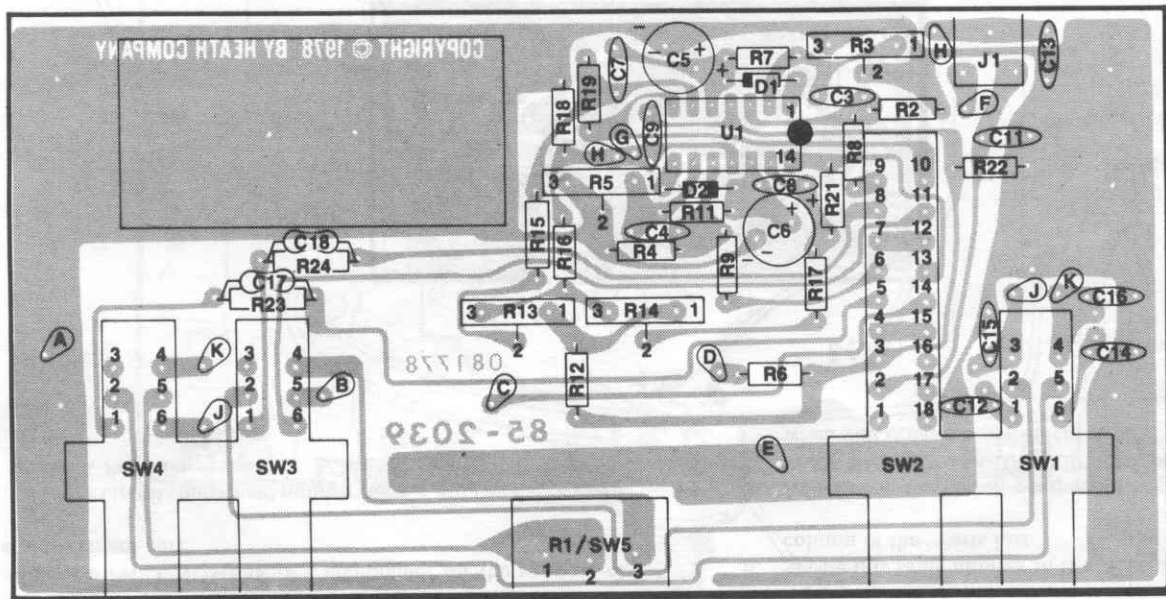

SWITCH CIRCUIT BOARD

Shown from Component Side