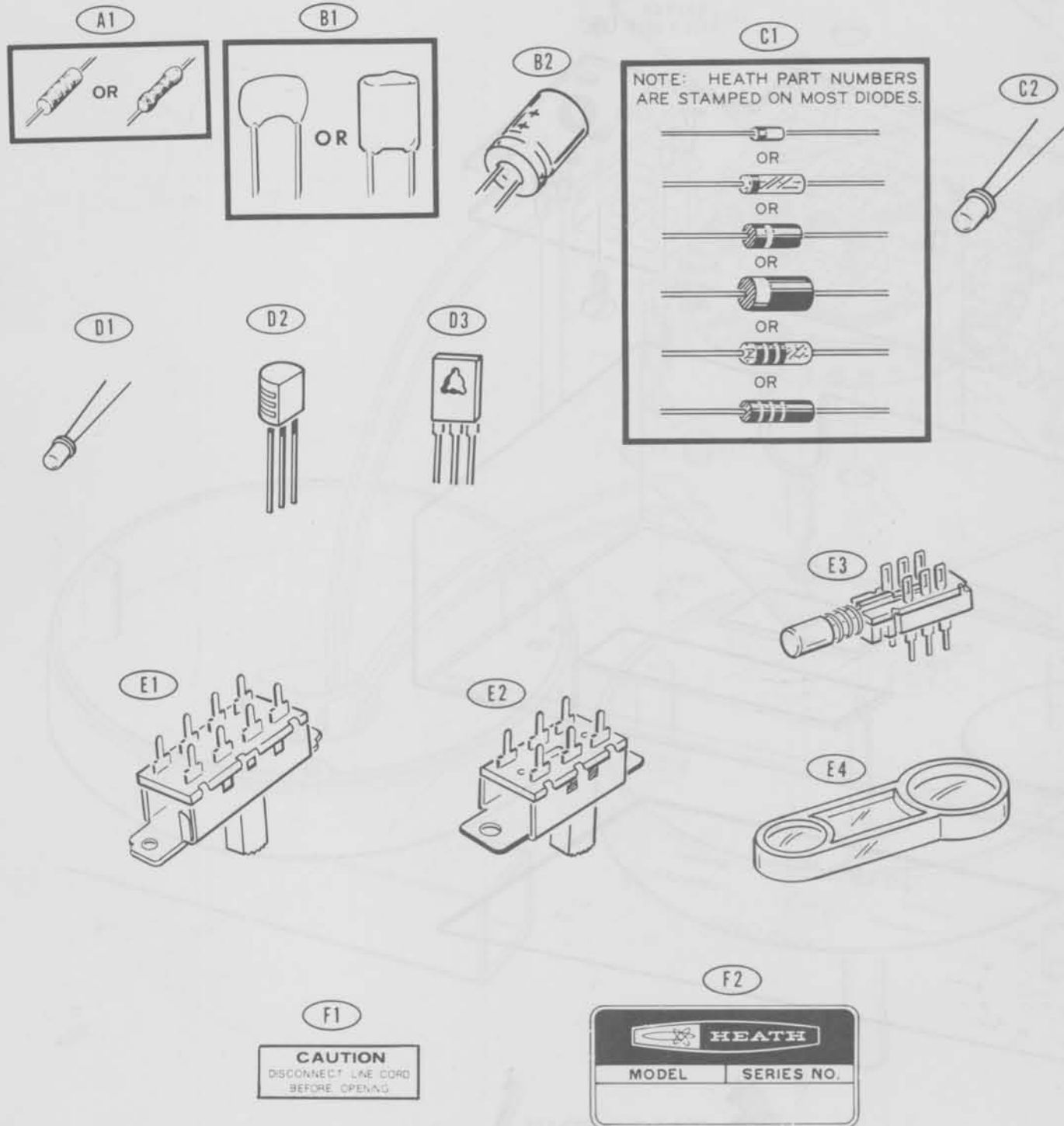

ILLUSTRATION BOOKLET

Part of 595-1999-11

PARTS PICTORIAL #1



PARTS PICTORIAL #2

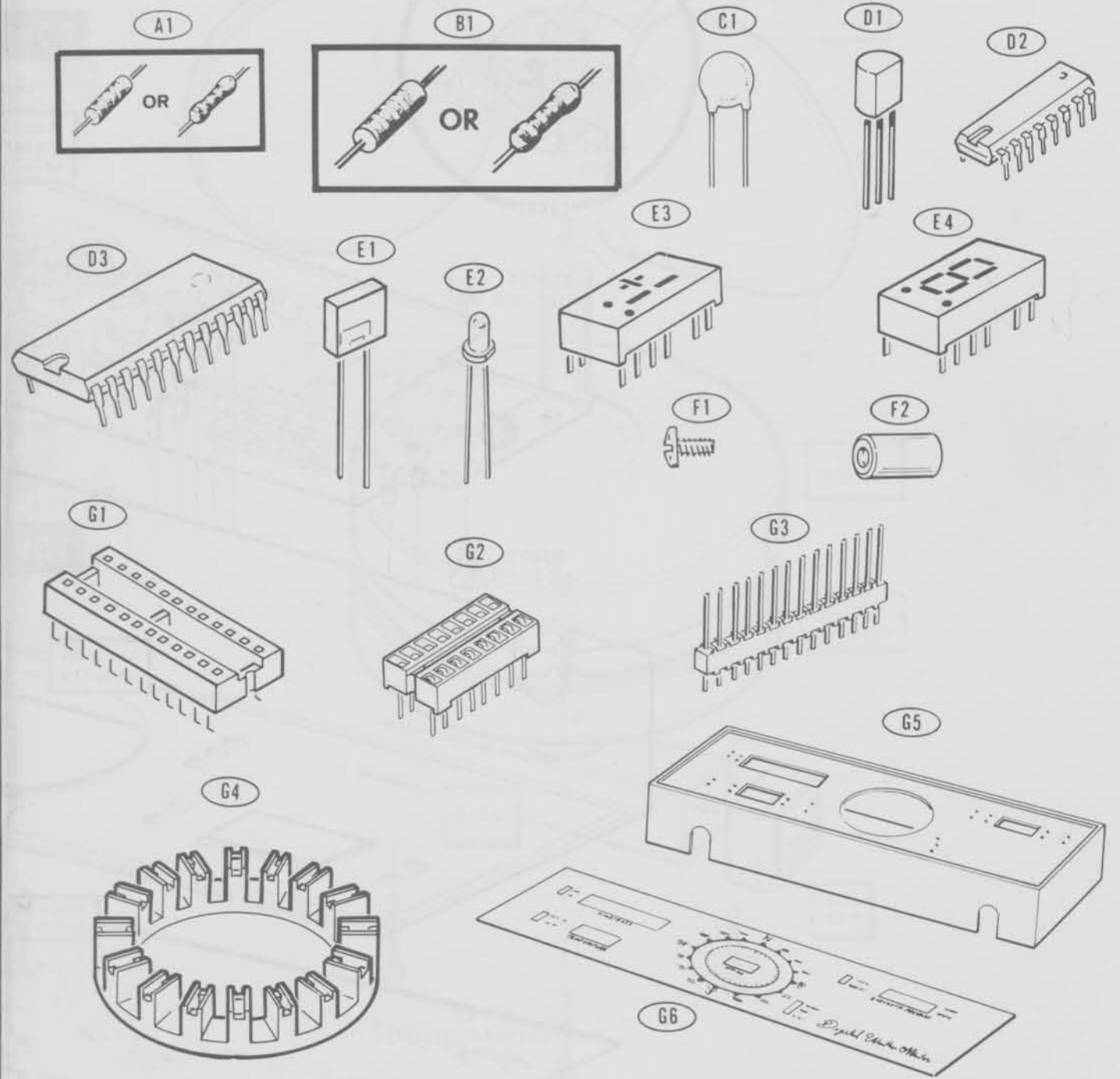

Model ID-4001 Assembly

Copyright © 1978
Heath Company
All Rights Reserved
Printed in the United States of America

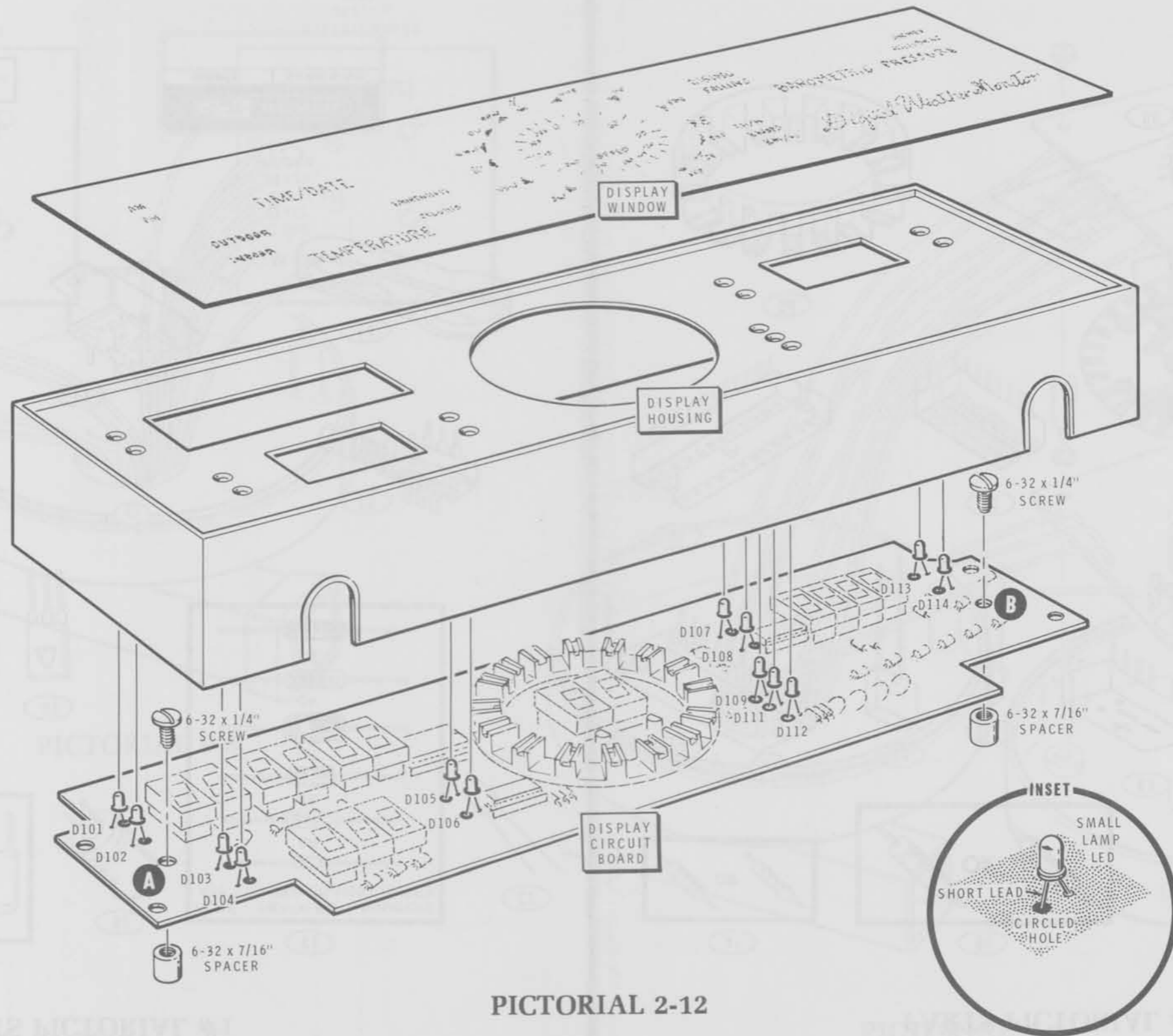

PICTORIAL 2-12

PARTS PICTORIAL #3

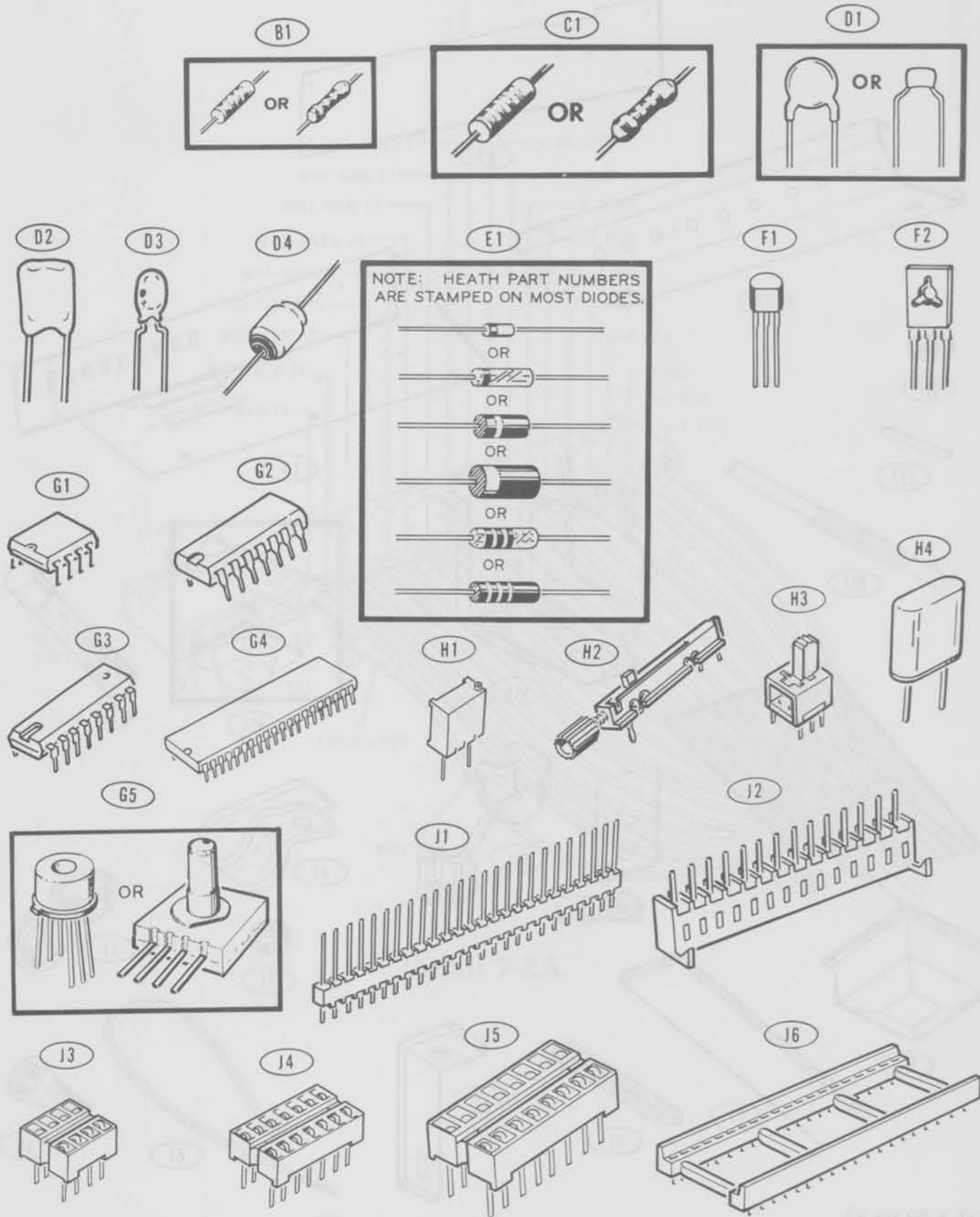

FRONT PANEL/CHASSIS PARTS PICTORIAL

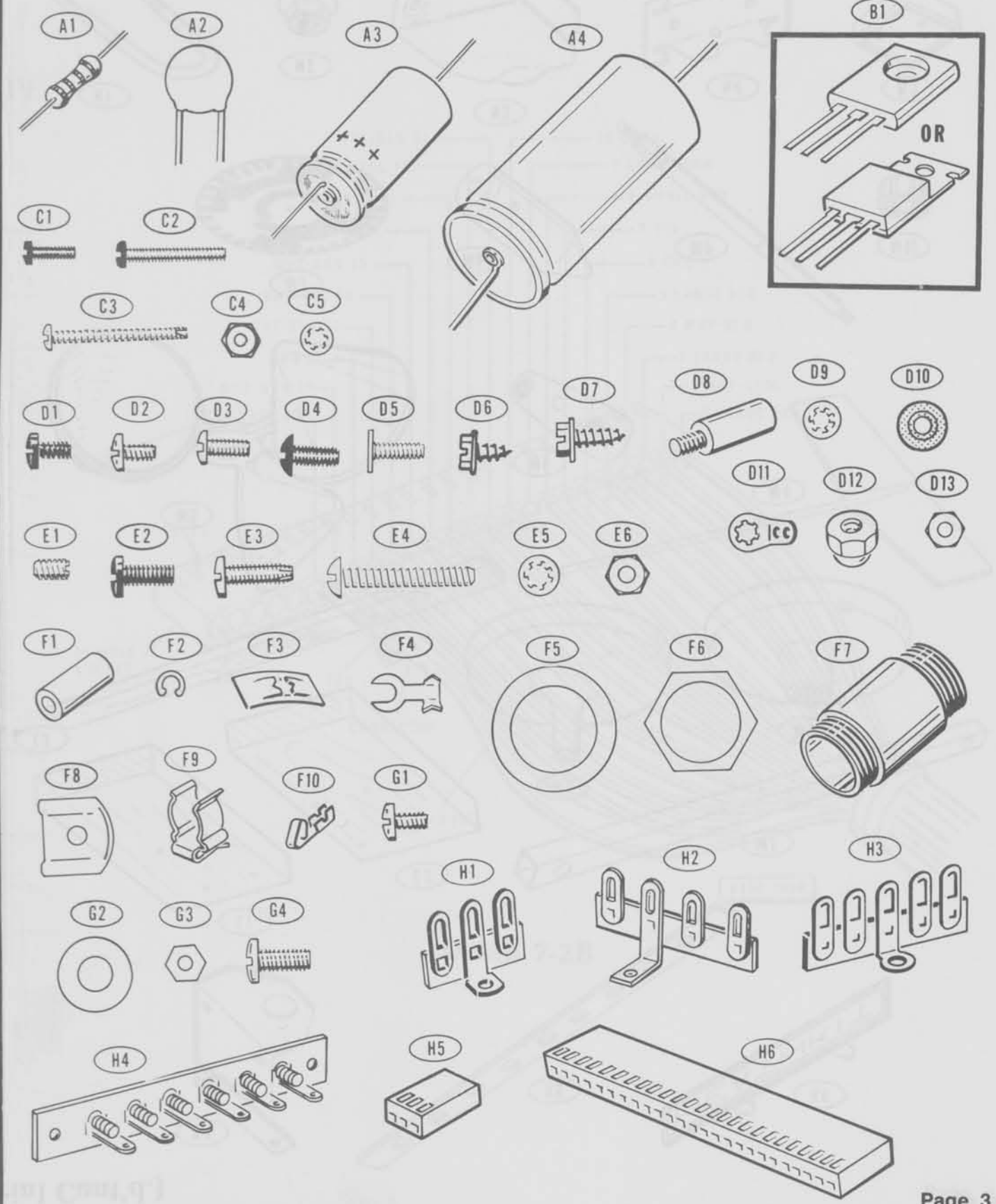

(Parts Pictorial Cont'd.)

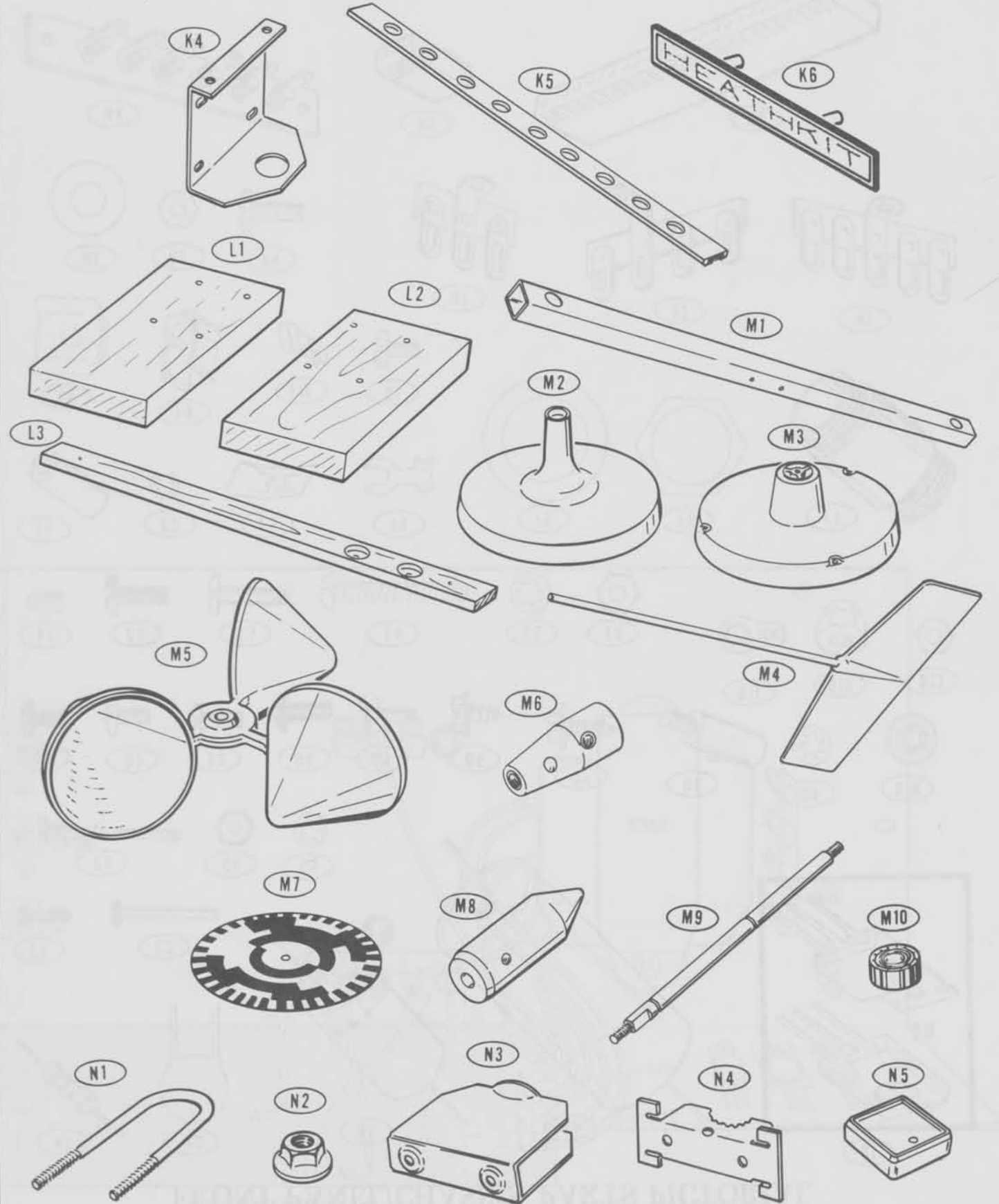
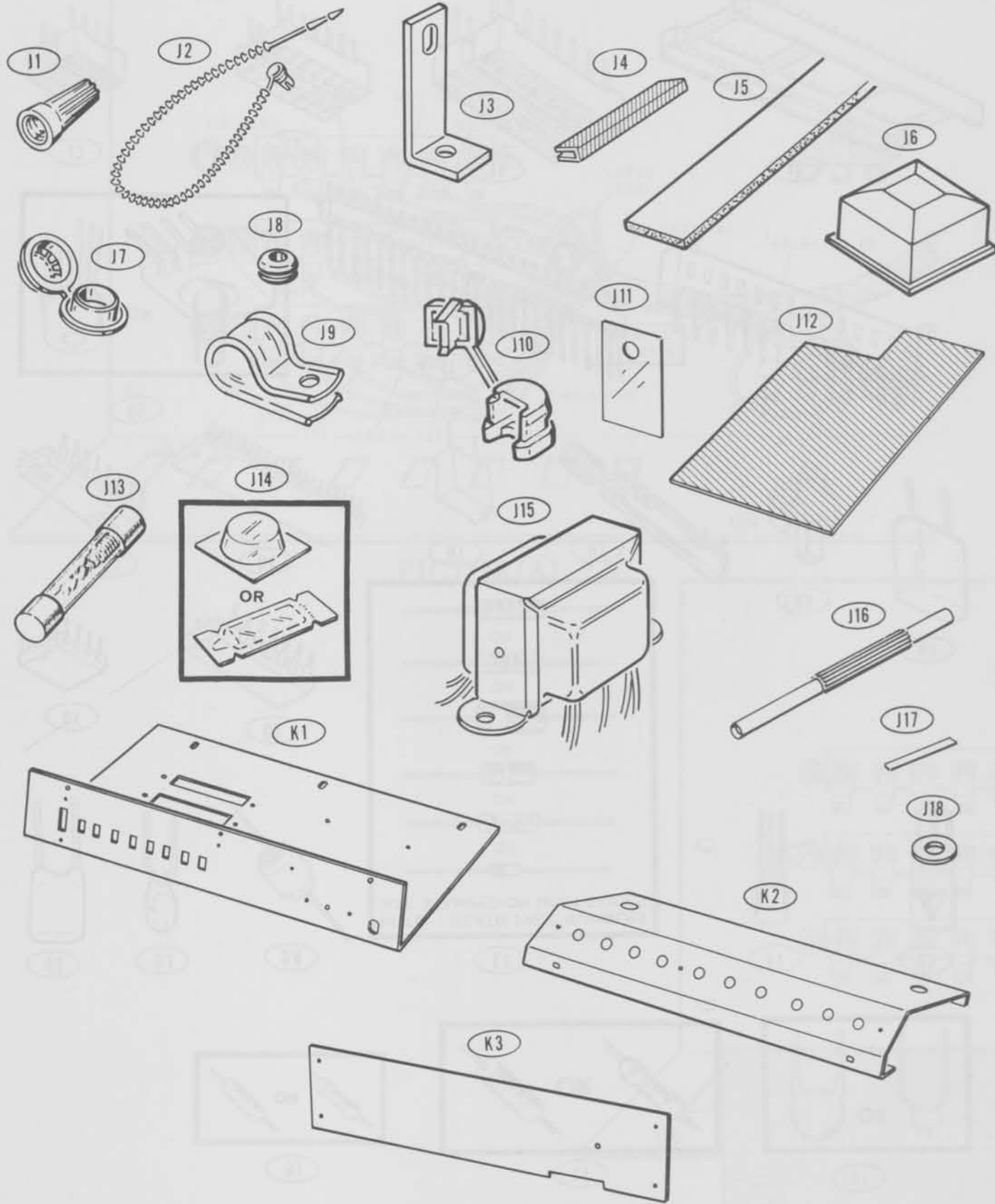

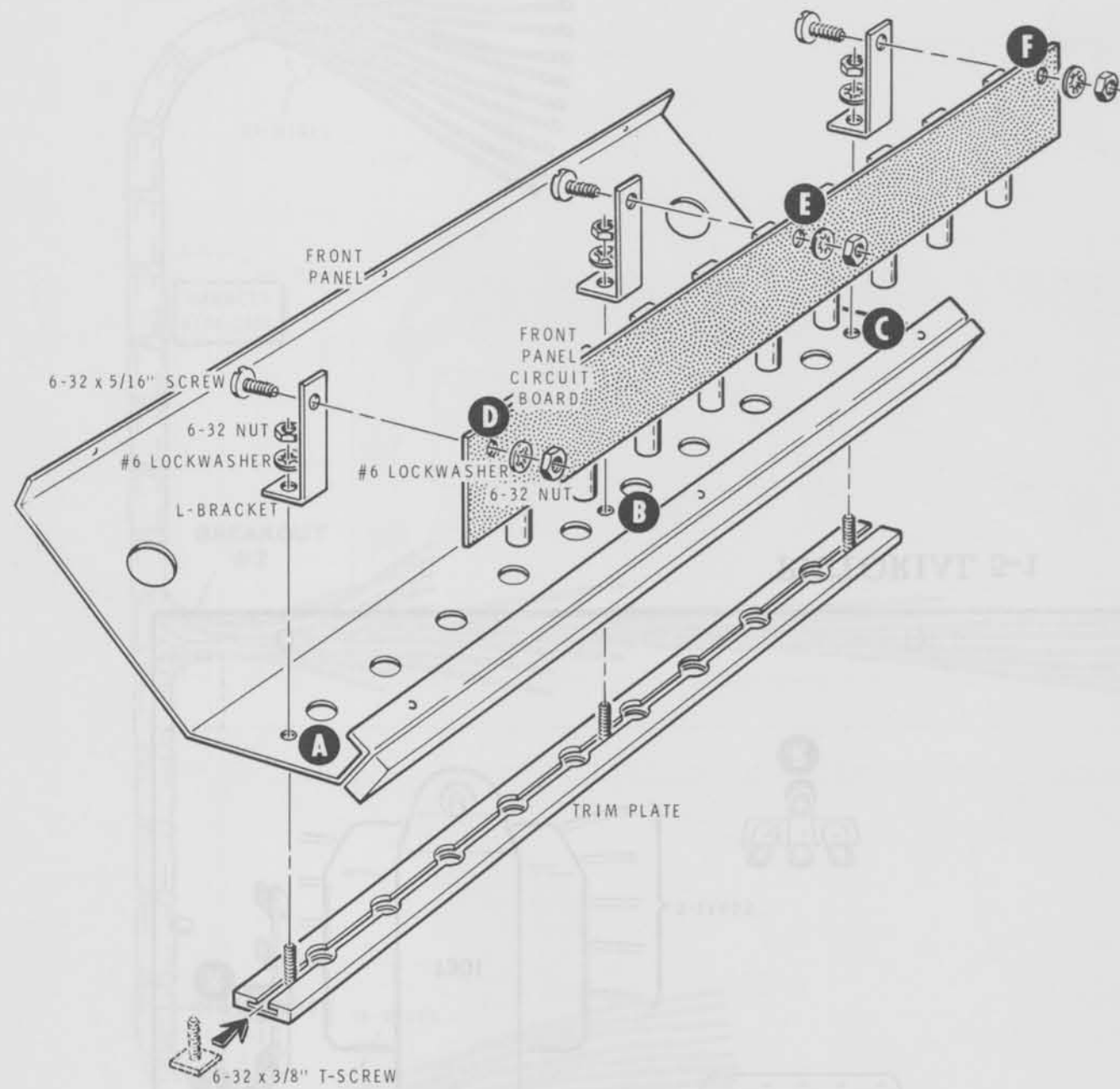

PICTORIAL 4-2

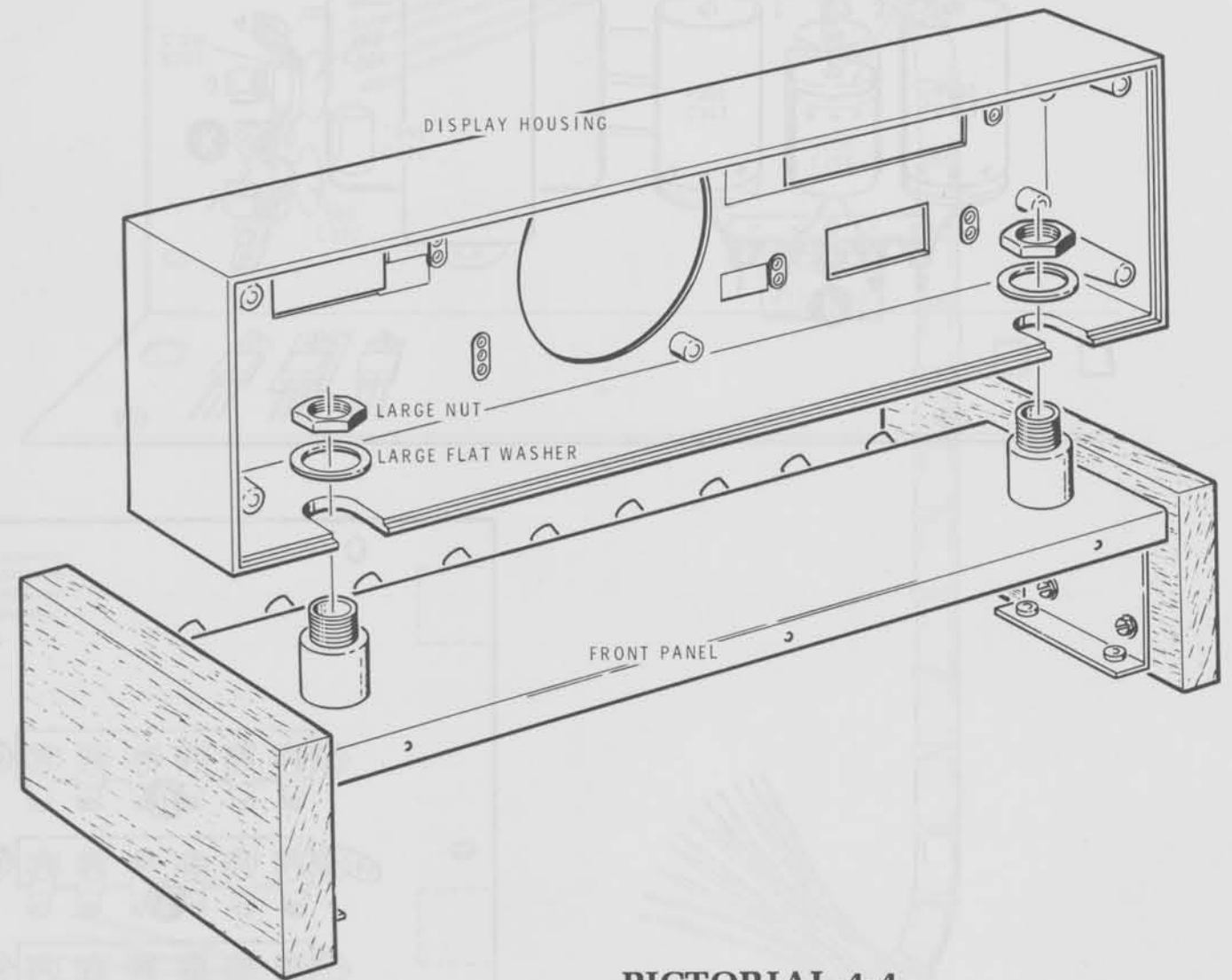

PICTORIAL 4-4

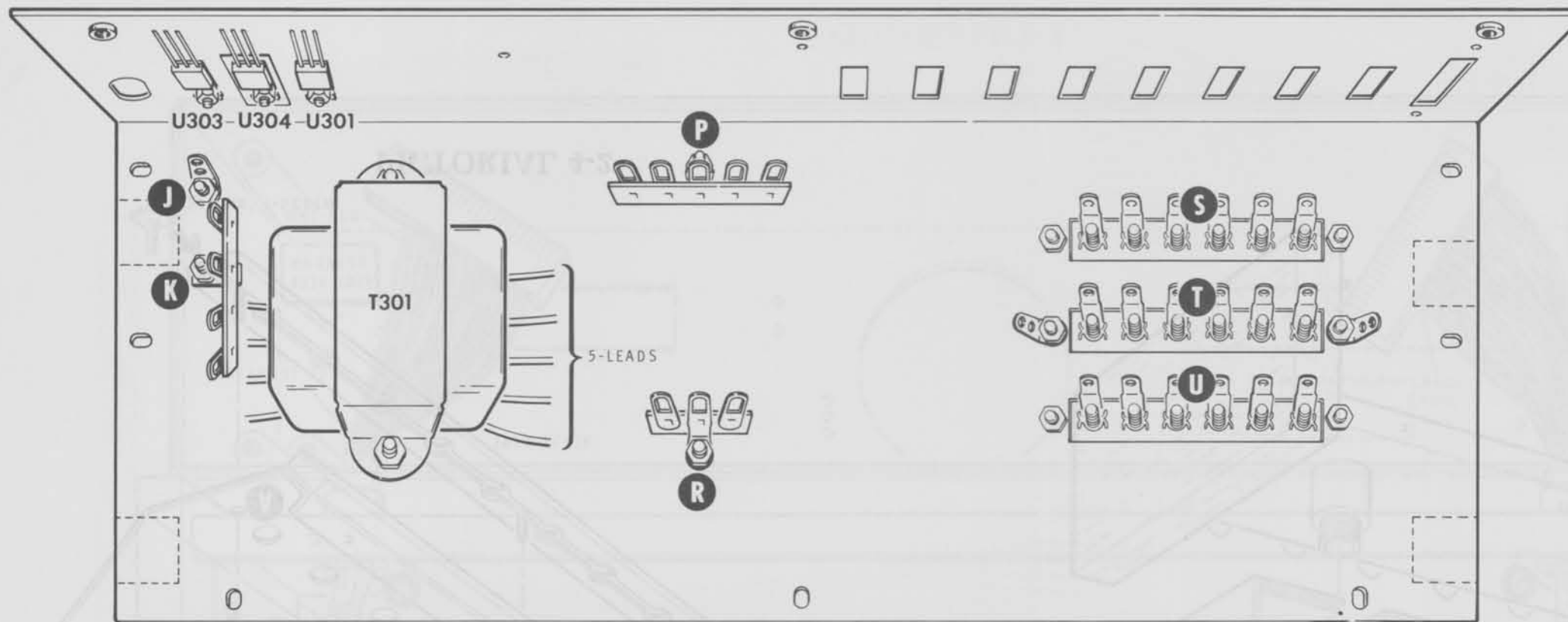

PICTORIAL 5-1

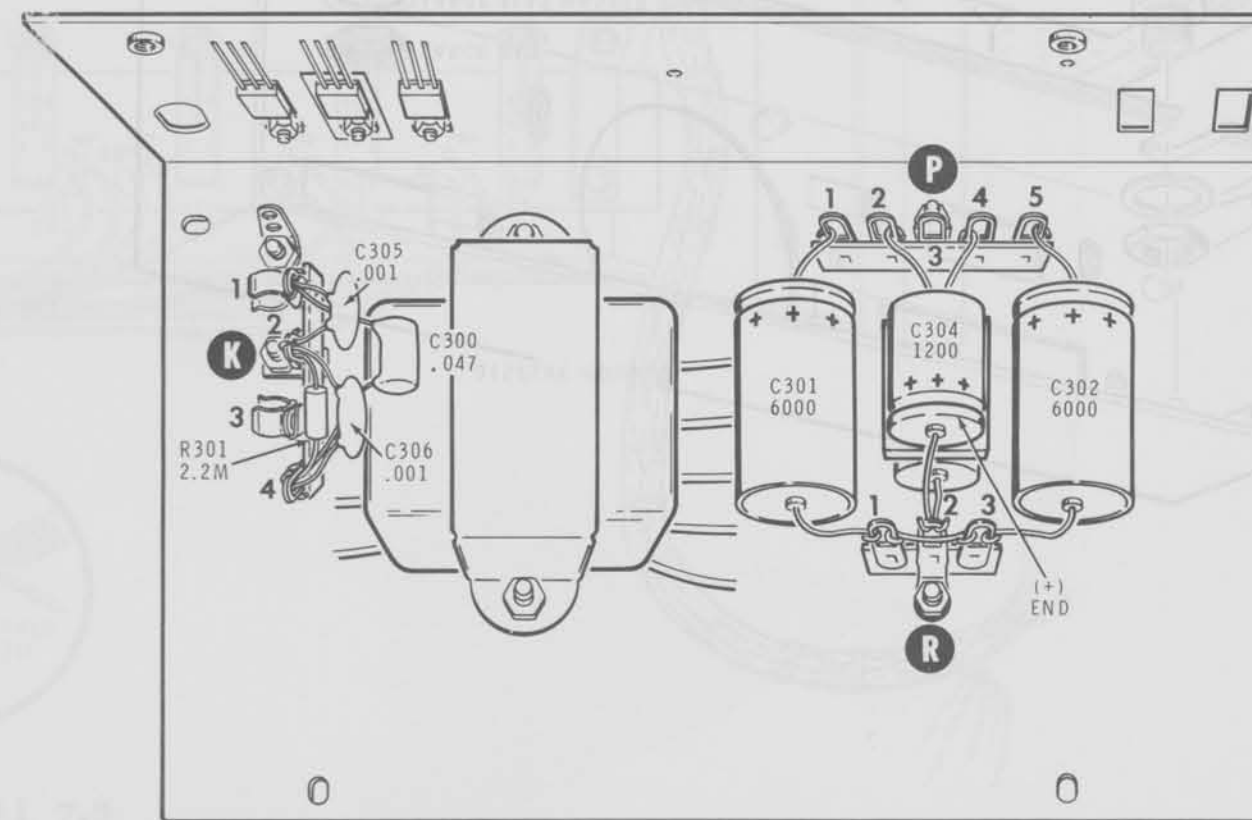

PICTORIAL 6-1

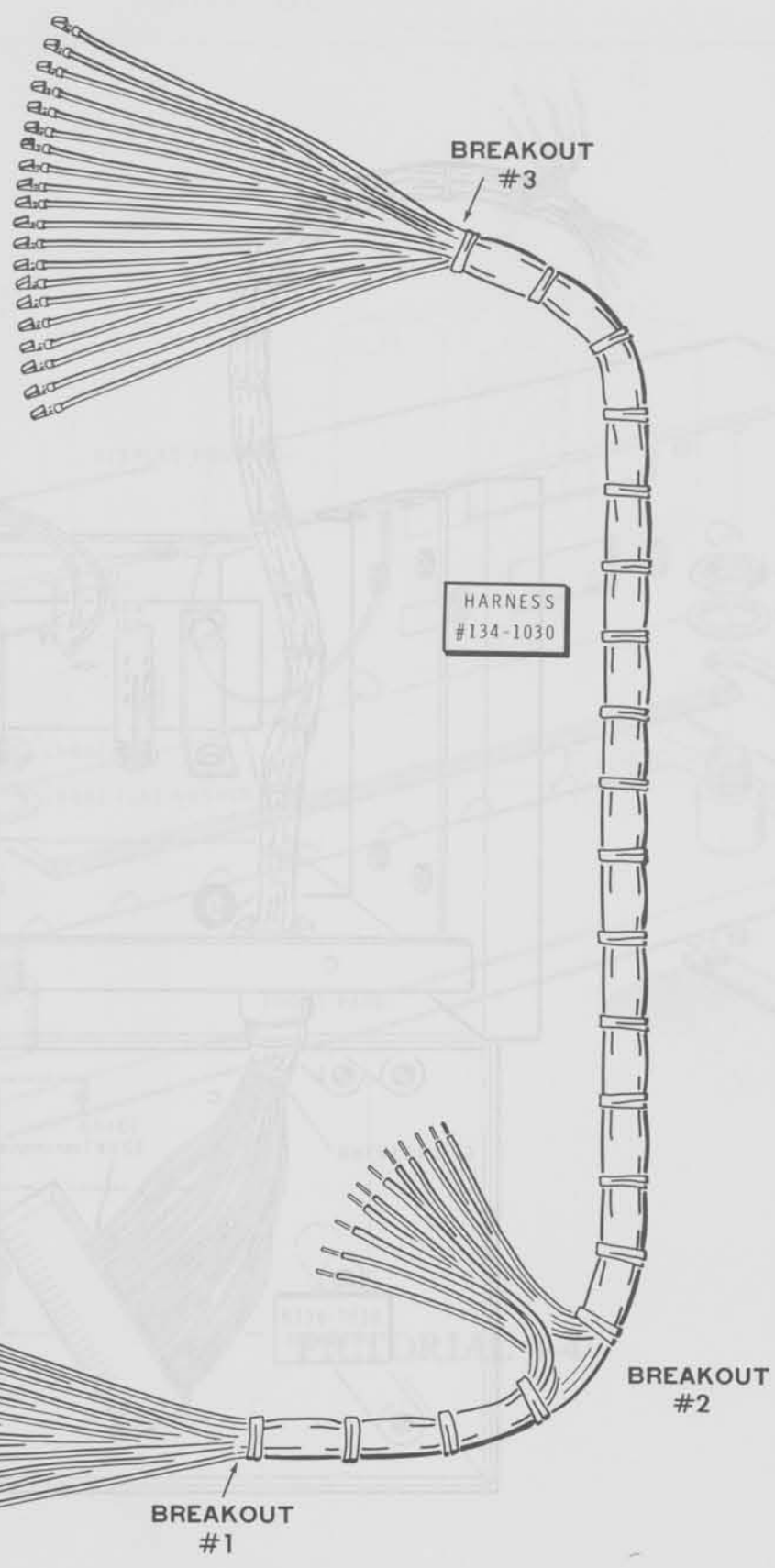
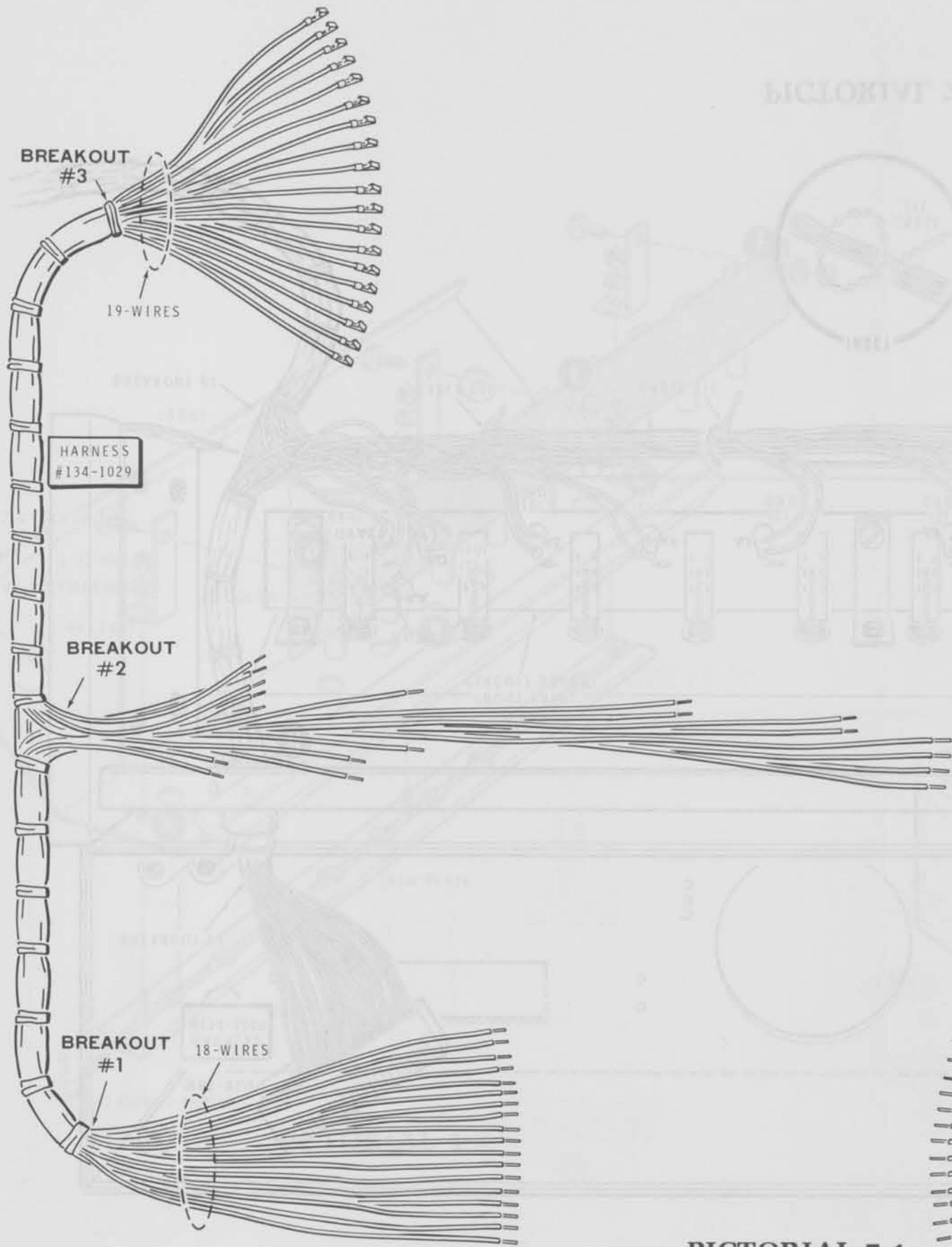

PICTORIAL 7-1

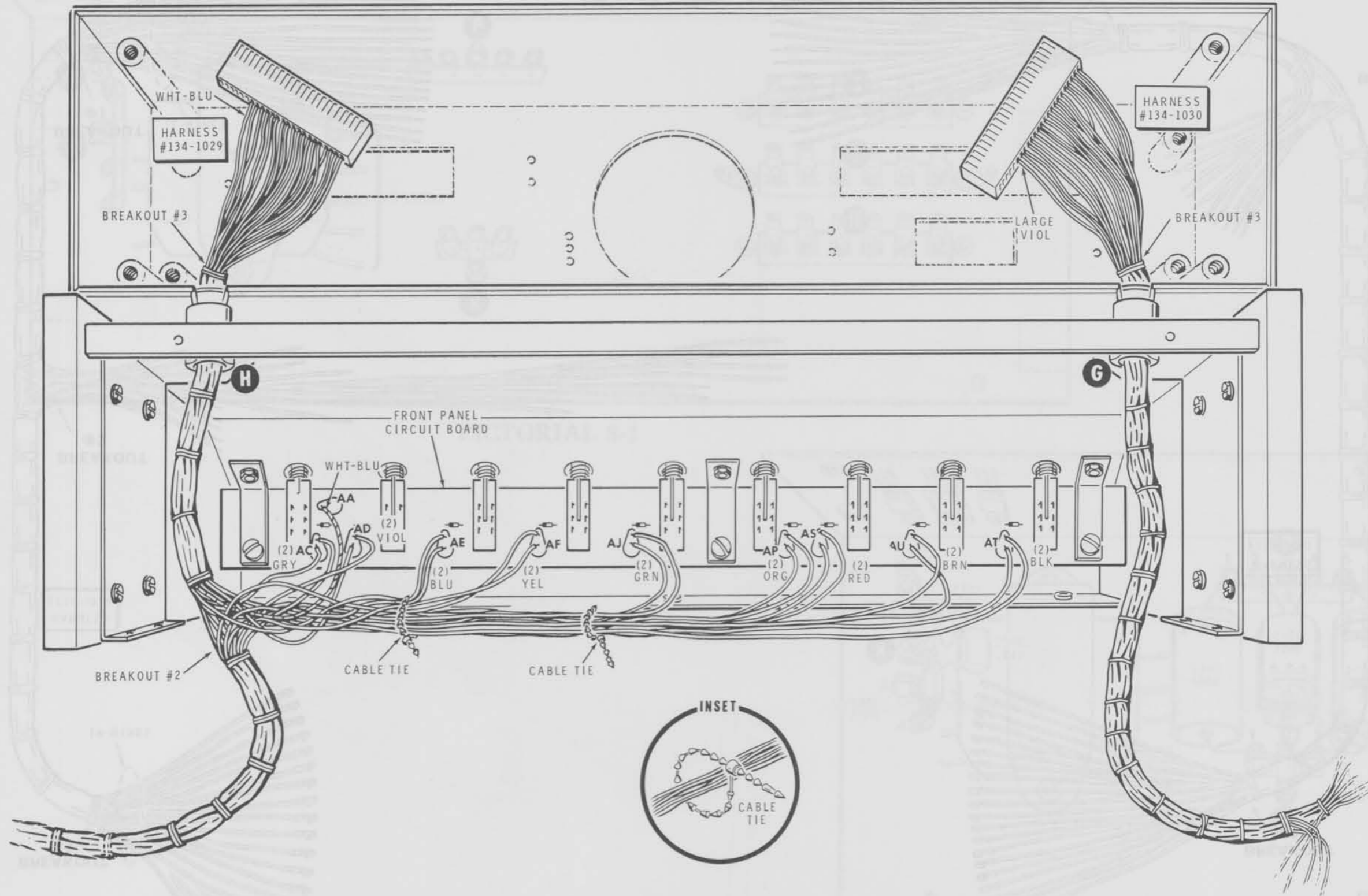

PICTORIAL 7-2

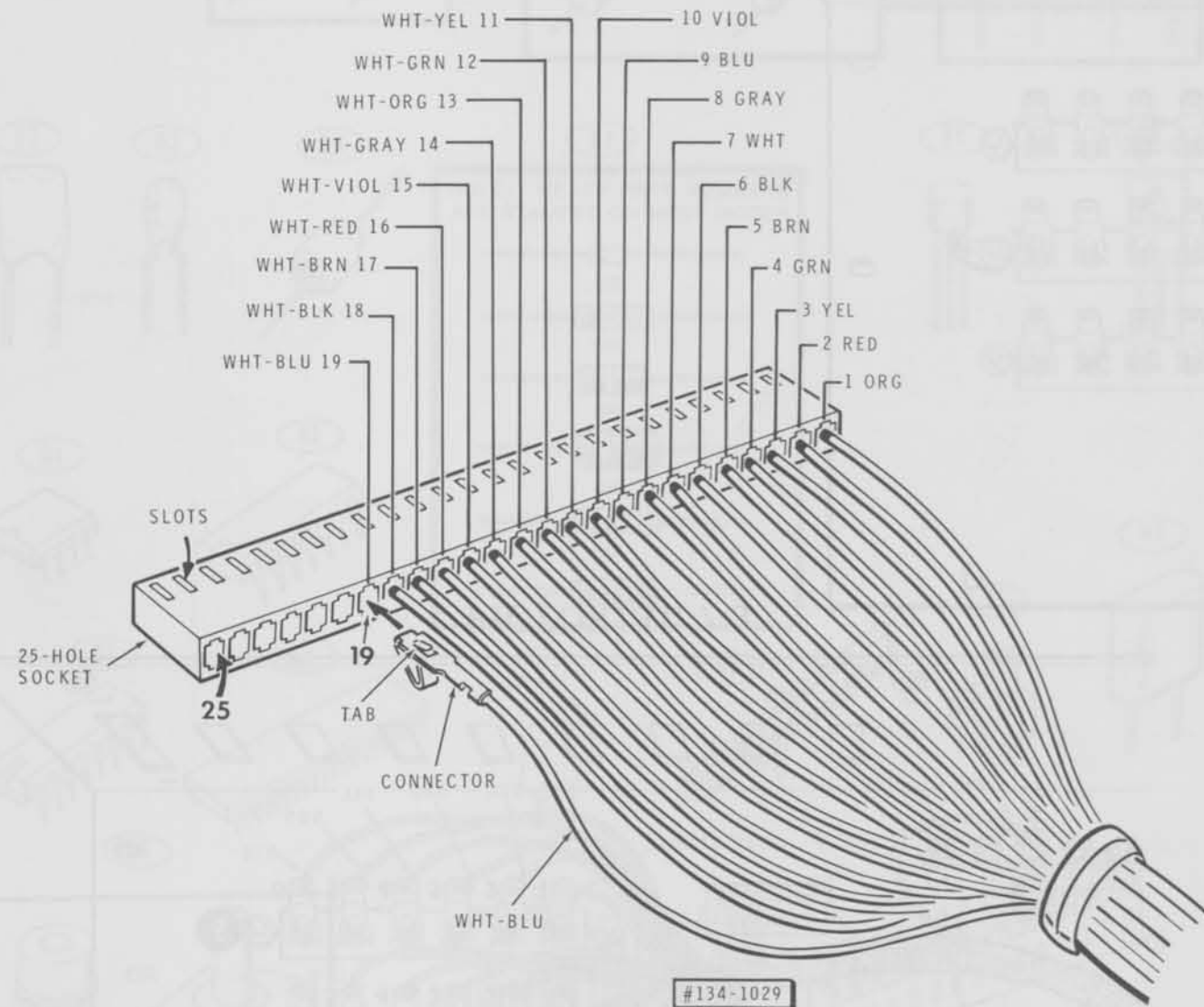

Detail 7-2A

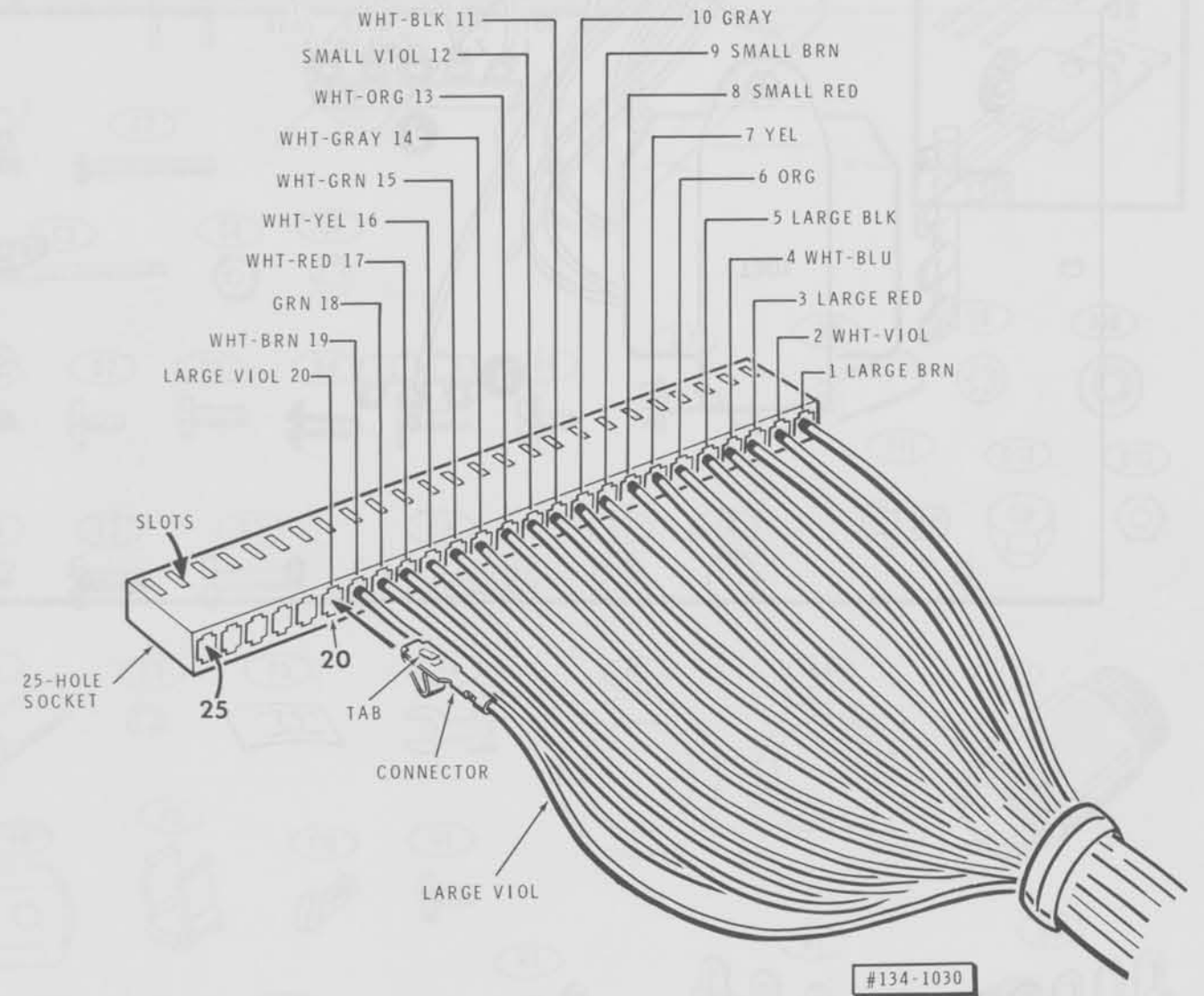

Detail 7-2B

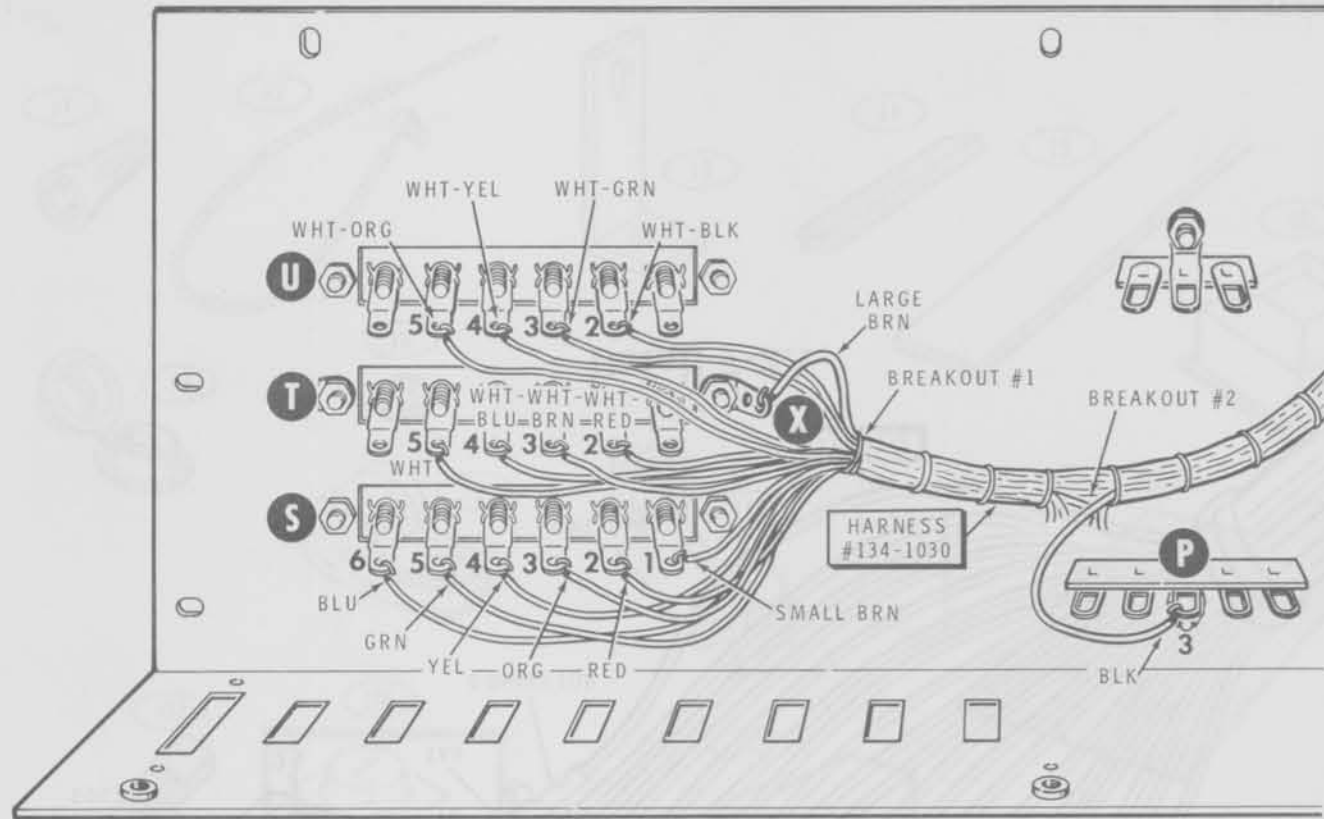

PICTORIAL 7-3

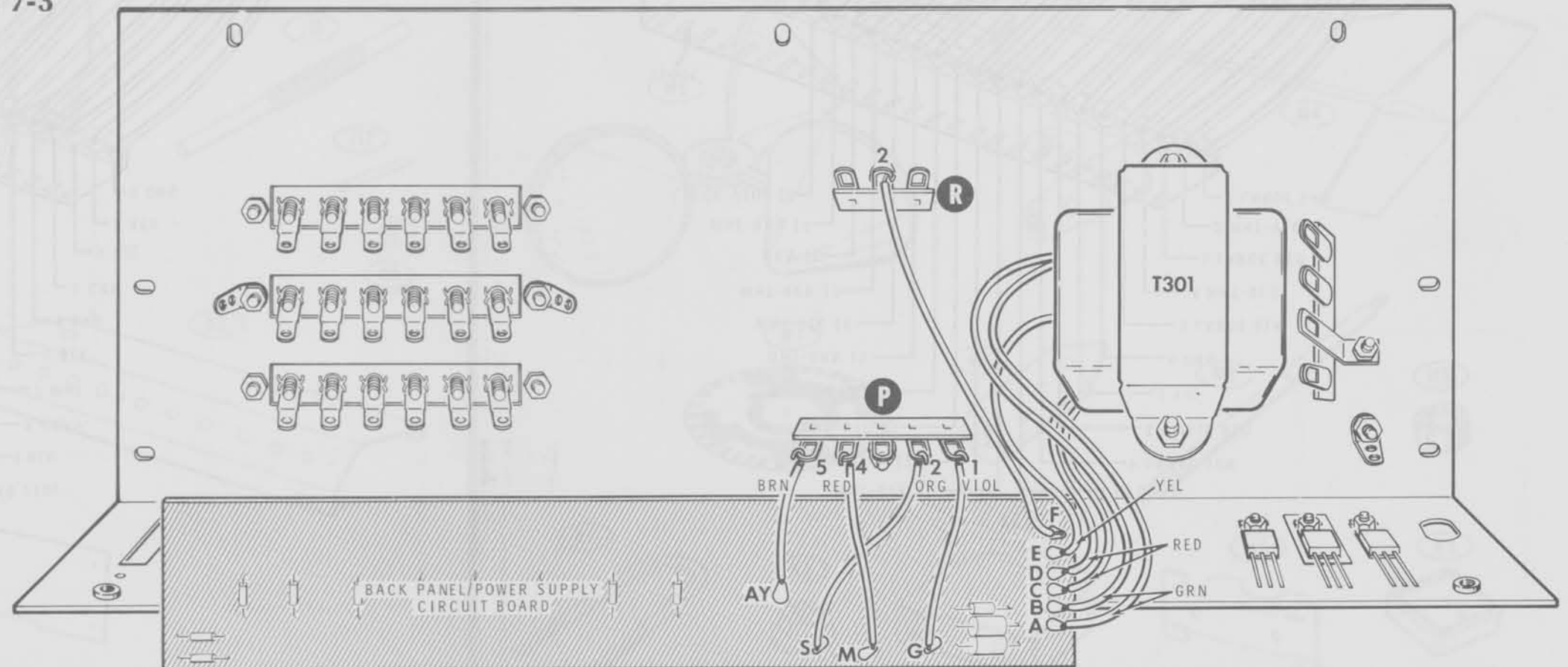

PICTORIAL 7-4

PARTS PICTORIAL

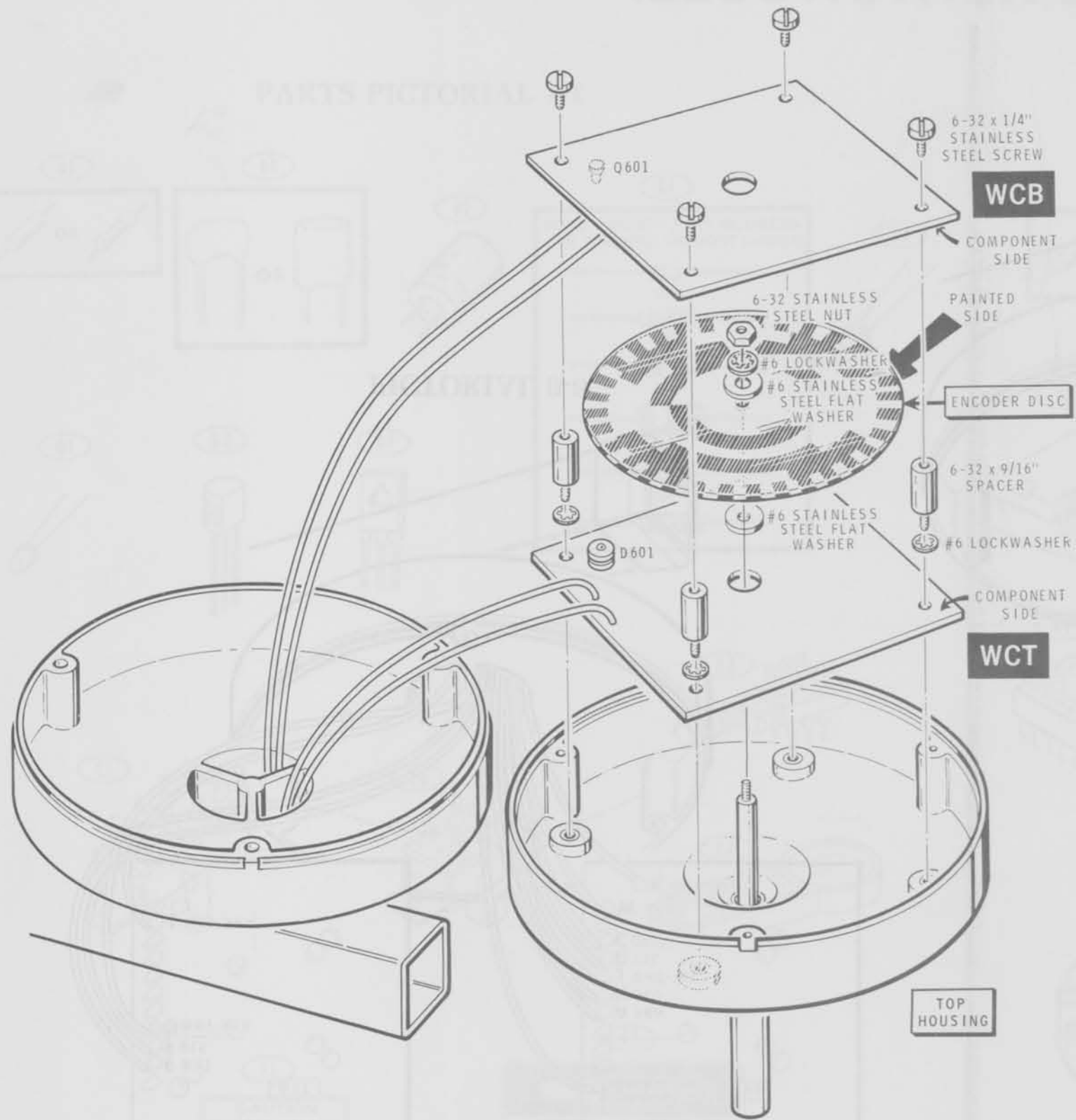

PICTORIAL 9-6

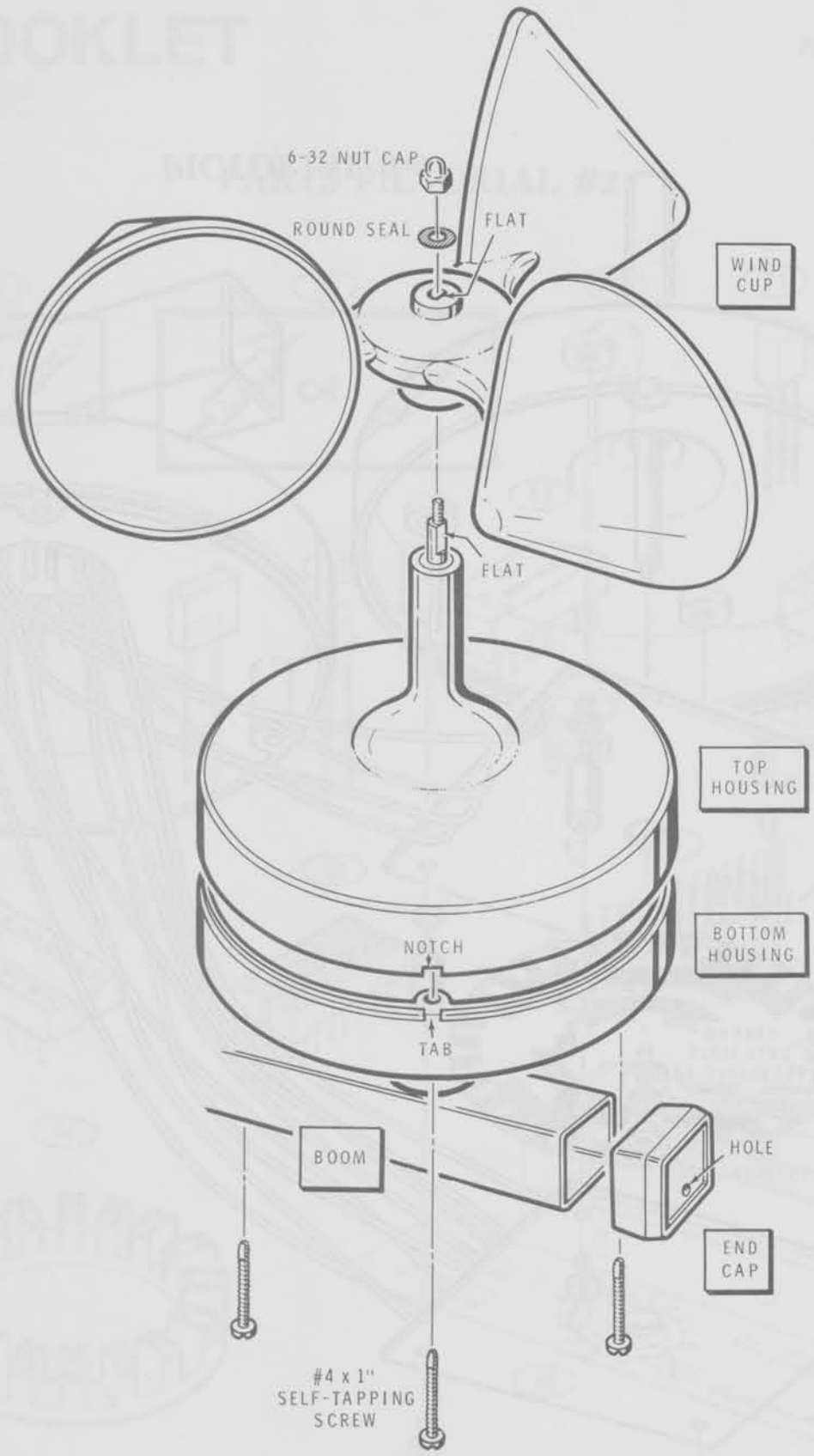

PICTORIAL 9-7

