

PRICE \$2.00

HEATH COMPANY BENTON HARBOR, MICHIGAN

# HEATHKIT® ASSEMBLY MANUAL

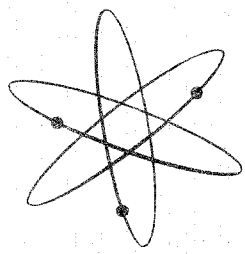











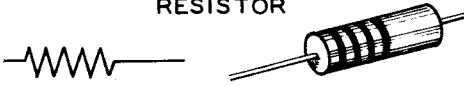
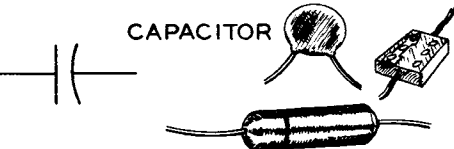
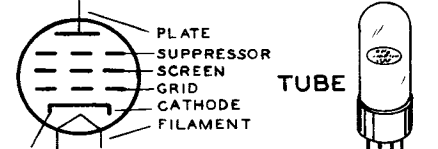
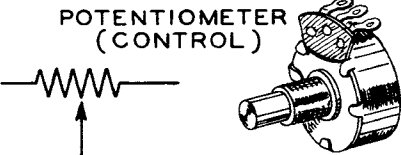
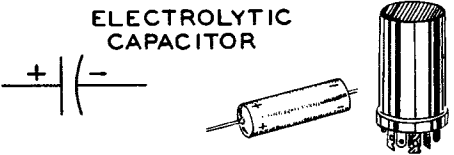
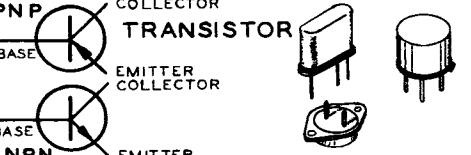
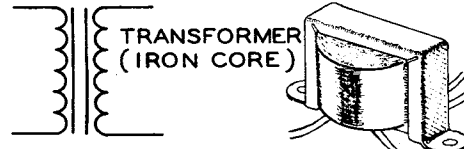
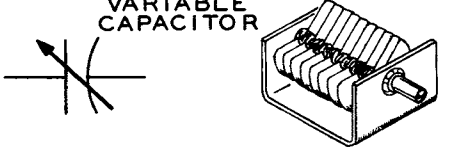
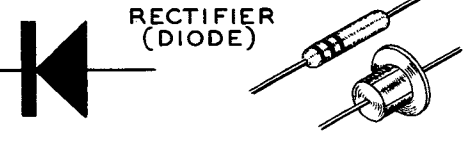
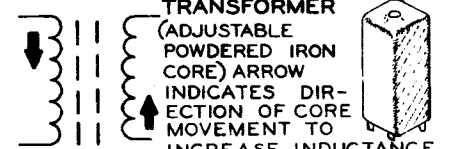
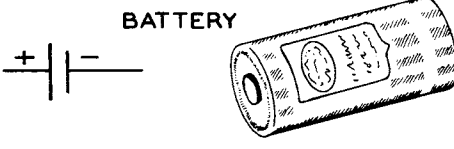
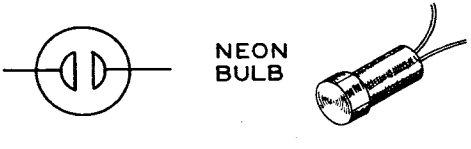
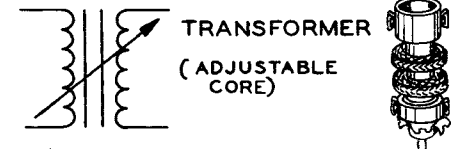
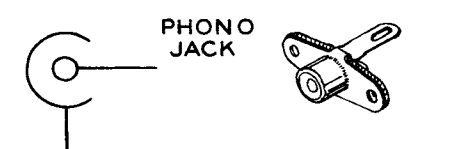
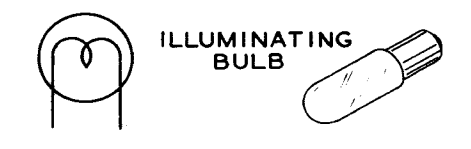
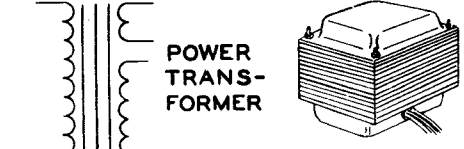

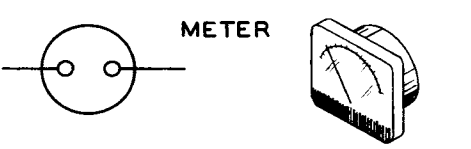
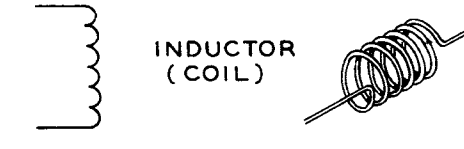
## SSB TRANSCEIVER

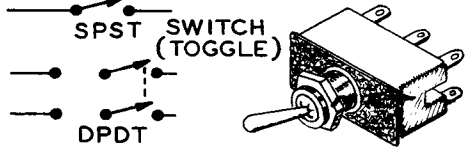
MODEL SB-101

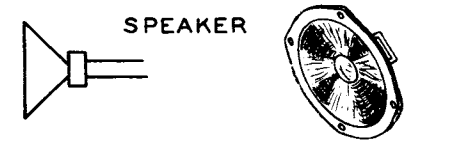
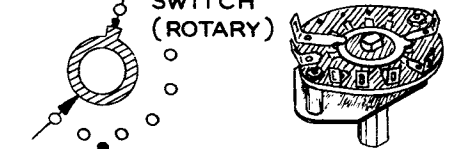
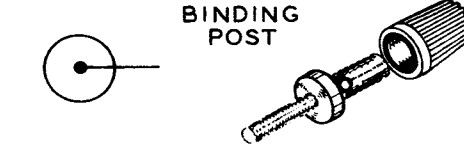
## TYPICAL COMPONENT TYPES

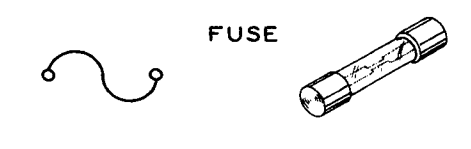
This chart is a guide to commonly used types of electronic components. The symbols and related illustrations

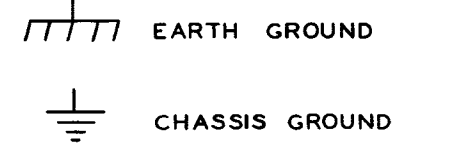
should prove helpful in identifying most parts and reading the schematic diagrams.

<p style="text-align: center;"><b>RESISTOR</b></p> 	<p style="text-align: center;"><b>CAPACITOR</b></p> 	<p style="text-align: center;"><b>TUBE</b></p> 
<p style="text-align: center;"><b>POTENTIOMETER (CONTROL)</b></p> 	<p style="text-align: center;"><b>ELECTROLYTIC CAPACITOR</b></p> 	<p style="text-align: center;"><b>TRANSISTOR</b></p> 
<p style="text-align: center;"><b>TRANSFORMER (IRON CORE)</b></p> 	<p style="text-align: center;"><b>VARIABLE CAPACITOR</b></p> 	<p style="text-align: center;"><b>RECTIFIER (DIODE)</b></p> 
<p style="text-align: center;"><b>TRANSFORMER (ADJUSTABLE POWDERED IRON CORE) ARROW INDICATES DIRECTION OF CORE MOVEMENT TO INCREASE INDUCTANCE</b></p> 	<p style="text-align: center;"><b>BATTERY</b></p> 	<p style="text-align: center;"><b>NEON BULB</b></p> 
<p style="text-align: center;"><b>TRANSFORMER (ADJUSTABLE CORE)</b></p> 	<p style="text-align: center;"><b>PHONO JACK</b></p> 	<p style="text-align: center;"><b>ILLUMINATING BULB</b></p> 
<p style="text-align: center;"><b>POWER TRANSFORMER</b></p> 	<p style="text-align: center;"><b>PHONE JACK</b></p> 	<p style="text-align: center;"><b>METER</b></p> 
<p style="text-align: center;"><b>INDUCTOR (COIL)</b></p> 	<p style="text-align: center;"><b>RECEPTACLE</b></p> 	<p style="text-align: center;"><b>SPST SWITCH (TOGGLE)</b> <b>DPDT</b></p> 
<p style="text-align: center;"><b>PIEZOELECTRIC CRYSTAL</b></p> 	<p style="text-align: center;"><b>SPEAKER</b></p> 	<p style="text-align: center;"><b>SWITCH (ROTARY)</b></p> 
<p style="text-align: center;"><b>BINDING POST</b></p> 	<p style="text-align: center;"><b>MICROPHONE</b></p> 	<p style="text-align: center;"><b>FUSE</b></p> 
<p style="text-align: center;"><b>ANTENNA</b> GENERAL      LOOP</p> 	<p style="text-align: center;"><b>EARTH GROUND</b> <b>CHASSIS GROUND</b></p> 	<p style="text-align: center;"><b>CONDUCTORS</b> NOT CONNECTED      CONNECTED      SHIELDED</p> 

Assembly  
and  
Operation  
of the



# SSB TRANSCEIVER

Model SB-101



HEATH COMPANY  
BENTON HARBOR,  
MICHIGAN

## TABLE OF CONTENTS

Introduction. . . . .	2
Circuit Board Parts List. . . . .	3
Circuit Board Assembly. . . . .	5
Chassis Parts List. . . . .	22
Chassis Assembly	
Parts Mounting. . . . .	26
Harness Wiring. . . . .	36
Coaxial Cable Harness Wiring. . . . .	42
Component Mounting-Chassis Bottom. . . . .	44
Wiring RF Section-Chassis Top. . . . .	50
Dial Mounting. . . . .	51
Mounting Parts-Front Panel. . . . .	55
Front Panel Wiring. . . . .	56
Front Panel Mounting. . . . .	60
Wiring-Chassis Top. . . . .	62
Final Wiring-Chassis Bottom. . . . .	70
Control Functions. . . . .	80
Preliminary Checks. . . . .	82
Power Supply Connections. . . . .	90
Initial Test. . . . .	92
Alignment. . . . .	93
Special Crystal Considerations. . . . .	98
Cabinet Installation. . . . .	100
Installation. . . . .	102
Noise Suppression Troubleshooting Chart. . . . .	107
Operation. . . . .	108
In Case Of Difficulty. . . . .	112
Troubleshooting Chart. . . . .	113
Specifications. . . . .	121
Circuit Description. . . . .	125
Chassis Photos. . . . .	146
Circuit Board X-Ray Views. . . . .	148
Schematic. . . . . (fold-out from page). . . . .	151
Replacement Parts Price List. . . . .	152

## INTRODUCTION

The Heathkit Model SB-101 Transceiver is a compact 80 through 10 meter transmitter and receiver. It is capable of SSB (single sideband with suppressed carrier) and CW (keyed continuous wave) operation. It may also be used as an exciter for a linear amplifier. Heathkit DC and AC power supplies are available for use with this Transceiver to provide both mobile and fixed-station operation.

Provisions are made for both VOX (voice-operated-transmit) and PTT (push-to-talk) operation. An anti-trip circuit prevents the received signal, at the speaker, from switching the transmitter on during VOX operation. The pre-assembled, prealigned, linear master oscillator (LMO) and the crystal-controlled heterodyne oscillator assure accurate, stable operation with easy alignment.

The large tuning knob, and the smooth operation of the dial mechanism, provide convenient,

backlash-free tuning. A built-in crystal calibrator allows the dial to be accurately calibrated at 100 kHz\* intervals. Other features include: TALC\*\* (triple action level control) to prevent overdriving the final amplifiers; tone-actuated CW operation; and an S-meter that is switch-controlled in the transmit mode of operation to measure Grid Current, Plate Current, ALC Voltage, Relative Power, and High Voltage. A total of twenty tubes and sixteen diodes are used.

The use of circuit boards, Switch-Boards\*\*, and wiring harnesses provide a clean, compact chassis layout and greatly simplifies kit assembly.

**NOTE:** Refer to the "Kit Builders Guide" for complete information on unpacking, parts identification, tools, wiring, soldering, and step-by-step assembly procedures.

\*NOTE: This Manual uses the new IEEE (Institute of Electrical and Electronic Engineers) and international standard term "hertz" as the basic unit of frequency. The terms are used as follows:

Hz (hertz) = cps (cycles per second).

kHz (kilohertz) = kc (kilocycles per second).

MHz (megahertz) = mc (megacycles per second).

\*\*Registered Trademark, Heath Company.

## CIRCUIT BOARD PARTS LIST

NOTE: This Parts List contains only the parts that will be used in the assembly of the circuit boards. The Chassis Parts are listed separately after the circuit boards are assembled.

Do not open the small envelopes with part numbers on them until those parts are called for in steps.

To avoid intermixing the parts, do not open any packages at this time, except the one listed below.

Unpack package #1, then check each part against the following Parts List. The numbers in parentheses correspond to the numbers in the parts pictorials.

PART No.	PARTS Per Kit	DESCRIPTION
-------------	------------------	-------------

### RESISTORS

#### 1/2 Watt

(1) 1-83	2	56 $\Omega$ (green-blue-black)
1-3	4	100 $\Omega$ (brown-black-brown)
1-111	2	150 $\Omega$ (brown-green-brown)
1-45	5	220 $\Omega$ (red-red-brown)
1-4	7	330 $\Omega$ (orange-orange-brown)
1-6	3	470 $\Omega$ (yellow-violet-brown)
1-9	8	1000 $\Omega$ (brown-black-red)
1-90	3	2000 $\Omega$ (red-black-red)
1-14	1	3300 $\Omega$ (orange-orange-red)
1-16	7	4700 $\Omega$ (yellow-violet-red)
1-20	2	10 K $\Omega$ (brown-black-orange)
1-22	6	22 K $\Omega$ (red-red-orange)
1-24	2	33 K $\Omega$ (orange-orange-orange)
1-25	10	47 K $\Omega$ (yellow-violet-orange)
1-26	21	100 K $\Omega$ (brown-black-yellow)
1-27	4	150 K $\Omega$ (brown-green-yellow)
1-29	2	220 K $\Omega$ (red-red-yellow)
1-31	3	330 K $\Omega$ (orange-orange-yellow)

PART No.	PARTS Per Kit	DESCRIPTION
-------------	------------------	-------------

### Resistors (cont'd.)

1-33	8	470 K $\Omega$ (yellow-violet-yellow)
1-34	2	680 K $\Omega$ (blue-gray-yellow)
1-35	8	1 megohm (brown-black-green)
1-36	1	1.5 megohm (brown-green-green)
1-37	1	2.2 megohm (red-red-green)
1-38	2	3.3 megohm (orange-orange-green)
1-40	1	10 megohm (brown-black-blue)
<b>1 Watt</b>		
(2) 1-3-1	1	3300 $\Omega$ (orange-orange-red)
1-5-1	1	22 K $\Omega$ (red-red-orange)
<b>7 Watt</b>		
(3) 3-15-7	1	1000 $\Omega$
3-16-7	1	2500 $\Omega$



<u>PART No.</u>	<u>PARTS Per Kit</u>	<u>DESCRIPTION</u>	<u>PART No.</u>	<u>PARTS Per Kit</u>	<u>DESCRIPTION</u>
<b>CAPACITORS</b>			<b>TRANSFORMERS</b>		
<b>Mica</b>			(19) 52-65	1	8.4-8.9 MHz bandpass
(4) 20-130	3	12 pf	52-73	1	3.395 MHz IF
20-77	4	24 pf	52-79	3	3.395 MHz
20-96	3	36 pf	<b>DIODES</b>		
20-97	6	50 pf	(20) 56-25	1	Zener, 15 V, 1 W (1N4166A)
20-102	6	100 pf	(21) 56-26-1	5	1N191 germanium (brown-white-brown)
20-105	3	180 pf	(22) 57-27	5	Silicon 750 ma 500 PIV
20-107	2	680 pf	<b>CONTROLS</b>		
<b>Disc</b>			(23) 10-147	2	200 $\Omega$
(5) 21-78	1	5 pf	10-149	1	500 K $\Omega$
21-13	4	500 pf	<b>SWITCHES</b>		
21-14	7	.001 $\mu$ fd	(24) 63-396	2	Rotary wafer (red color dot)
21-27	21	.005 $\mu$ fd	63-397	2	Rotary wafer (yellow color dot)
21-16	6	.01 $\mu$ fd	<b>CRYSTALS</b>		
21-31	44	.02 $\mu$ fd	(25) 404-43	1	100 kHz
<b>Other Capacitors</b>			404-205	1	3393.6 kHz
(6) 25-115	2	10 $\mu$ fd electrolytic	404-215	1	3395.4 kHz
(7) 25-135	2	20 $\mu$ fd tubular electrolytic	404-206	1	3396.4 kHz
(8) 26-94	1	13 pf differential	404-207	1	12.395 MHz
(9) 26-122	1	2-section variable	404-208	1	15.895 MHz
(10) 27-34	5	.2 $\mu$ fd resin	404-209	1	22.895 MHz
(11) 27-19	1	1 $\mu$ fd tubular	404-210	1	29.895 MHz
(12) 31-36	2	8-50 pf trimmer	404-211	1	36.895 MHz
<b>COILS</b>			404-212	1	37.395 MHz
(13) 40-484	1	36 $\mu$ h (orange-blue)	404-213	1	37.895 MHz
40-487	1	300 $\mu$ h (orange-black-brown)	404-214	1	38.395 MHz
(14) 40-587	1	6.8 MHz trap			
(15) 40-686	2	7 MHz (yellow color dot)			
(16) 40-687	4	14/21 MHz (green color dot)			
40-693	1	28 MHz (brown color dot)			
40-688	2	29 MHz (black color dot)			
40-692	1	29.5 MHz (blue color dot)			
(17) 40-685	2	3.5 MHz (gray color dot)			
(18) 40-689	1	3.5/7 MHz (red color dot)			
40-690	1	14/21 MHz (orange color dot)			
40-691	1	28.5/29 MHz (violet color dot)			

<u>PART No.</u>	<u>PARTS Per Kit</u>	<u>DESCRIPTION</u>	<u>PART No.</u>	<u>PARTS Per Kit</u>	<u>DESCRIPTION</u>
<b>CIRCUIT BOARDS</b>			<b>MISCELLANEOUS</b>		
85-127-1	1	Modulator	(26) 45-51	2	15 $\mu$ h choke
85-128-2	1	IF	(27) 84-22	1	P.E.C. (printed electronic circuit)
85-129-2	1	Bandpass	(28) 250-133	1	3-48 x 7/16" screw
85-130-1	1	Audio	(29) 252-1	1	3-48 nut
85-131-2	1	RF-driver	(30) 254-7	1	#3 lockwasher
85-132-1	1	Crystal	344-50	1	Black hookup wire
85-133-1	1	Heterodyne oscillator	346-1	1	Small sleeving
85-133-2	1	Driver grid	(31) 434-74	1	Crystal socket
85-133-3	1	Driver plate	(32) 434-129	7	7-pin tube socket
			434-130	10	9-pin tube socket
			490-5	1	Nut starter (Refer to Page 3 of the Kit Builders Guide)
			331-6		Solder
			595-840	1	Manual
			597-308	1	Kit Builders Guide
			597-260	1	Parts order envelope
			391-34	1	Identification label
			597-367	1	Registration card

## CIRCUIT BOARD ASSEMBLY

Before starting to assemble this kit, read the Kit Builders Guide for complete information on wiring, soldering, and step-by-step assembly procedures.

Use 1/2 watt resistors unless directed otherwise in a step. All resistors will be called out by only the resistance value (in  $\Omega$ ,  $K\Omega$ , or megohm) and color code. Capacitors will be called out only by the capacitance value and type.

Be especially careful not to cover unused holes, or to bridge solder between foils, during the assembly of the circuit boards.

In some instances, resistors will be mounted vertically. Position all parts as shown in the Pictorials. Follow the instructions carefully, and read the entire step before performing the operation.

Locate each circuit board by its part number, which will be listed in the upper left-hand corner of the page. Position the boards lettered side up as shown in the Pictorials.

When a circuit board is finished, set it aside until it is called for later in the assembly instructions.

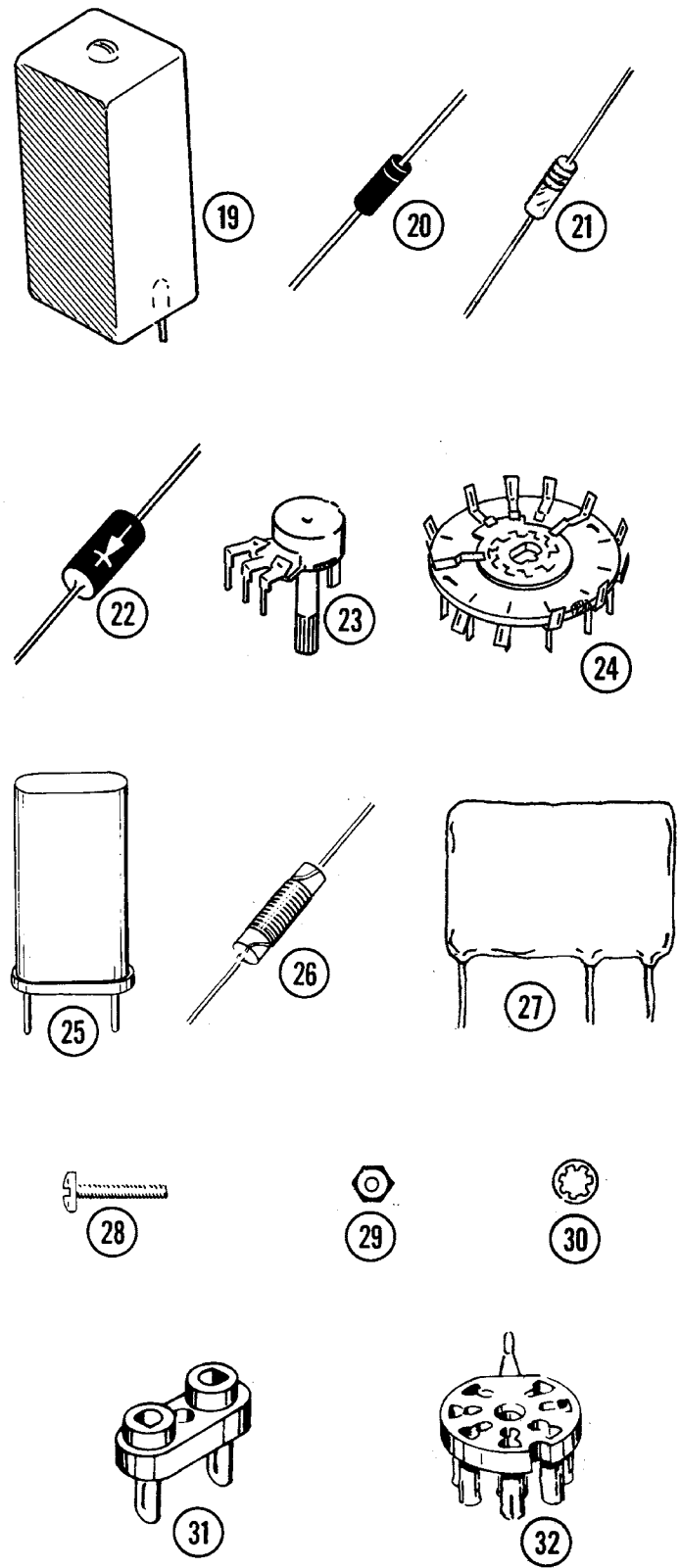
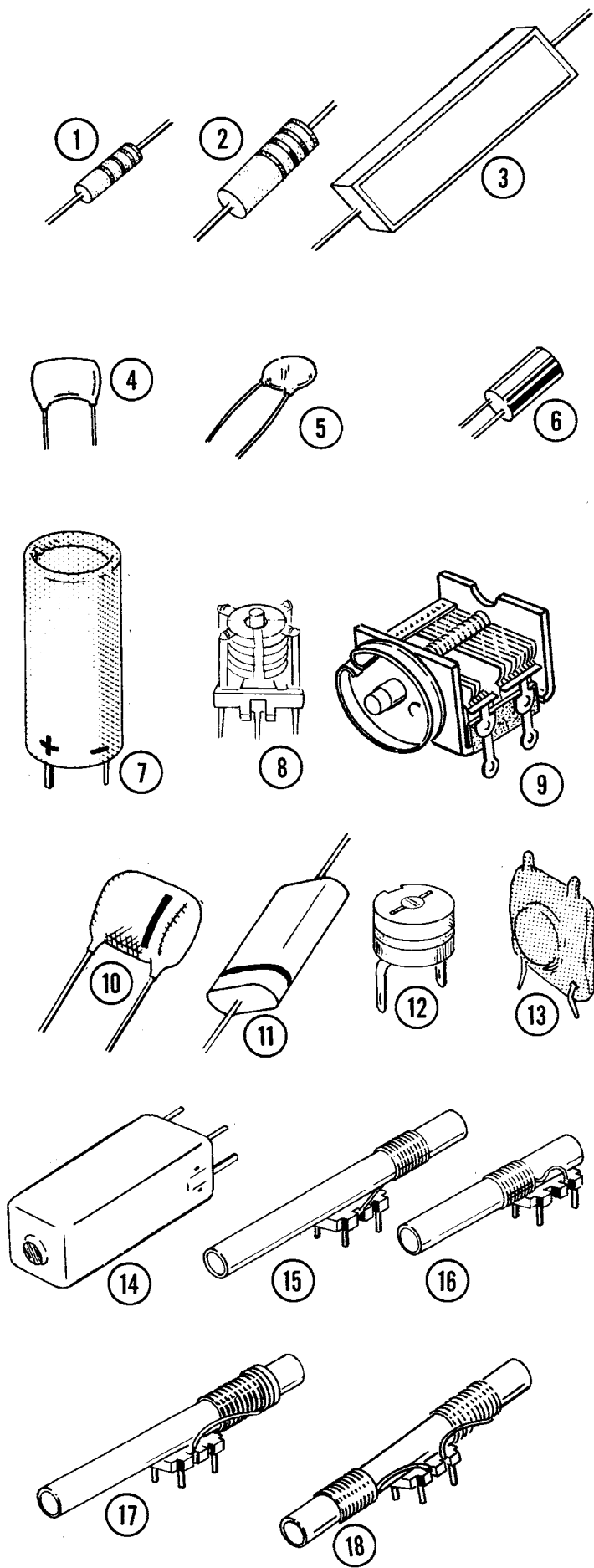



# START



Crystal Circuit Board #85-132-1

NOTE: Solder the pins of each part as it is installed. Do not cut off the crystal or switch pins after soldering.

( ) 12.395 MHz crystal (#404-207).

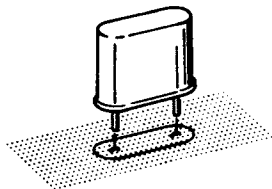

( ) 22.895 MHz crystal (#404-209).

( ) 15.895 MHz crystal (#404-208).

( ) 36.895 MHz crystal (#404-211).

( ) 29.895 MHz crystal (#404-210).

( ) 37.395 MHz crystal (#404-212).

( ) 37.895 MHz crystal (#404-213).

( ) 38.395 MHz crystal (#404-214).

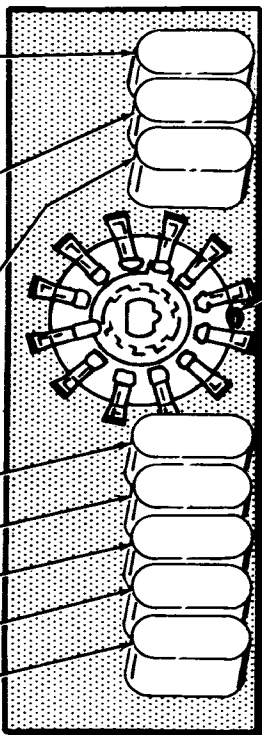

# CONTINUE



( ) Rotary switch wafer, #63-397 (yellow color dot). Position the color dot of the switch wafer over the color dot on the circuit board.

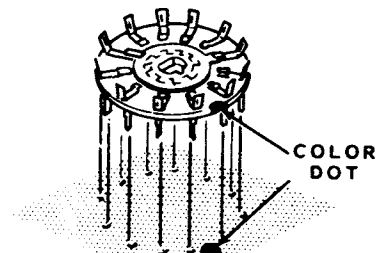

( ) Check to see that all connections are soldered.

# FINISH

PROCEED TO PICTORIAL 1-2

PICTORIAL 1-1

**START**



**CONTINUE**



Heterodyne Oscillator Circuit Board  
#85-133-1

NOTE: Solder the pins of the coils and switch wafer as they are installed, but do not cut off their pins after soldering.

( ) 100  $\Omega$  (brown-black-brown).

( ) .001  $\mu$ fd disc.

( ) Coil #40-693 (brown color dot). Position the color dot on the coil over the color dot on the circuit board. Hold the coil base firmly against the circuit board when soldering.

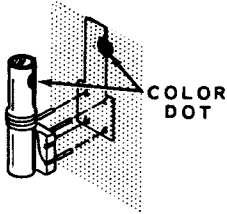

( ) Coil #40-692 (blue color dot).

( ) 100 pf mica.

( ) 50 pf mica

( ) 24 pf mica.

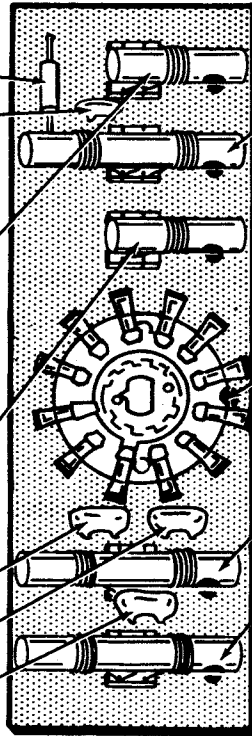

( ) Coil #40-691 (violet color dot). Hold the coil base firmly against the circuit board when soldering.

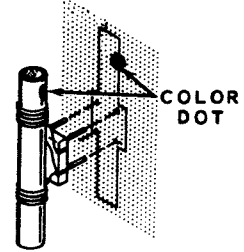

( ) Rotary switch wafer, #63-397 (yellow color dot). Position the color dot on the switch wafer over the color dot on the circuit board.

( ) Coil #40-689 (red color dot).

( ) Coil #40-690 (orange color dot).

( ) Check to see that all connections are soldered and cut off only the leads of the resistor and capacitors. Disregard any unused holes in the circuit board.

**FINISH**

PROCEED TO PICTORIAL 1-3

PICTORIAL 1-2

**START**



**Driver Grid Circuit Board**  
#85-133-2

**NOTE:** Align the coil forms with the outline on the circuit board. Then solder the pins of the coils and switch wafer as they are installed, but do not cut off their pins after soldering.

- ( ) 1000  $\Omega$  (brown-black-red).
- ( ) 680 pf mica.
- ( ) .01  $\mu$ fd disc.
- ( ) 12 pf mica.
- ( ) 180 pf mica.
- ( ) 1" bare wire. Use black hookup wire with the insulation removed.
- ( ) 36 pf mica.

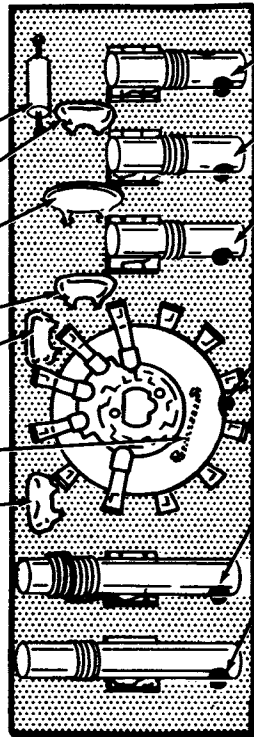

**PICTORIAL 1-3**

**CONTINUE**



- ( ) Coil #40-687 (green color dot).
- ( ) Coil #40-687 (green color dot).
- ( ) Coil #40-688 (black color dot).
- ( ) Rotary switch wafer, #63-396 (red color dot). Position the color dot on the switch wafer over the color dot on the circuit board.
- ( ) Coil #40-685 (gray color dot).
- ( ) Coil #40-686 (yellow color dot).
- ( ) Check to see that all connections are soldered, and cut off only the leads of the resistor, capacitors, and the bare wire. Disregard any unused holes in the circuit board.

**FINISH**

PROCEED TO PICTORIAL 1-4

**START**



**CONTINUE**



- Driver Plate Circuit Board**  
#85-133-3
- NOTE:** Solder the pins of the coils and switch wafer as they are installed, but do not cut off their pins after soldering.
- ( ) Choke #45-51.
  - ( ) 680 pf mica.
  - ( ) .01  $\mu$ fd disc.
  - ( ) 180 pf mica.
  - ( ) 1" bare wire. Use black hookup wire with the insulation removed.
  - ( ) 36 pf mica.

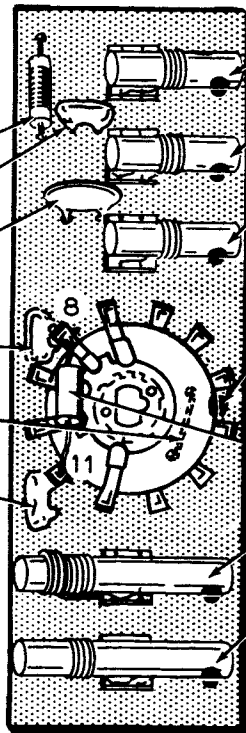

- ( ) Coil #40-687 (green color dot).
- ( ) Coil #40-687 (green color dot).
- ( ) Coil #40-688 (black color dot).
- ( ) Rotary switch wafer #63-396 (red color dot). Position the color dot of the switch wafer over the color dot on the circuit board.
- ( ) 22 K $\Omega$  (red-red-orange) between lugs 8 (S-1) and 11 (S-1) of switch wafer. Be sure the resistor clears the switch rotor. Cut off the excess leads.
- ( ) Coil #40-685 (gray color dot).
- ( ) Coil #40-686 (yellow color dot).
- ( ) Check to see that all connections are soldered, and cut off only the choke, capacitor, and bare wire leads. Disregard any unused holes in the circuit board.

**FINISH**

PROCEED TO PICTORIAL 1-5

PICTORIAL 1-4

**START**



**CONTINUE**



**Modulator Circuit Board #85-127-1**

NOTE: When installing silicon diodes, position the cathode end as shown. The cathode end may be marked by a color dot, color end, or color band.

CATHODE END

- ( ) Silicon diode (#57-27).
- ( ) Silicon diode (#57-27).
- ( ) 47 KΩ (yellow-violet-orange).
- ( ) 1 megohm (brown-black-green).
- ( ) 100 KΩ (brown-black-yellow).
- ( ) 1000 Ω (brown-black-red).
- ( ) 2000 Ω (red-black-red).
- ( ) 33 KΩ (orange-orange-orange).
- ( ) 100 KΩ (brown-black-yellow).
- ( ) 220 Ω (red-red-brown).
- ( ) 220 Ω (red-red-brown).
- ( ) 4700 Ω (yellow-violet-red).
- ( ) 2000 Ω (red-black-red).
- ( ) 4700 Ω (yellow-violet-red).

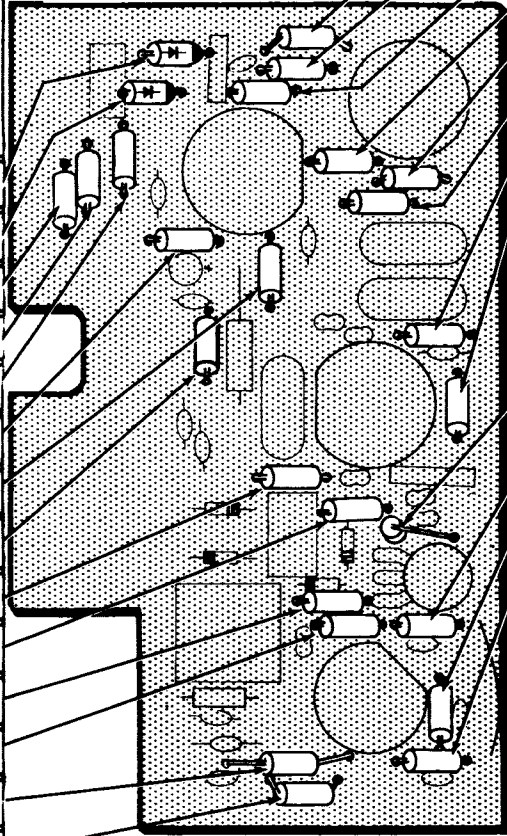

- ( ) 1 megohm (brown-black-green).
- ( ) 22 KΩ (red-red-orange).
- ( ) 150 KΩ (brown-green-yellow).
- ( ) 100 KΩ (brown-black-yellow).
- ( ) 4700 Ω (yellow-violet-red).
- ( ) 1 megohm (brown-black-green).
- ( ) 100 KΩ (brown-black-yellow).
- ( ) 33 KΩ (orange-orange-orange).
- ( ) 2000 Ω (red-black-red).

- ( ) 1 megohm (brown-black-green).
- ( ) 470 Ω (yellow-violet-brown).
- ( ) 47 KΩ (yellow-violet-orange).
- ( ) Check to see that all connections are soldered, and cut off the excess leads.

PROCEED TO PICTORIAL 1-6

PICTORIAL 1-5

**START**



**Modulator Circuit Board-Continued**

NOTE: When installing resin capacitors, position the banded end as shown.

( ) .2  $\mu$ fd resin. Note banded end,

( ) .2  $\mu$ fd resin. Position body to clear outline of tube socket V1. Note banded end.

( ) .01  $\mu$ fd disc.

NOTE: When installing electrolytic capacitors, position the positive (+) lead at the plus (+) mark on the circuit board.

( ) 10  $\mu$ fd electrolytic. Note (+) marking.

( ) .02  $\mu$ fd disc.

( ) .2  $\mu$ fd resin. Note banded end,

( ) .02  $\mu$ fd disc.

( ) .01  $\mu$ fd disc.

NOTE: When installing germanium diodes, position the banded end as shown.

( ) 1N191 germanium diode (brown-white-brown). Note banded end.

( ) 1N191 germanium diode (brown-white-brown). Note banded end.

( ) .02  $\mu$ fd disc.

( ) 5 pf disc.

( ) .01  $\mu$ fd disc.

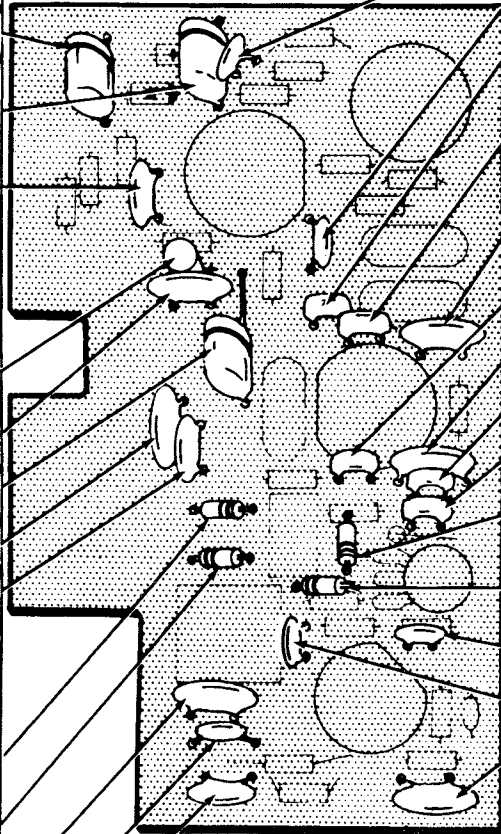

**CONTINUE**



( ) 500 pf disc.

( ) .001  $\mu$ fd disc.

( ) 12 pf mica.

( ) 24 pf mica. Position body to clear the outline of tube socket V16.

( ) .02  $\mu$ fd disc. Position body to clear the outline of tube socket V16.

( ) 36 pf mica.

( ) .02  $\mu$ fd disc.

( ) 50 pf mica.

( ) 100 pf mica.

( ) 1N191 germanium diode (brown-white-brown). Note banded end.

( ) 1N191 germanium diode (brown-white-brown). Note banded end.

( ) .005  $\mu$ fd disc.

( ) .005  $\mu$ fd disc.

( ) .02  $\mu$ fd disc.

( ) Check to see that all connections are soldered, and cut off the excess leads.

PROCEED TO PICTORIAL 1-7

PICTORIAL 1-6

**START**



**Modulator Circuit Board - continued**

- ( ) Solder the center pin to the ground clip on all the 7 and 9 pin tube sockets before mounting them on the circuit boards. Heat the center pin and allow the solder to flow onto the ground strap.

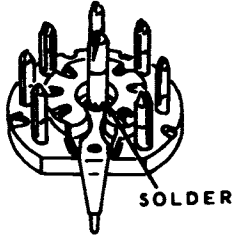

**NOTE:** Solder the connections of each part as it is installed. Do not cut off the lugs of any of these parts after soldering.

- ( ) Install 9-pin tube sockets at V1 and V16.

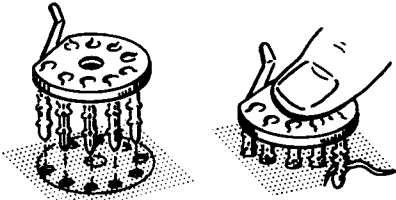

ALIGN ALL PINS WITH THEIR RESPECTIVE HOLES.

PRESS THE SOCKET DOWN UNTIL IT SNAPS IN PLACE.

- ( ) Install a 7-pin tube socket at V2.

- ( ) 13 pf differential capacitor (#26-94).

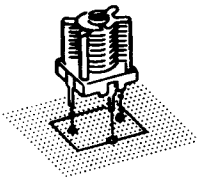

**CONTINUE**



- ( ) 20  $\mu$ fd electrolytic. Note (+) marking.
- ( ) 3393.6 kHz crystal (#404-205).
- ( ) 3395.4 kHz crystal (#404-215).
- ( ) 3396.4 kHz crystal (#404-206).

- ( ) 200  $\Omega$  control (#10-147).

LETTERED SIDE

SOLDER THE REAR OF THE CONTROL COVER TO THE FOIL.

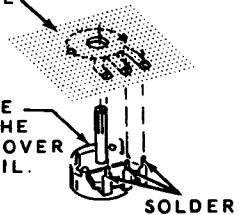

- ( ) 3,395 MHz transformer (#52-79).

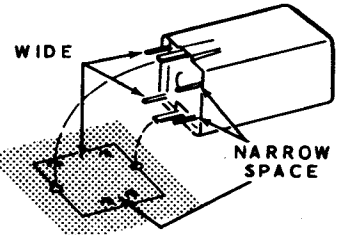

- ( ) Check to see that all connections are soldered. Do not cut off the lugs of any of these parts.

**FINISH**

PROCEED TO PICTORIAL 1-8

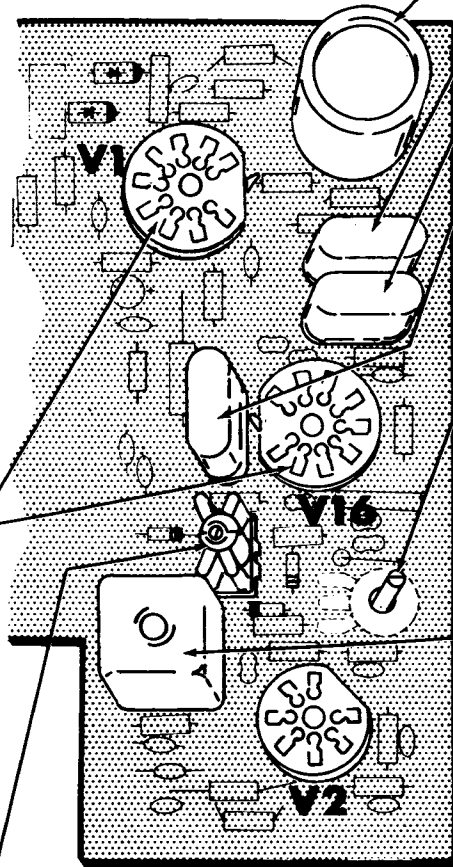

PICTORIAL 1-7

**START**

**CONTINUE**

- IF Circuit Board #85-128-2
- ( ) 1000 Ω (brown-black-red).
  - ( ) .005 μfd disc.
  - ( ) 22 KΩ 1 watt (red-red-orange).
  - ( ) .02 μfd disc.
  - ( ) .02 μfd disc.
  - ( ) 100 KΩ (brown-black-yellow).
  - ( ) 56 Ω (green-blue-black).
  - ( ) 56 Ω (green-blue-black).
  - ( ) 150 Ω (brown-green-brown).
  - ( ) 100 KΩ (brown-black-yellow).
  - ( ) 100 KΩ (brown-black-yellow).
  - ( ) 330 Ω (orange-orange-brown).

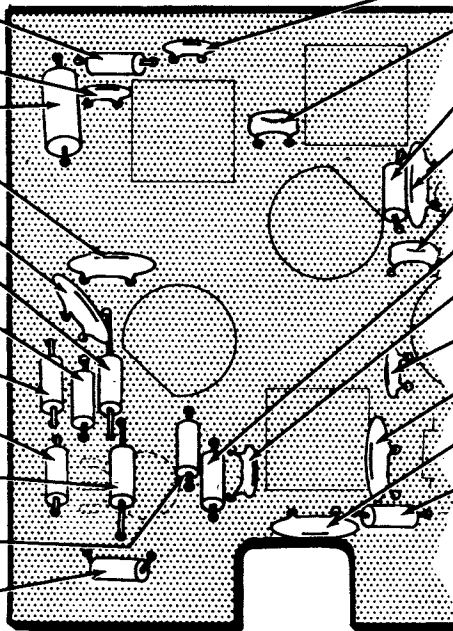

- ( ) .001 μfd disc.
- ( ) 50 pf mica.
- ( ) 220 Ω (red-red-brown).
- ( ) .02 μfd disc.
- ( ) 100 pf mica.
- ( ) 100 KΩ (brown-black-yellow).
- ( ) .005 μfd disc.
- ( ) 500 pf disc.
- ( ) .02 μfd disc.
- ( ) .02 μfd disc.
- ( ) 1000 Ω (brown-black-red).
- ( ) Check to see that all connections are soldered and cut off the excess leads.

PICTORIAL 1-8

PROCEED TO PICTORIAL 1-9

**START**

**CONTINUE**

- IF Circuit Board-Continued
- ( ) .02 μfd disc.
  - ( ) 1000 Ω (brown-black-red).
  - ( ) .02 μfd disc.
  - ( ) 10 megohm (brown-black-blue).
  - ( ) .02 μfd disc.
  - ( ) 47 KΩ (yellow-violet-orange).
  - ( ) 100 KΩ (brown-black-yellow).
  - ( ) 500 pf disc.
  - ( ) .02 μfd disc.

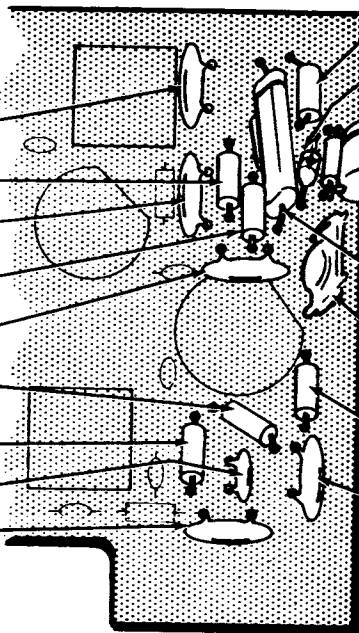

- ( ) 3300 Ω (orange-orange-red).
  - ( ) Silicon diode (#57-27).
  - ( ) 4700 Ω (yellow-violet-red) and .2 μfd resin combination. Note banded end of capacitor.
- .2 μfd

4700 Ω

SOLDER AND CUT OFF.

SOLDER AND CUT OFF.
- ( ) 1 μfd tubular. Note banded end.
  - ( ) 300 μH coil (orange-black-brown) #40-487.
  - ( ) 470 Ω (yellow-violet-brown).
  - ( ) .02 μfd disc.
  - ( ) Check to see that all connections are soldered, and cut off the excess leads.

PICTORIAL 1-9

**FINISH**

PROCEED TO PICTORIAL 1-10



**START**

IF Circuit Board-Continued
NOTE: Solder the connections of each part as it is installed. Do not cut off the lugs of these parts after soldering.
( ) Install 7-pin tube sockets at V3 and V4.
( ) Install a 9-pin tube socket at V13.
( ) 3,395 MHz IF transformer (#52-73). Note lug spacing.
( ) 6.8 MHz trap coil (#40-587). Disregard the red dot on the side of the coil.
( ) 3,395 MHz transformer (#52-79).
( ) 200 $\Omega$ control (#10-147). Mount the control from the foil side of the circuit board. Be sure to solder the tabs of the control cover to the foil.
( ) Check to see that all connections are soldered.

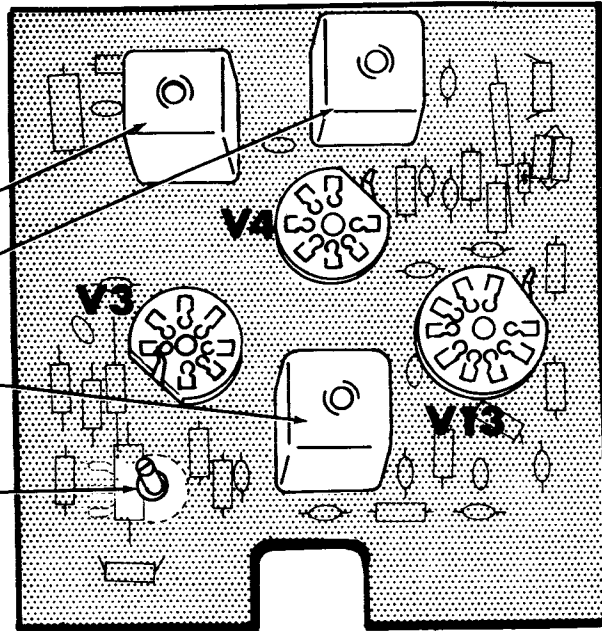
**FINISH**

PROCEED TO PICTORIAL 1-11

PICTORIAL 1-10

**START**



**CONTINUE**



- Bandpass Circuit Board #85-129-2
- ( ) 10 K $\Omega$  (brown-black-orange).
  - ( ) 220  $\Omega$  (red-red-brown).
  - ( ) 100 K $\Omega$  (brown-black-yellow).
  - ( ) 47 K $\Omega$  (yellow-violet-orange).
  - ( ) 330  $\Omega$  (orange-orange-brown).
  - ( ) 330  $\Omega$  (orange-orange-brown).
  - ( ) 2" wire. Use black hookup wire with 1/2" insulation removed from each end.
  - ( ) 100 K $\Omega$  (brown-black-yellow).
  - ( ) 470  $\Omega$  (yellow-violet-brown).
  - ( ) 330 K $\Omega$  (orange-orange-yellow).
  - ( ) 1000  $\Omega$  (brown-black-red).
  - ( ) 220 K $\Omega$  (red-red-yellow).
  - ( ) 100 K $\Omega$  (brown-black-yellow).
  - ( ) 1000  $\Omega$  (brown-black-red).

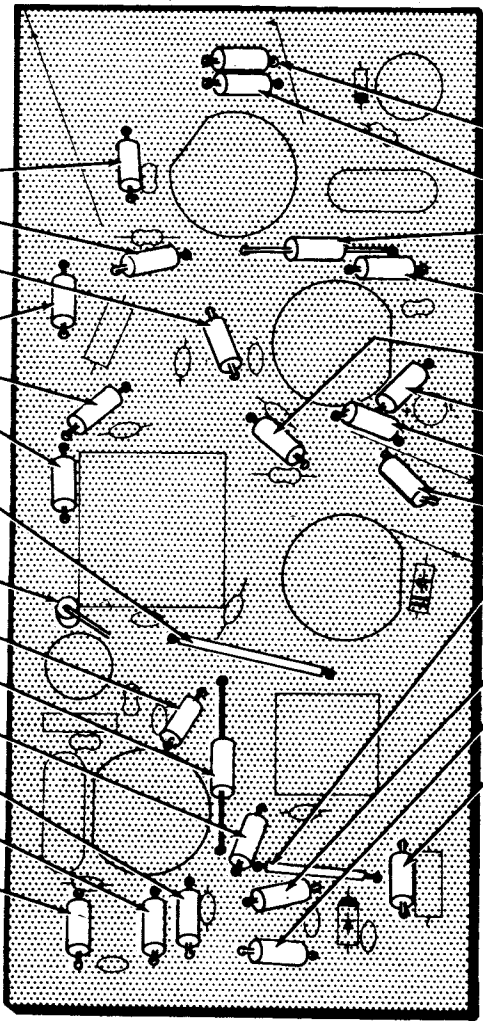

- ( ) 4700  $\Omega$  (yellow-violet-red).
- ( ) 100 K $\Omega$  (brown-black-yellow).
- ( ) 150 K $\Omega$  (brown-green-yellow).
- ( ) 1.5 megohm (brown-green-green)
- ( ) 470 K $\Omega$  (yellow-violet-yellow).
- ( ) 330  $\Omega$  (orange-orange-brown).
- ( ) 100 K $\Omega$  (brown-black-yellow).
- ( ) 100 K $\Omega$  (brown-black-yellow).
- ( ) 2" wire. Use black hookup wire with 1/2" of insulation removed from each end.
- ( ) 330  $\Omega$  (orange-orange-brown).
- ( ) 100  $\Omega$  (brown-black-brown).
- ( ) 470 K $\Omega$  (yellow-violet-yellow).
- ( ) Check to see that all connections are soldered, and cut off the excess leads.

PICTORIAL 1-11

PROCEED TO PICTORIAL 1-12

**START**



**Bandpass Circuit Board-Continued**

- ( ) 50 pf mica.
- ( ) 100 pf mica.
- ( ) 15  $\mu$ h choke (#45-51).
- ( ) .02  $\mu$ fd disc.
- ( ) .02  $\mu$ fd disc.
- ( ) .02  $\mu$ fd disc.
- ( ) .02  $\mu$ fd disc.
- ( ) .05  $\mu$ fd disc.
- ( ) 100 pf mica.
- ( ) 36  $\mu$ h coil #40-484 (orange-blue).
- ( ) 12 pf mica.
- ( ) .02  $\mu$ fd disc.
- ( ) .02  $\mu$ fd disc.
- ( ) .005  $\mu$ fd disc.

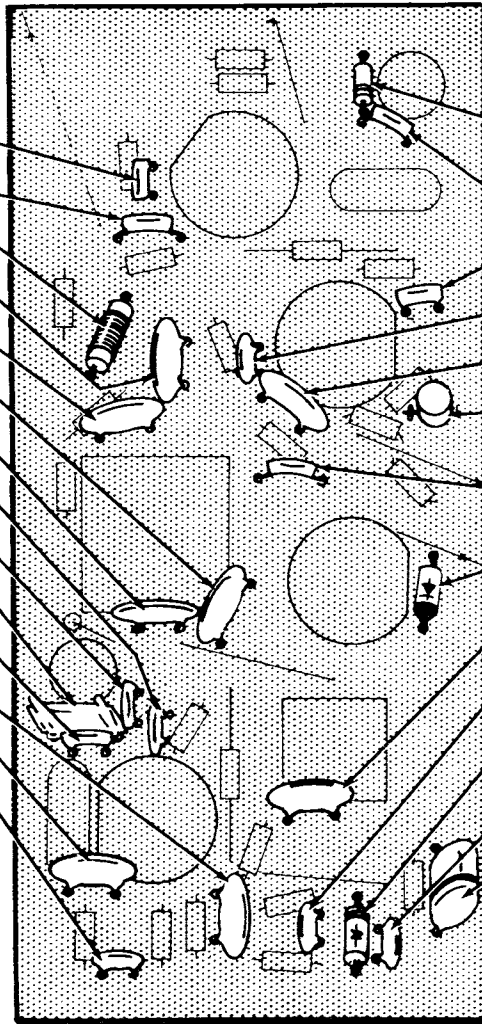

**CONTINUE**



- ( ) 1N191 germanium diode (brown-white-brown). Note banded end.
- ( ) 50 pf mica.
- ( ) 100 pf mica.
- ( ) .001  $\mu$ fd disc.
- ( ) .02  $\mu$ fd disc.
- ( ) 10  $\mu$ fd electrolytic. Note (+) marking.
- ( ) 50 pf mica.
- ( ) Silicon diode (#57-27). Note cathode end.
- ( ) .02  $\mu$ fd disc.
- ( ) .005  $\mu$ fd disc.
- ( ) Zener diode (#56-25). Note cathode end.
- ( ) .005  $\mu$ fd disc.
- ( ) .2  $\mu$ fd resin. Note banded end.
- ( ) Check to see that all connections are soldered, and cut off the excess leads.

PROCEED TO PICTORIAL 1-13

PICTORIAL 1-12

## START



## Bandpass Circuit Board-Continued

NOTE: Solder the connections of each part as it is installed. Do not cut off the lugs of these parts after soldering.

- ( ) Cut off the ground clip of a 9-pin tube socket.

CUT OFF GROUND CLIP.

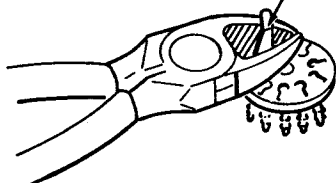

- ( ) Install this tube socket at V5.
- ( ) Install 9-pin tube sockets at V12, V17, and V19.
- ( ) 8-50 pf trimmer capacitor (#31-36). Note position of "Y" on trimmer and circuit board.

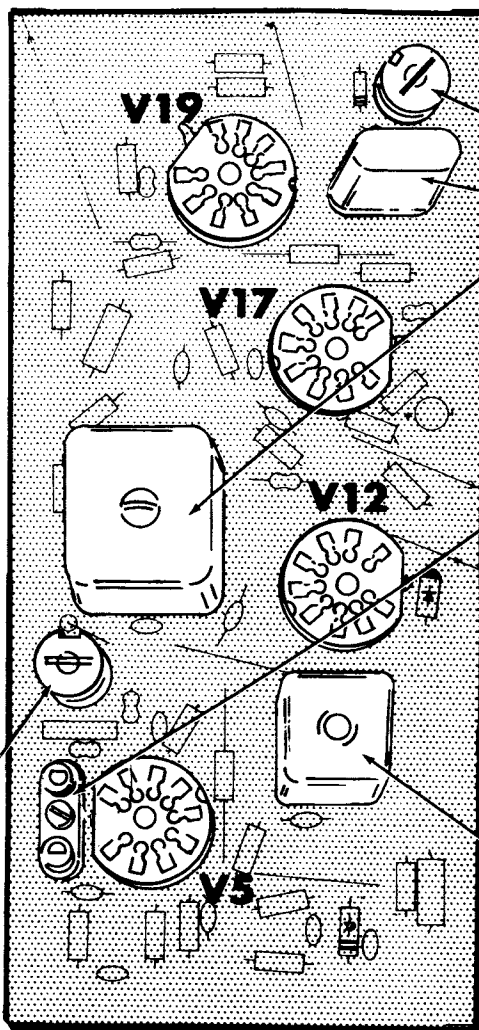
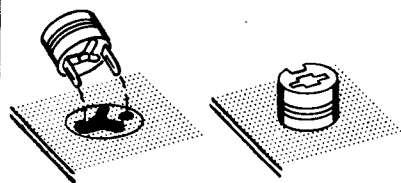

## CONTINUE



- ( ) 8-50 pf trimmer capacitor (#31-36). Note position of "Y" on trimmer and circuit board.
- ( ) 100 kHz crystal (#404-43).
- ( ) 8.4-8.9 MHz bandpass transformer (#52-65).

- ( ) Crystal socket. Use a 3-48 x 7/16" screw, a #3 lockwasher, and a 3-48 nut. Do not overtighten the hardware as the socket can be broken. Solder both lugs.

3-48x7/16" SCREW

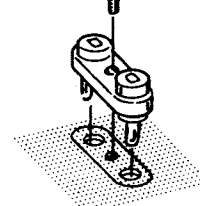

#3 LOCKWASHER  
3-48 NUT

- ( ) 3,395 MHz transformer (#52-79). Do not solder the two pins that do not have a foil.
- ( ) Check to see that all connections are soldered.

## FINISH

PROCEED TO PICTORIAL 1-14

PICTORIAL 1-13

**START**



Audio Circuit Board #85-130-1
( ) 47 K $\Omega$ (yellow-violet-orange).
( ) 22 K $\Omega$ (red-red-orange).
( ) 1000 $\Omega$ (brown-black-red).
( ) 4700 $\Omega$ (yellow-violet-red).
( ) 330 K $\Omega$ (orange-orange-yellow).
( ) 3300 $\Omega$ 1 watt (orange-orange-red).
( ) .005 $\mu$ fd disc.
( ) .005 $\mu$ fd disc.
( ) 150 K $\Omega$ (brown-green-yellow).
( ) 330 K $\Omega$ (orange-orange-yellow).
( ) 1 megohm (brown-black-green).
( ) .005 $\mu$ fd disc.
( ) .001 $\mu$ fd disc.
( ) 470 K $\Omega$ (yellow-violet-yellow).
( ) .005 $\mu$ fd disc.

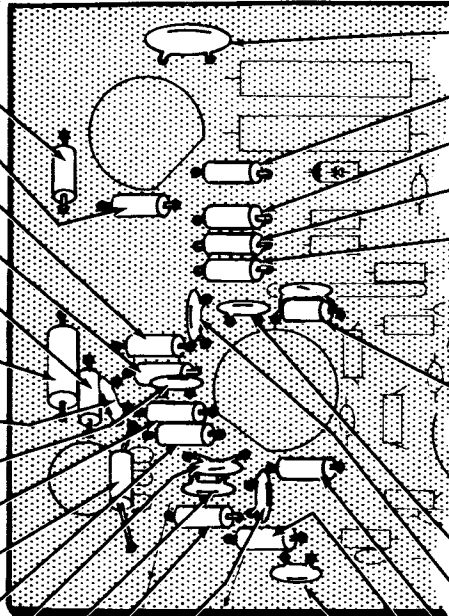

**CONTINUE**



( ) .02 $\mu$ fd disc.
( ) 47 K $\Omega$ (yellow-violet-orange).
( ) 47 K $\Omega$ (yellow-violet-orange).
( ) 47 K $\Omega$ (yellow-violet-orange).
( ) 47 K $\Omega$ (yellow-violet-orange).
( ) 47 K $\Omega$ (yellow-violet-orange).
( ) 47 K $\Omega$ (yellow-violet-orange) and a 500 pf disc combination.
( ) .005 $\mu$ fd disc.
( ) .01 $\mu$ fd disc.
( ) 22 K $\Omega$ (red-red-orange).
( ) 470 K $\Omega$ (yellow-violet-yellow).
( ) .005 $\mu$ fd disc.
( ) Check to see that all connections are soldered, and cut off the excess leads.

PICTORIAL 1-14

PROCEED TO PICTORIAL 1-15

**START**



Audio Circuit Board-continued
( ) Silicon diode (#57-27). Note cathode end.
( ) 680 KΩ (blue-gray-yellow).
( ) 680 KΩ (blue-gray-yellow).
( ) 470 KΩ (yellow-violet-yellow).
( ) 100 Ω (brown-black-brown).
( ) 1 megohm (brown-black-green).
( ) .02 μfd disc.
( ) .02 μfd disc.
( ) 100 Ω (brown-black-brown).
( ) 100 KΩ (brown-black-yellow).
( ) .005 μfd disc.
( ) 470 KΩ (yellow-violet-yellow).
( ) .005 μfd disc.

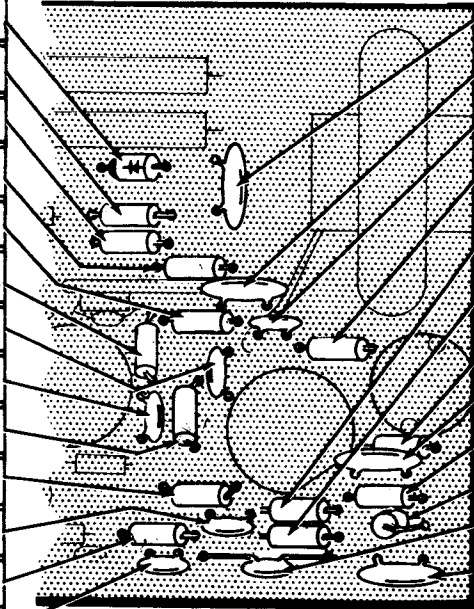

**CONTINUE**



( ) .02 μfd disc.
( ) .02 μfd disc.
( ) .001 μfd disc.
( ) 22 KΩ (red-red-orange).
( ) 220 KΩ (red-red-yellow).
( ) 3.3 megohm (orange-orange-green).
( ) 330 Ω (orange-orange-brown).
( ) .02 μfd disc.
( ) 470 KΩ (yellow-violet-yellow).
( ) 2.2 megohm (red-red-green).
( ) .005 μfd disc.
( ) .02 μfd disc.
( ) Check to see that all connections are soldered and cut off the excess leads.

PROCEED TO PICTORIAL 1-16

PICTORIAL 1-15

**START****Audio Circuit Board-Continued**

**NOTE:** Solder the connections of each part as it is installed. Cut off only the leads of the 7 watt resistors and the P.E.C. after soldering.

( ) Install a 7-pin tube socket at V18.

( ) Install 9-pin tube sockets at V14 and V15.

( ) 1000  $\Omega$  7 watt. Use 1/2" of sleeving on each lead.

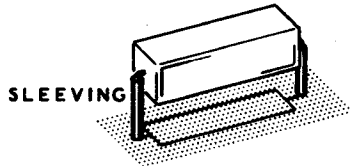

( ) 2500  $\Omega$  7 watt. Use 1/2" of sleeving on each lead.

( ) P.E.C. (#84-22).

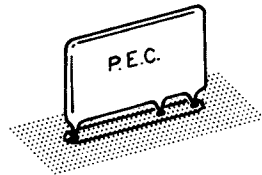

( ) 500 K $\Omega$  control (#10-149). Mount the control from the foil side of the circuit board. Be sure to solder the rear of the control cover to the foil.

( ) 20  $\mu$ fd electrolytic. Note (+) marking.

( ) Check to see that all connections are soldered.

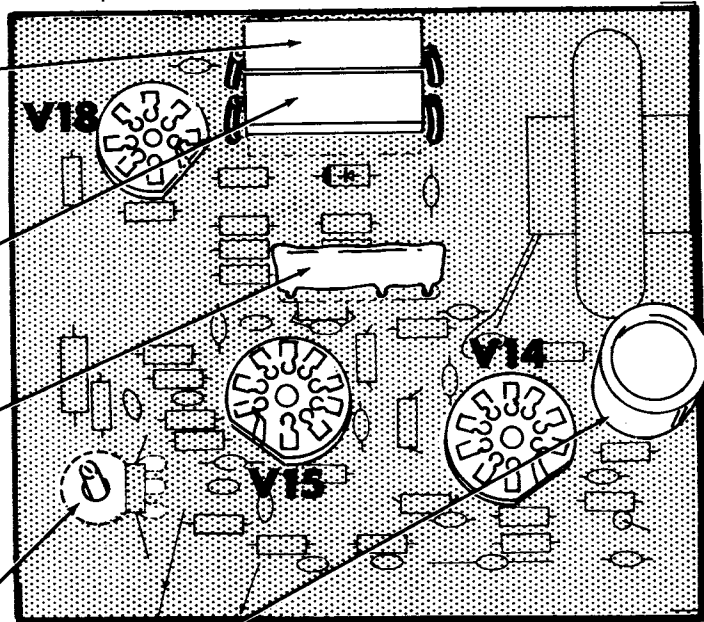
**FINISH**

PROCEED TO PICTORIAL 1-17

PICTORIAL 1-16

**START**



**CONTINUE**



RF-Driver Circuit Board #85-131-2
( ) .005 $\mu$ fd disc.
( ) .02 $\mu$ fd disc.
( ) .02 $\mu$ fd disc.
( ) .02 $\mu$ fd disc.
( ) .02 $\mu$ fd disc.
( ) .02 $\mu$ fd disc.
( ) 22 K $\Omega$ (red-red-orange).
( ) 1 megohm (brown-black-green).
( ) 100 K $\Omega$ (brown-black-yellow).
( ) 2-1/4" wire. Use black hookup wire with 1/2" of insulation removed from each end.
( ) .001 $\mu$ fd disc.
( ) .02 $\mu$ fd disc.
( ) 330 $\Omega$ (orange-orange-brown).
( ) 100 K $\Omega$ (brown-black-yellow).
( ) 24 pf mica.
( ) 10 K $\Omega$ (brown-black-orange).
( ) 470 K $\Omega$ (yellow-violet-yellow).
( ) .02 $\mu$ fd disc.

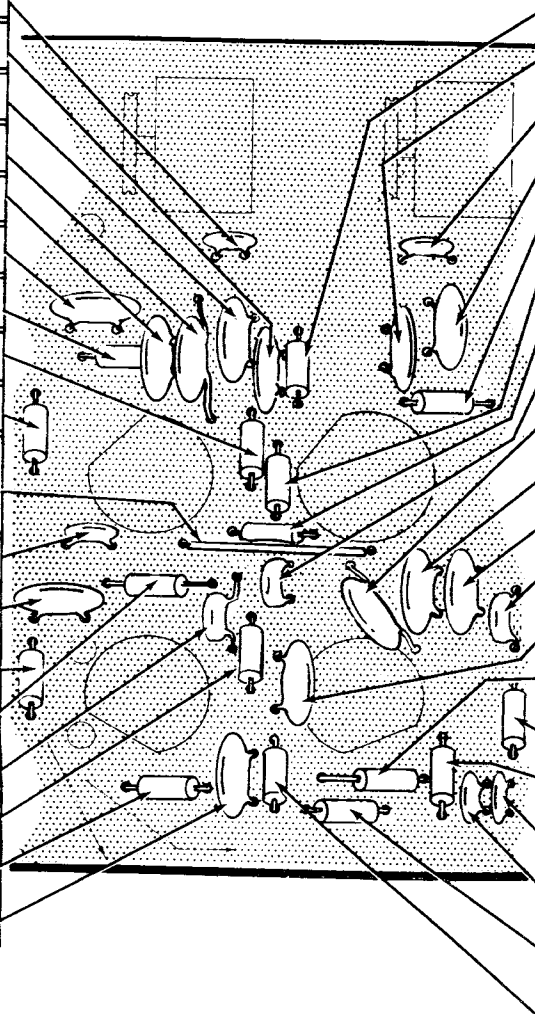

( ) 150 $\Omega$ (brown-green-brown).
( ) .02 $\mu$ fd disc.
( ) .005 $\mu$ fd disc.
( ) .02 $\mu$ fd disc.
( ) 4700 $\Omega$ (yellow-violet-red).
( ) 100 K $\Omega$ (brown-black-yellow).
( ) 150 K $\Omega$ (brown-green-yellow)
( ) 180 pf mica.
( ) .02 $\mu$ fd disc.
( ) .02 $\mu$ fd disc.
( ) .02 $\mu$ fd disc.
( ) 24 pf mica.
( ) .02 $\mu$ fd disc.
( ) 1 megohm (brown-black-green).
( ) 100 K $\Omega$ (brown-black-yellow).
( ) 100 K $\Omega$ (brown-black-yellow).
( ) .005 $\mu$ fd disc.
( ) .005 $\mu$ fd disc.
( ) 3.3 megohm (orange-orange-green).
( ) 220 $\Omega$ (red-red-brown).
( ) Check to see that all connections are soldered, and cut off the excess leads.

PROCEED TO PICTORIAL 1-18

PICTORIAL 1-17



**START****RF-Driver Circuit Board-Continued**

**NOTE:** Solder the connections of each part as it is installed. Do not cut off the lugs of these parts after soldering.

( ) Install 7-pin tube sockets at V6, V10, and V11.

( ) Install a 9-pin tube socket at V7.

**CAUTION:** Keep the plates of variable capacitors closed at all times to prevent them from being damaged during the assembly of the kit.

( ) Locate a 2-section variable capacitor (#26-122) and place it in front of you as it is shown below. If there are no lugs 4 and 5 on this capacitor, proceed to the next step. If there is a lug 4 and a lug 5, bend these lugs up as shown.

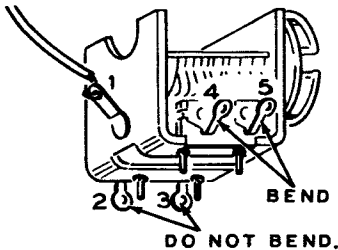

( ) Connect one end of a 2" wire to lug 1 of this capacitor (S-1). Use black hookup wire with 1/4" of insulation removed from both ends.

**NOTE:** This capacitor will be mounted later.

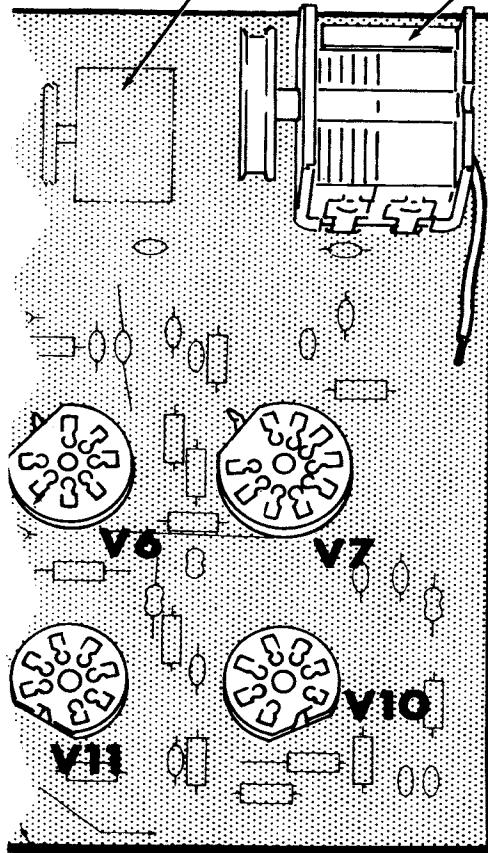

PICTORIAL 1-18

**CONTINUE**

( ) 2-section variable capacitor.

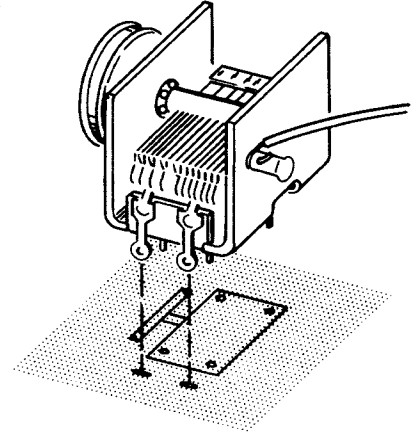

( ) Check to see that all connections are soldered.

**FINISH**

The remaining black hookup wire, solder, and sleeving should be retained for use later. All other parts selected at the beginning of this section of the Manual should have been used in the assembly of the circuit boards.

**CHASSIS PARTS LIST**

Unpack the remaining parts; then check each part against the following Parts List. The numbers in parentheses correspond to the numbers in the parts pictorials. Do not open small envelopes with part numbers on them until those parts are called for in steps.

<u>PART No.</u>	<u>PARTS Per Kit</u>	<u>DESCRIPTION</u>
<b>RESISTORS</b>		
<b>1/2 Watt</b>		
(1)1-41	6	10 $\Omega$ (brown-black-black)
1-83	1	56 $\Omega$ (green-blue-black)
1-3	4	100 $\Omega$ (brown-black-brown)
1-4	1	330 $\Omega$ (orange-orange-brown)
1-96	1	750 $\Omega$ (violet-green-brown)

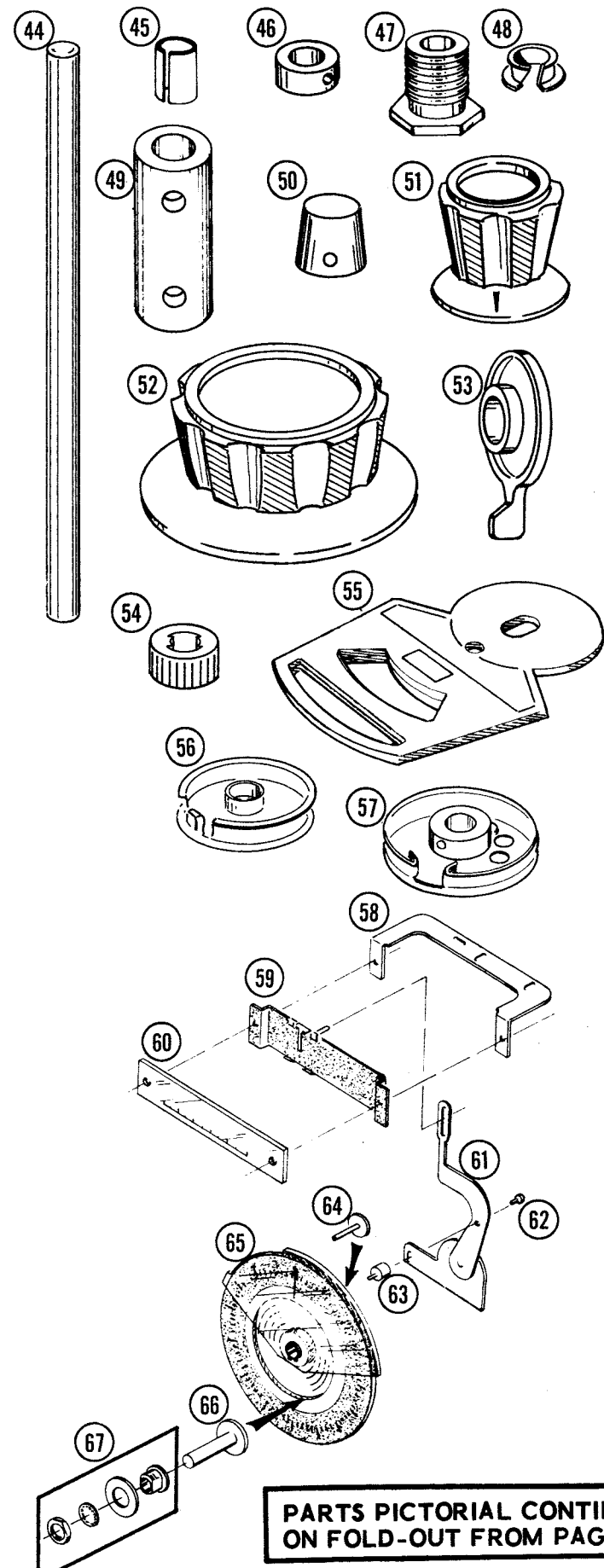
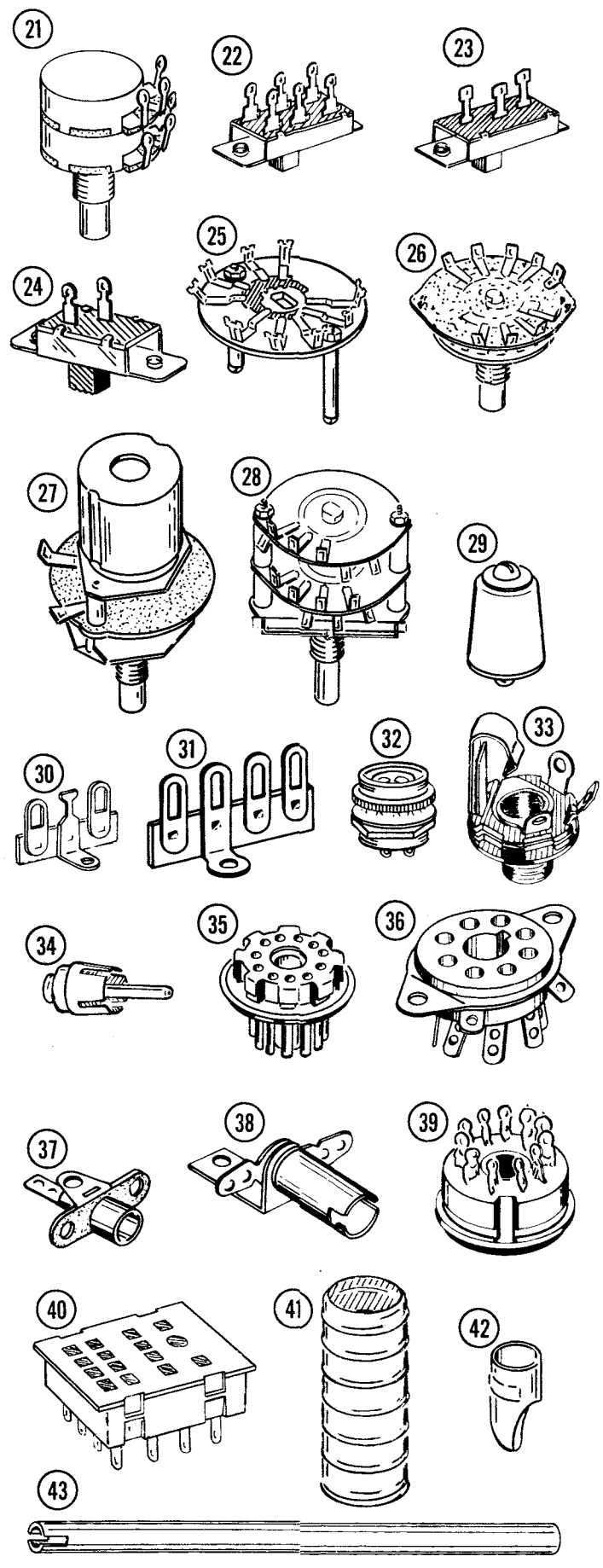
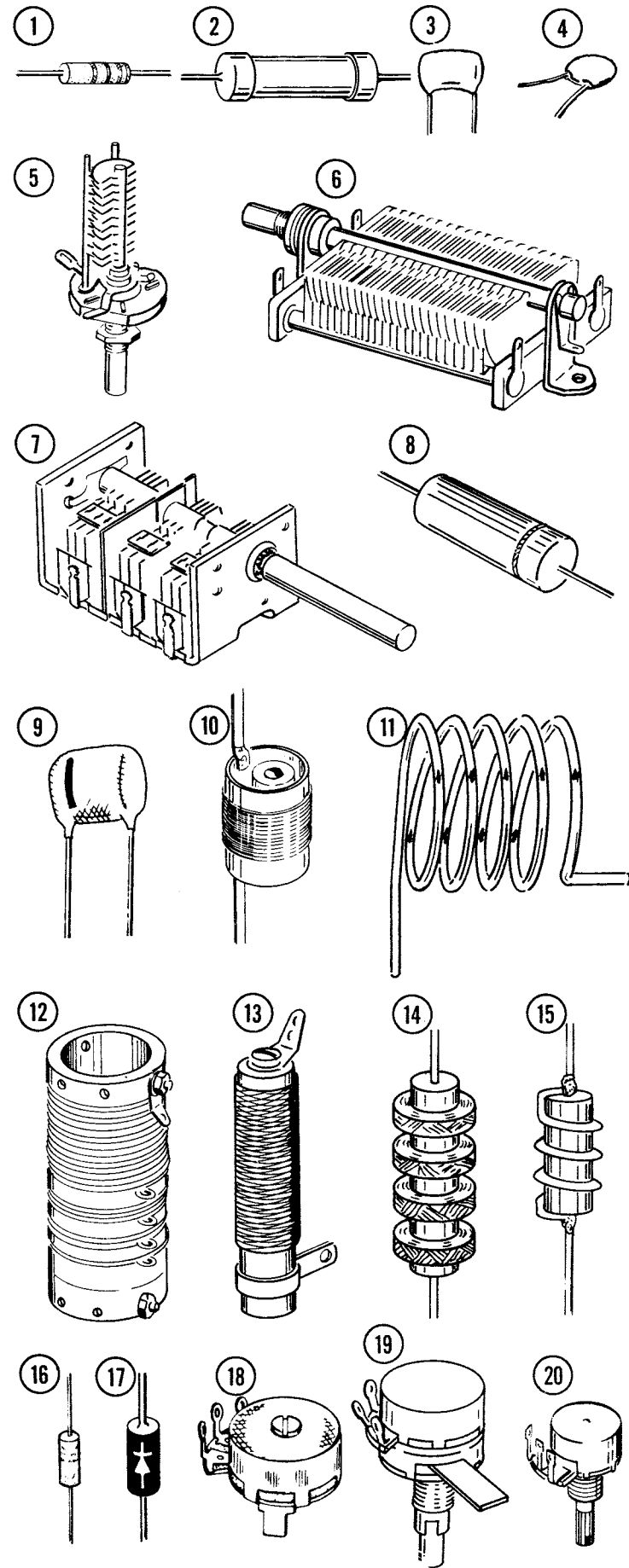

PARTS PICTORIAL CONTINUED ON FOLD-OUT FROM PAGE 25.

PART No.	PARTS Per Kit	DESCRIPTION	PART No.	PARTS Per Kit	DESCRIPTION
<b>Resistors (cont'd.)</b>			<b>DIODES</b>		
1-9	1	1000 $\Omega$ (brown-black-red)	(16)56-26-1	1	1N191 germanium
1-90	1	2000 $\Omega$ (red-black-red)	(17)57-27	4	Silicon 750 ma 500 PIV
1-16	1	4700 $\Omega$ (yellow-violet-red)	<b>CONTROLS</b>		
1-20	3	10 K $\Omega$ (brown-black-orange)	(18)10-57	3	10 K $\Omega$ tab mount
1-22	2	22 K $\Omega$ (red-red-orange)	(19)10-208	1	100 K $\Omega$ with switch lever
1-25	1	47 K $\Omega$ (yellow-violet-orange)	10-68	1	500 K $\Omega$
1-35	1	1 megohm (brown-black-green)	(20)10-153	2	1 megohm miniature
1-37	1	2.2 megohm (red-red-green)	10-154	1	10 megohm miniature
1-38	1	3.3 megohm (orange-orange-green)	(21)12-48	1	10 K $\Omega$ and 1 megohm dual
<b>Precision (1/2 Watt)</b>			<b>SWITCHES</b>		
(2) 2-76	2	500 K $\Omega$ 1%	(22) 60-2	1	DPDT slide
<b>CAPACITORS</b>			(23) 60-4	1	SPDT slide
<b>Mica</b>			(24) 60-1	1	SPST slide
(3) 20-130	2	12 pf	(25) 63-395	1	Rotary wafer (blue dot)
20-77	2	24 pf	(26) 63-400	1	3-position single wafer
20-102	2	100 pf	63-94	1	5-position single wafer
20-105	3	180 pf	(27) 63-349	1	4-position single wafer with snap switch
<b>Disc</b>			(28) 63-399	1	4-position double wafer
(4) 21-14	3	.001 $\mu$ fd	<b>INSULATORS</b>		
21-27	15	.005 $\mu$ fd	(29) 71-4	2	Standoff
21-44	2	.005 $\mu$ fd 1.6 KV	73-3	4	1/2" rubber grommet
21-16	1	.01 $\mu$ fd	73-46	5	5/16" plastic grommet
21-31	5	.02 $\mu$ fd	<b>TERMINAL STRIPS</b>		
<b>Other Capacitors</b>			(30) 431-62	2	3-lug miniature
(5) 26-24	1	20 pf variable	(31) 431-12	3	4-lug
(6) 26-77	1	250 pf variable	431-11	1	5-lug
26-122	1	2-section variable	431-45	1	6-lug
(7) 26-92	1	3-section variable	<b>CONNECTORS-JACKS-PLUGS</b>		
(8) 23-59	1	.05 $\mu$ fd tubular	432-38	1	Male connector
(9) 27-34	3	.2 $\mu$ fd resin	(32) 432-39	1	Female connector
<b>COILS</b>			(33) 436-4	1	3-lug jack
(10) 40-546	1	8.5 MHz trap coil	436-21	1	4-lug jack
(11) 40-549	1	10-meter coil	(34) 438-4	8	Phono plug
(12) 40-548	1	Final tank coil	(35) 438-29	1	11-pin plug
<b>CHOKES</b>			<b>SOCKETS</b>		
(13) 45-41	1	425 $\mu$ h	(36) 434-39	2	Octal
(14) 45-30	1	.5 mh	(37) 434-42	7	Phono
(15) 45-53	2	Parasitic	(38) 434-44	3	Pilot lamp
			(39) 434-118	1	11-pin
			(40) 434-143	2	Relay



PART No.	PARTS Per Kit	DESCRIPTION	PART No.	PARTS Per Kit	DESCRIPTION
<b>SHIELDS</b>			<b>DIAL PARTS</b>		
(41) 206-77	1	Small tube, 1-3/4" long	268-7	3	Rubber belt
206-68	1	Large tube, 1-3/4" long	(55) 446-40	1	Dial escutcheon
206-206	1	Large tube, 2" long	(56) 466-6	2	3/4" diameter pulley
(42) 206-86	3	Pilot lamp	(57) 100-19	1	Dial pulley with 1/4" hole
			100-458	1	Dial pulley with 9/32" hole (red color dot)
<b>TUBES-PILOT LAMPS</b>			<b>#100-450 Packaged Dial Drive Assembly, consisting of the following:</b>		
411-59	1	OA2 tube	(58) 204-553	1	Dial mounting bracket
411-11	5	6AU6 tube	(59) 100-443	1	Dial pointer assembly
411-128	1	6BN8 tube	(60) 464-30-1	1	Plastic dial window
411-67	1	6CB6 tube	(61) 100-447	1	Dial pointer drive arm
411-63	1	6CL6 tube	(62) 250-63	1	3-48 x 1/8" screw
411-124	4	6EA8 tube	(63) 266-74	1	Nylon spiral follower
411-173	1	6GW8 tube	(64) 100-445	1	Zero set drive pulley (small)
411-24	2	12AT7 tube	(65) 100-449	1	Circular dial
411-25	1	12AU7 tube	(66) 100-444	1	Dial drive pulley (large)
411-75	2	6146 tube	(67) 455-42	1	Drive shaft bushing package
412-14	3	#44 pilot lamp			
<b>HARNESSES-WIRE-SLEEVING</b>			<b>METAL PARTS</b>		
134-121	1	Wire harness	90-341	1	Cabinet
134-122	1	Coaxial cable harness	100-554	1	RF cage
340-3	1	Small bare wire	consisting of the following:		
340-2	1	Large bare wire	(68)	1	RF cage rear plate
346-2	2	Large sleeving	(69)	1	RF cage top plate
343-7	1	Coaxial cable (RG-174/U)	(70)	1	RF cage
344-51	1	Brown hookup wire	(71) 204-573	1	Capacitor bracket
344-59	1	White hookup wire	(72) 204-588-1	1	Control bracket
344-21	1	Large red hookup wire	(73) 200-479-1	1	Chassis
			(74) 203-358-2	1	Front panel
			(75) 204-560	2	Support rail
			(76) 204-677	2	Comb bracket
			(77) 206-281	1	Final shield
			(78) 206-282	2	Switch shield
			(79) 206-280	1	Center shield
			(80) 204-737	1	Crystal filter bracket
			(81) 204-738	1	Switch bracket
			(82) 205-493-1	1	Coil cover
			(83) 266-97	1	Slide switch actuator
<b>SHAFTS-BUSHINGS-SHAFT COUPLING</b>					
(43) 453-146	1	8-1/4" long tubular shaft			
(44) 453-17	1	9" long shaft			
453-125	1	9-3/8" long shaft			
453-147	1	11-1/4" long shaft			
(45) 455-11	3	Split bushing			
(46) 455-15	2	1/4" shaft collar			
(47) 455-10	1	3/8" long bushing			
455-18	1	9/16" long bushing			
(48) 455-44	1	Nylon bushing			
(49) 456-4	1	Shaft coupling			
<b>KNOBS-KNOB INSERT</b>					
(50) 462-175	1	7/16" diameter aluminum			
(51) 462-191	10	1-1/8" diameter			
(52) 462-193	1	2-1/2" diameter			
(53) 462-218	2	Lever			
(54) 455-52	2	Knob insert			

PART No.	PARTS Per Kit	DESCRIPTION
----------	---------------	-------------

PART No.	PARTS Per Kit	DESCRIPTION
----------	---------------	-------------

**TOOLS**

490-1	1	Alignment
(84) 490-19	1	Open-end wrench
(85) 490-23	1	#4 allen wrench
490-85	1	#8 allen wrench

**1/4" Control Hardware**

(113) 252-39	3	1/4-32 nut
(114) 253-36	1	1/4" dished washer
(115) 253-39	3	1/4" flat washer
253-49	1	1/4" nylon flat washer
(116) 75-18	1	1/4" nylon shoulder washer
(117) 253-62	2	1/4" fiber flat washer
(118) 259-12	4	1/4" solder lug

**HARDWARE**
**#3 Hardware**

(86) 250-172	82	3-48 x 3/8" screw
(87) 250-251	2	3-48 x 3/8" flat head screw
(88) 252-1	84	3-48 nut
(89) 254-7	164	#3 lockwasher
(90) 258-5	10	#3 spring clip

**3/8" Control Hardware**

(119) 252-7	14	3/8-32 nut
(120) 253-10	14	3/8" flat washer
(121) 254-5	5	3/8" lockwasher
(122) 259-10	6	3/8" solder lug

**#6 Hardware**

(91) 250-56	11	6-32 x 1/4" screw
(92) 250-89	36	6-32 x 3/8" screw
(93) 250-276	8	6-32 x 3/8" flat head screw
(94) 250-218	2	6-32 x 3/8" phillips head screw
(95) 250-284	20	#6 x 1/2" sheet metal screw
(96) 250-26	4	6-32 x 5/8" screw
(97) 250-40	2	6-32 x 1-1/2" screw
(98) 252-3	50	6-32 nut (2 spare)
(99) 253-1	2	#6 fiber flat washer
(100) 253-2	3	#6 fiber shoulder washer
253-60	5	#6 flat washer
(101) 254-1	67	#6 lockwasher (4 spare)
(102) 255-79	1	Threaded shoulder spacer
(103) 259-6	3	Small #6 solder lug
(104) 259-1	3	Large #6 solder lug

**Other Hardware**

(123) 252-15	4	4-40 nut
(124) 254-9	6	#4 lockwasher
(125) 250-156	1	4-40 x 1/8" setscrew
(126) 207-22	1	Cable clamp
(127) 260-39	2	Anode clip (may vary in appearance)
(128) 435-1	1	11-pin plug retaining ring
(129) 435-10	2	Relay socket retaining ring

**MISCELLANEOUS**

(130) 51-123	1	Output transformer
(131) 69-35	2	4PDT relay
74-6	2	Masking tape
110-40	1	LMO (linear master oscillator)
(132) 255-59	2	Foot spacer
(133) 261-9	4	Rubber foot
(134) 266-85	2	Rotary switch detent
390-147	1	High voltage label
391-49	1	SB-101 nameplate
(135) 404-283	1	2.1 kHz crystal filter
407-101	1	Meter
(136) 440-1	1	11-pin socket cap
352-13	1	Silicone grease
(137) 263-7	1	Felt pad

**#8 Hardware**

(105) 250-93	19	#8 x 1/4" setscrew
(106) 250-260	2	8-32 x 1/4" oval head screw
(107) 250-72	1	8-32 x 3/4" screw
(108) 252-4	1	8-32 nut
(109) 252-28	1	8-32 knurled nut
(110) 253-45	2	#8 flat washer
(111) 254-2	1	#8 lockwasher
(112) 259-2	1	#8 solder lug

# PARTS PICTORIAL (cont'd.)

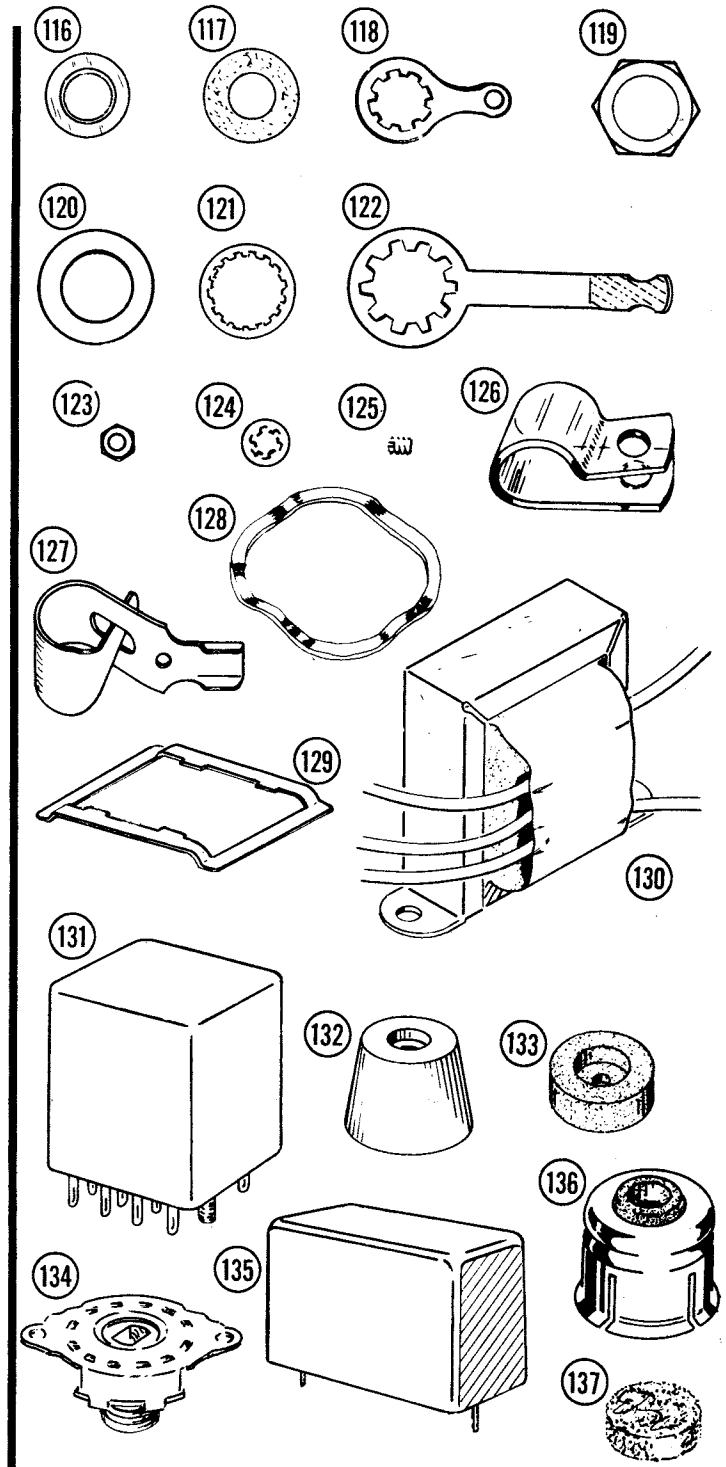
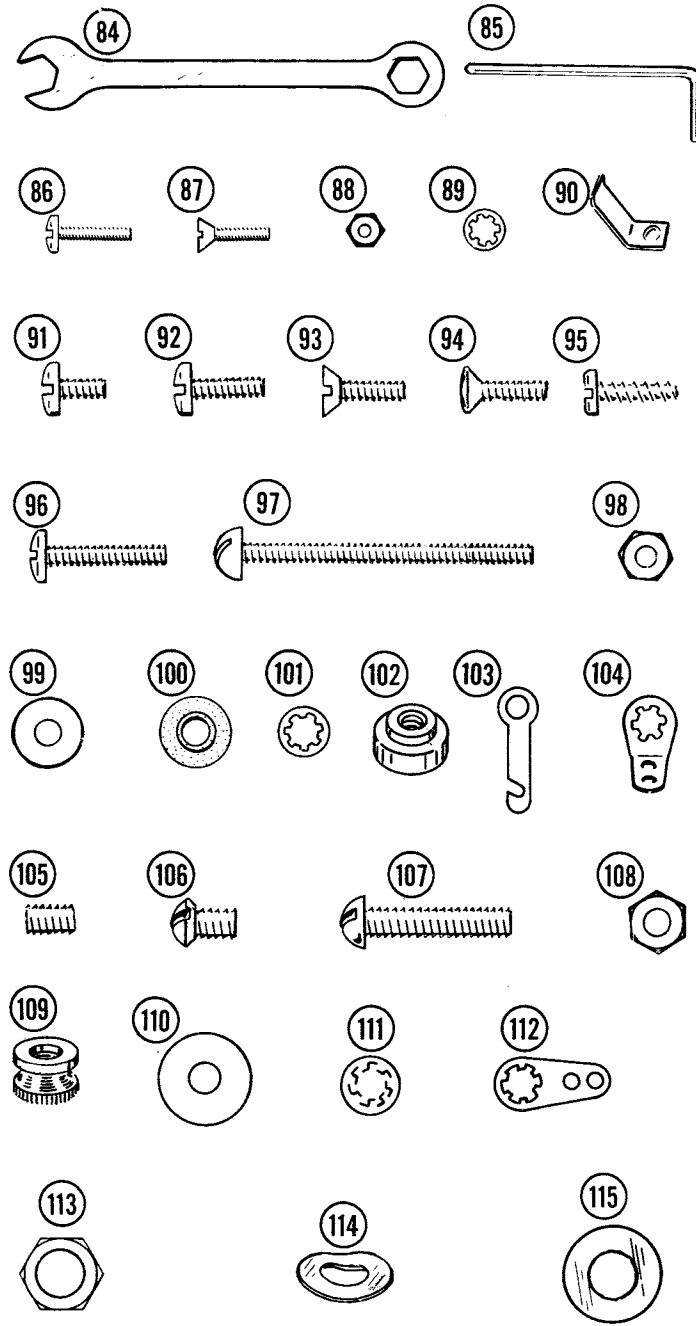
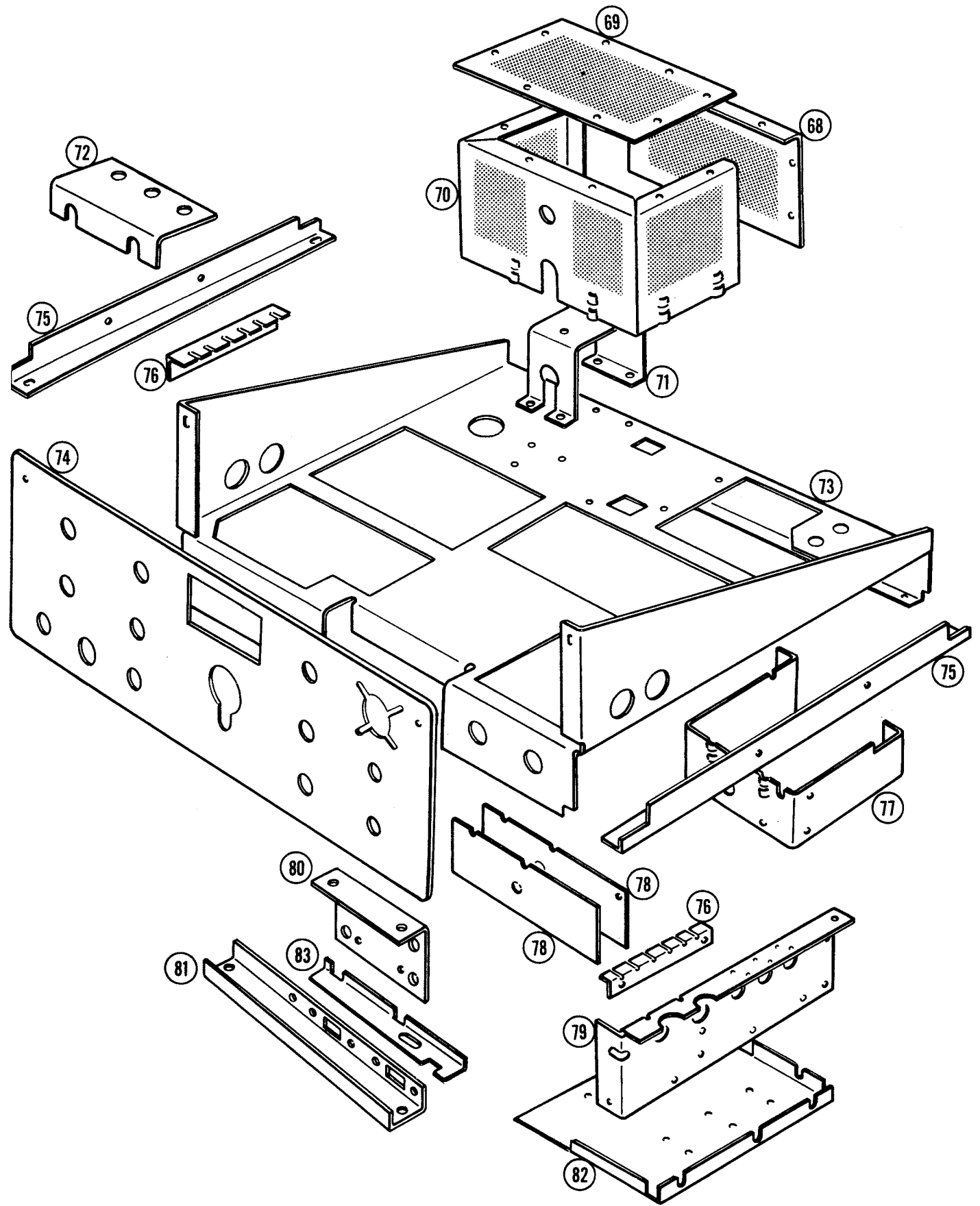

## CHASSIS ASSEMBLY

Lockwashers and nuts will be used with most screws when mounting parts, unless the step directs otherwise. Consequently, only the size and type of hardware to be used will generally be called out in a step. For example, the phrase "Use 3-48 x 3/8" hardware" means to use a 3-48 x 3/8" screw, one or more #3 lockwashers, and a 3-48 nut. Refer to the Details associated with the step for the proper installation of the hardware and the correct number of lockwashers. Be sure to use the flat head and oval head screws only when they are called for in a step.

Refer to Page 3 of the Kit Builders Guide for the use of the nut starter.

### PARTS MOUNTING

Refer to Pictorial 2-1 for the following steps.

Because of the nature of the dial mechanism used in this kit, it is very important that the front edges of the chassis be in perfect alignment. This is checked at the factory. However, if the kit receives rough handling in shipment, this alignment might be changed. Check the alignment of the front edges of the chassis as directed in the following step; use care in handling the chassis throughout the assembly of the kit.

( ) Referring to Detail 2-1A, check to see that the front flange of the chassis is in perfect alignment with the front edges of the side aprons. This can be done by placing a ruler or other straight edge along this surface as shown. Straighten the front flange of the chassis as required, by carefully bending the flange.

( ) Refer to Detail 2-1B and install a phono socket at AB. Use 6-32 x 3/8" hardware. Position the socket as shown.

( ) In a like manner, install phono sockets at AC, AD, AE, AF, AJ, and AL. Use 6-32 x 3/8" hardware. Position each socket as shown.

( ) Refer to Detail 2-1C and install the 3-lug jack at AA. Use 3/8" control lockwasher, 3/8" control flat washer, and a 3/8-32 control nut. Position the jack as shown in Pictorial 2-1.

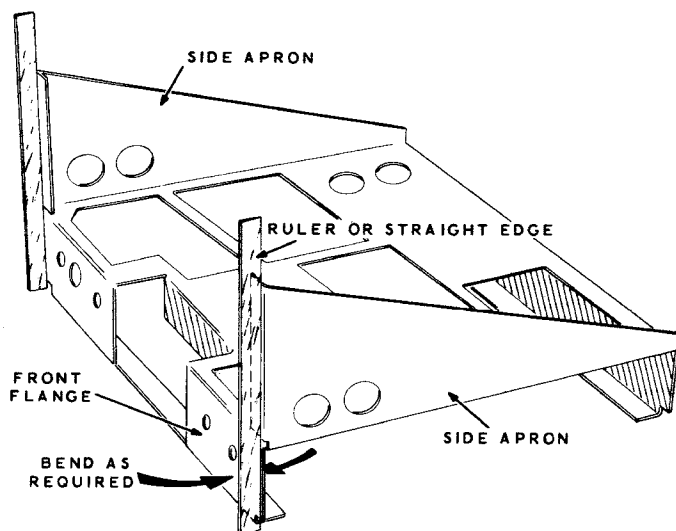

Detail 2-1A

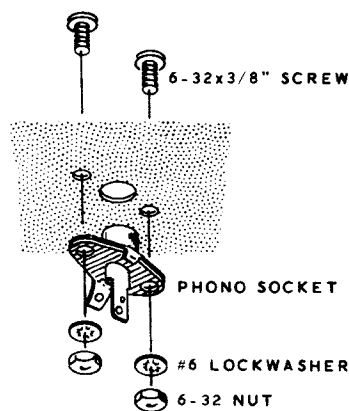

Detail 2-1B

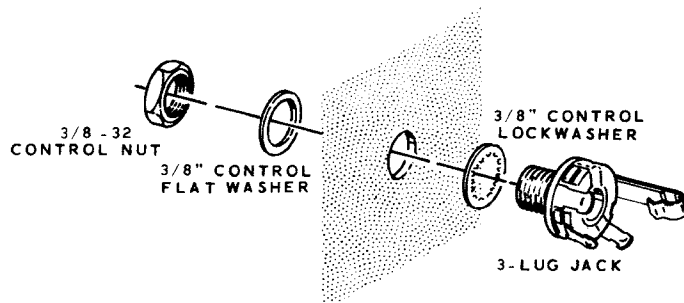

Detail 2-1C

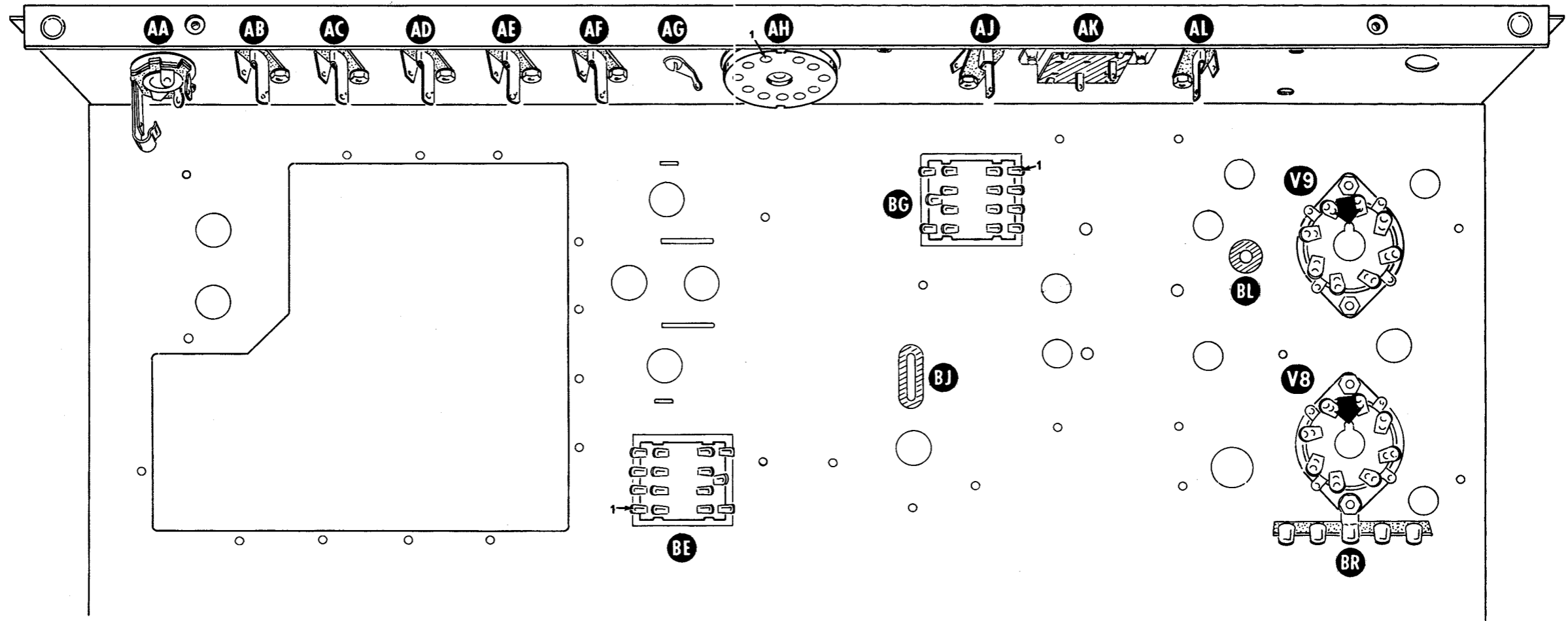

**PICTORIAL 2-1**



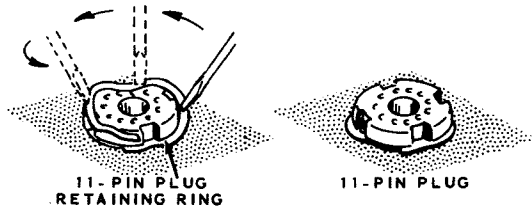

11-PIN PLUG  
RETAINING RING

11-PIN PLUG

HOLD THE PLUG IN THE CHASSIS HOLE AND PLACE ONE END OF THE RING INTO THE GROOVE OF THE PLUG. USING A SCREWDRIVER, PRESS THE RING INTO THE GROOVE AROUND THE PLUG.

Detail 2-1D

- ( ) Refer to Detail 2-1D and mount the 11-pin plug (#438-29) at AH, using the 11-pin plug retaining ring. Position pin 1 of the plug as shown. The pin numbers are molded into the plug.
- ( ) Referring to Detail 2-1E, install the 8-32 x 3/4" screw at AG. Use a #8 solder lug, a #8 lockwasher, and 8-32 nut, two #8 flat washers, and an 8-32 knurled nut. Position and bend the solder lug as shown.

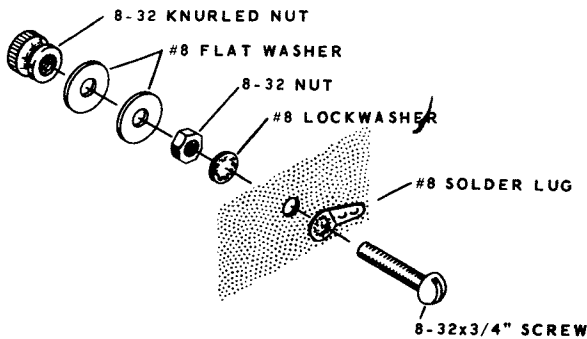

Detail 2-1E

- ( ) Refer to Detail 2-1F and install the SPST slide switch at AK. Use 6-32 x 1/4" screws. Position the switch as shown.

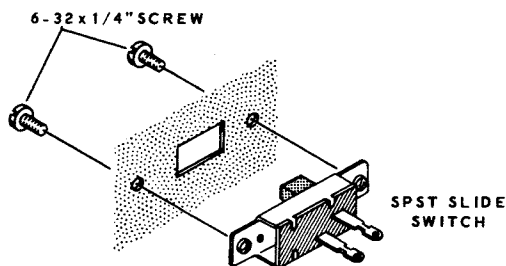

Detail 2-1F

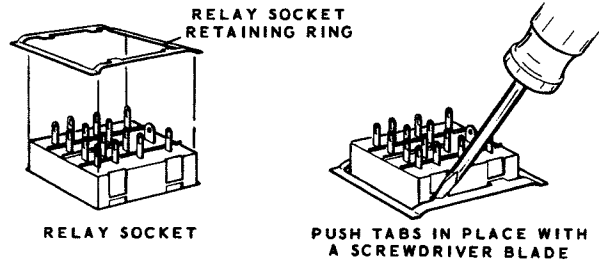

Detail 2-1G

- ( ) Refer to Detail 2-1G and install relay sockets at BE and BG. Use relay socket retaining rings. Position lug 1 of each socket as shown. The lug numbers are molded into the sockets. Be sure to push each ring down until all four tabs snap into place.
- ( ) Install a 1/2" rubber grommet at BJ.
- ( ) Refer to Detail 2-1H and install a 5/16" plastic grommet at BL.

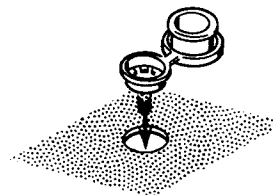

POSITION THE SMALL PORTION OF THE GROMMET INTO THE CHASSIS HOLE.

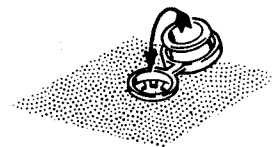

BEND THE LARGE PORTION OF THE GROMMET OVER AND INTO THE SMALL PORTION. PRESS IT FIRMLY INTO PLACE.

Detail 2-1H

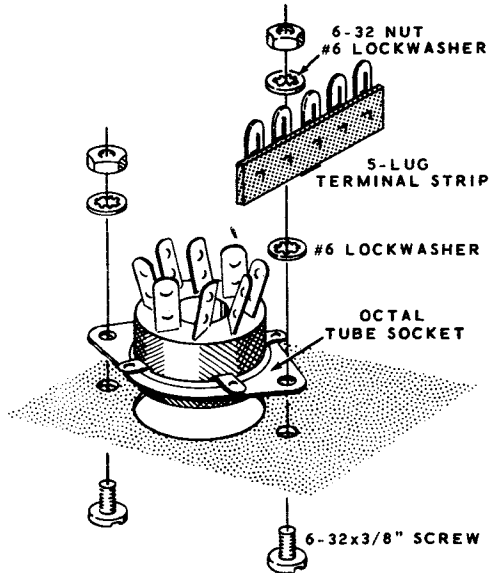

Detail 2-1J

- ( ) Referring to Detail 2-1J, install an octal tube socket at V8 with a 5-lug terminal strip at BR. Use 6-32 x 3/8" hardware. Position the keyway of the socket as indicated by the arrow, and the terminal strip as shown in Pictorial 2-1.
- ( ) In a similar manner, install an octal tube socket at V9. Use 6-32 x 3/8" hardware. Position the keyway of the socket as shown.

Refer to Pictorial 2-2 (fold-out from Page 35) for the following steps.

- ( ) Refer to Detail 2-2A and install a 100 K $\Omega$  control (#10-208) at P. Use a 3/8" control lockwasher, a 3/8" control flat washer, and a 3/8-32 control nut. Position the control as shown.
- ( ) Locate the switch bracket.
- ( ) Refer to Detail 2-2B and install a SPDT slide switch (#60-4) at EB on the switch bracket. Use two 6-32 x 1/4" screws. Position the switch lugs as shown.
- ( ) Similarly, install a DPDT slide switch (#60-2) at EC on the switch bracket. Use two 6-32 x 1/4" screws.

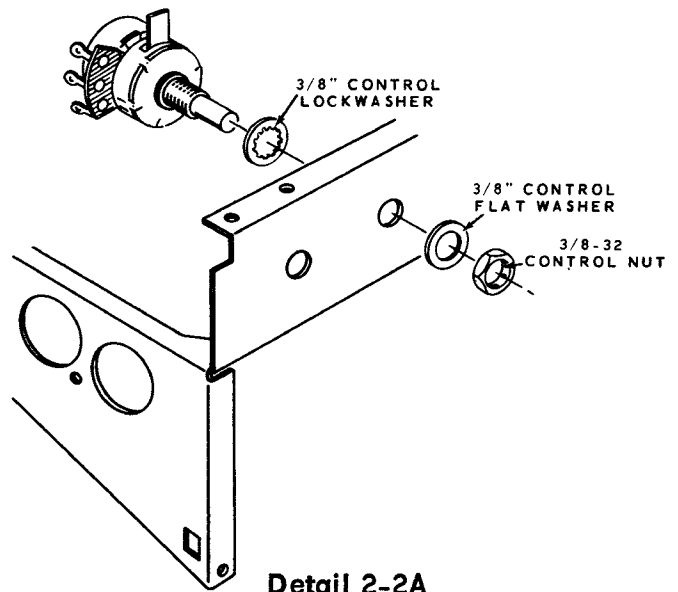

Detail 2-2A

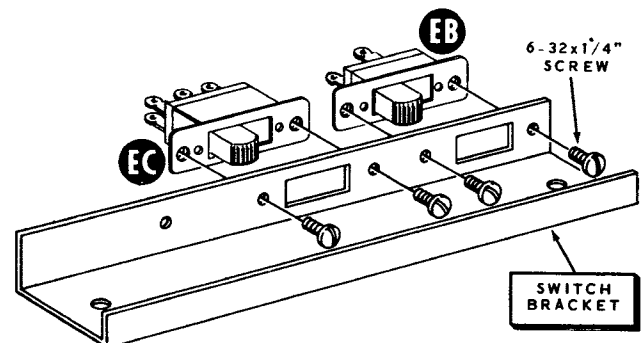

Detail 2-2B

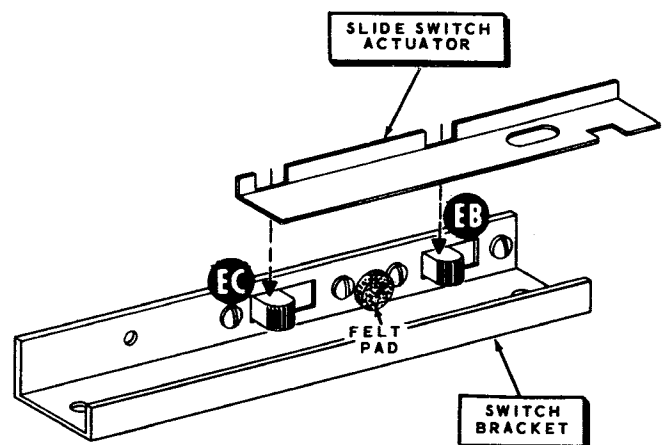

Detail 2-2C

- ( ) Refer to Detail 2-2C and place the slide switch actuator in position on the switch bracket.
- ( ) Remove the protective backing from the felt pad. Then press the felt pad in between the screw heads and onto the switch bracket as it is shown in Detail 2-2C.
- ( ) Place the switch bracket in position as shown in Detail 2-2D and secure one end to the chassis. Use a 6-32 x 3/8" flat head screw, a #6 lockwasher, and a 6-32 nut.

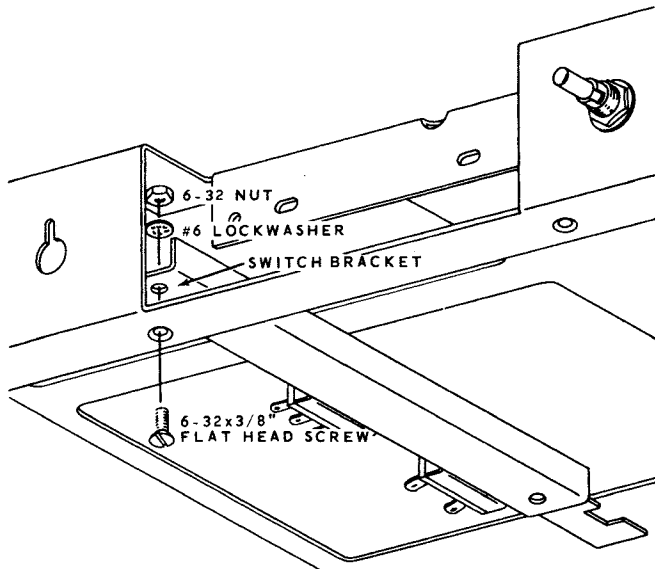

Detail 2-2D

- ( ) Refer to Detail 2-2E and swing the free end of the switch bracket into position. The slot in the slide switch actuator should fit over the switch actuator arm on control P. Secure the switch bracket with a 6-32 x 3/8" flat head screw and a threaded shoulder spacer as shown. Securely tighten both 6-32 screws holding the switch bracket.
- ( ) Place a knob insert on the outer (slotted) shaft of control P.
- ( ) Rotate the knob insert back and forth two or three times to make sure the slide switches operate properly.
- ( ) Remove the knob insert from control P.

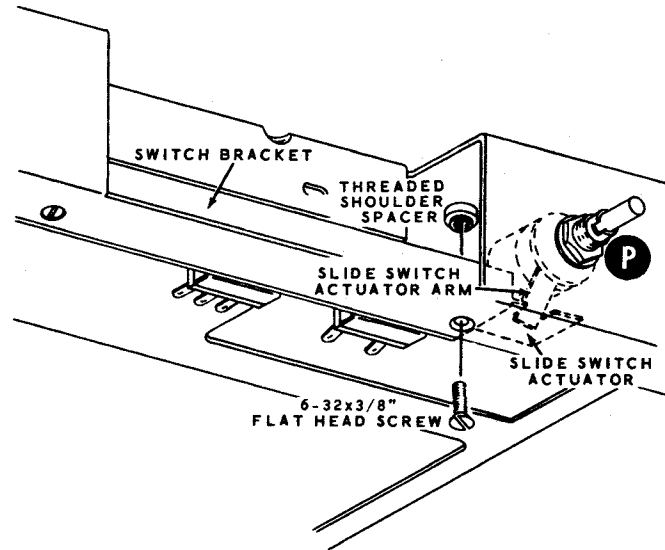

Detail 2-2E

Refer to Detail 2-2F for the following steps.

- ( ) Locate the center shield and install 5/16" plastic grommets at CA, CC, CD, and CE.
- ( ) Install 1/2" rubber grommets at CB and CF on the center shield.
- ( ) Install a comb bracket on the center shield, with 3-48 x 3/8" hardware. Position the comb bracket as shown.
- ( ) Mount the center shield in the chassis with #6 x 3/8" hardware at BZ and both BW locations. Do not tighten the hardware at this time.

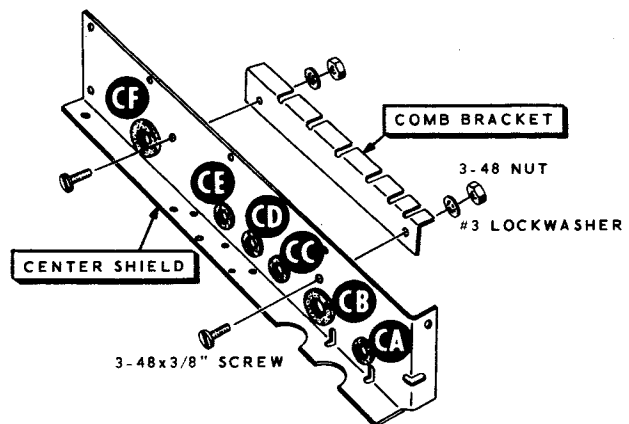

Detail 2-2F

Refer to Pictorial 2-2 for the following steps.

**NOTE:** When the circuit boards are mounted, lockwashers must be installed between the chassis and foil sides of the circuit boards. This assures a good ground between the circuit boards and the chassis. This operation can be simplified if you place a piece of masking tape over the screw heads after the screws are installed on the lettered side of the circuit board. This will hold the screws in place until lockwashers and nuts are installed. The tape should be removed after the nuts are installed.

- ( ) Refer to Detail 2-2G and mount the IF circuit board (#85-128-2) on the chassis. Use 3-48 x 3/8" hardware. Do not tighten the hardware at this time.

- ( - ) In a like manner, mount the bandpass circuit board (#85-129-2). Use 3-48 x 3/8" hardware. Be sure to position the circuit board properly. Do not tighten the hardware at this time. Refer to the inset drawing on Pictorial 2-2 for the proper installation of the hardware that goes through the center shield.

- ( ) Mount the modulator circuit board (#85-127-1) using 3-48 x 3/8" hardware.

- ( ) Mount the RF-driver circuit board (#85-131-2) with a small #6 solder lug at BT. Use 3-48 x 3/8" hardware, with a lockwasher on each side of the solder lug. Position and bend the solder lug as shown. Do not tighten the hardware at this time.

- ( ) Cut the leads of the output transformer (#51-123) to the lengths indicated in Detail 2-2H. Remove 1/4" of insulation from the lead ends. Then melt a small amount of solder on each exposed lead end to hold any loose strands of wire together.

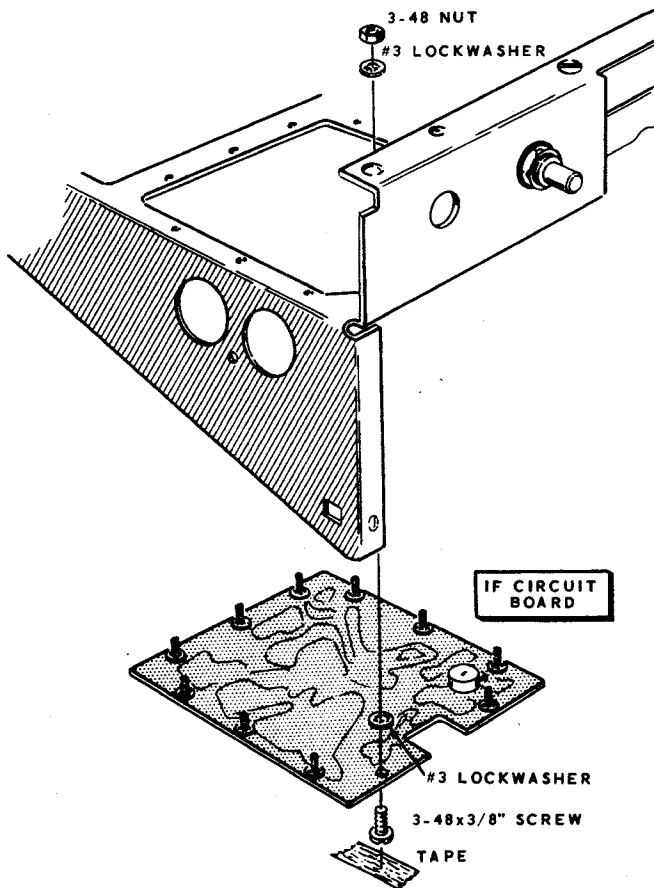

Detail 2-2G

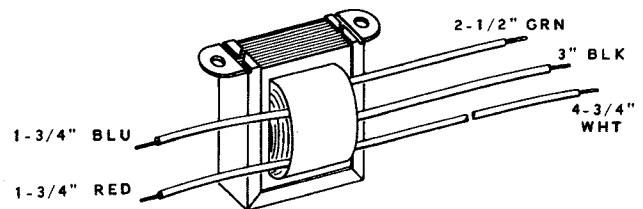

Detail 2-2H

**NOTE:** In the next step, the #6 lockwashers can be more easily installed between the circuit board and chassis if 6-32 x 3/8" screws are taped in place first, along with the 3-48 x 3/8" hardware. Then, the 6-32 x 3/8" screws can be removed, and the #6 lockwashers will remain in place while the output transformer and terminal strip are being installed.

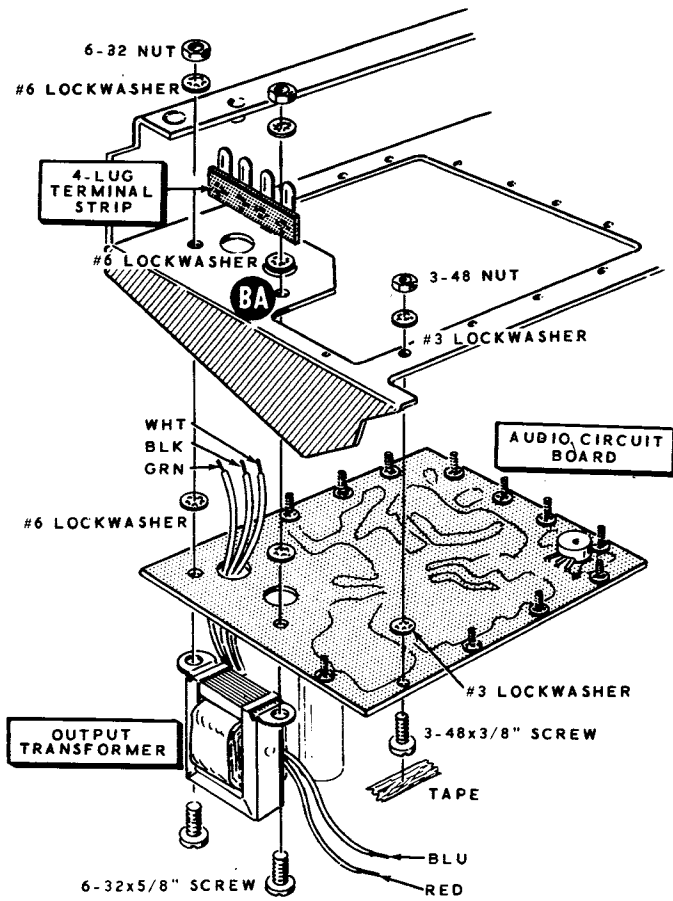

Detail 2-2J

- ( ) Refer to Detail 2-2J and mount the audio circuit board (#85-130-1) and output transformer with a 4-lug terminal strip at BA. Use 3-48 x 3/8" hardware to mount the circuit board, and 6-32 x 5/8" hardware to mount the transformer and terminal strip. Position the black, green, and white transformer leads down through the indicated hole in the chassis. Position the terminal strip as shown.

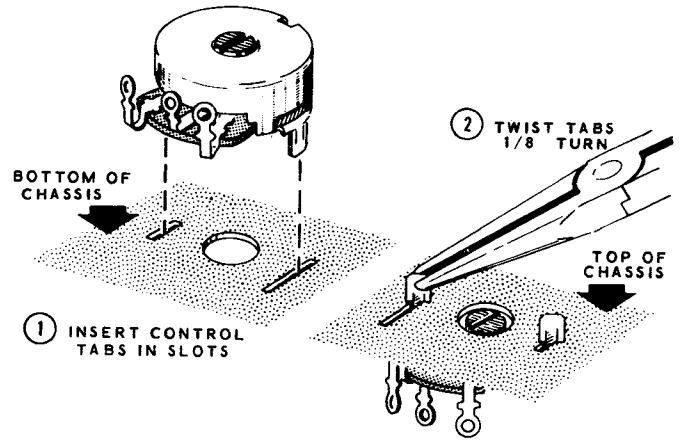

Detail 2-2K

- ( ) Referring to Detail 2-2K, install the three 10 KΩ controls (#10-57) at BB, BC, and BD. Insert the control tabs through the chassis and twist them 1/8 turn. Position each control as shown. Be sure the lugs of controls BB and BD do not touch the cover of control BC.

Refer to Detail 2-2L for the following steps.

- ( ) Mount the 2.1 kHz SSB crystal filter (#404-283) on the crystal filter mounting bracket at FL-1. Use two small #6 solder lugs, four #4 lockwashers, and two 4-40 nuts as shown in Detail 2-2L.

NOTE: If you have purchased the 400 Hz CW crystal filter, mount it to the crystal filter bracket at FL-2. Use #4 lockwashers and 4-40 nuts.

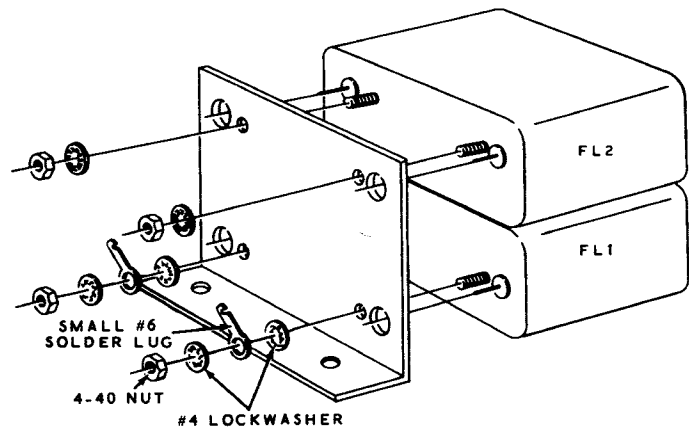

Detail 2-2L

- ( ) Refer to Detail 2-2M and mount the crystal filter mounting bracket at BU. Use 6-32 x 3/8" flat head hardware.

Refer to Detail 2-2N for the following steps.

- ( ) Locate the LMO (linear master oscillator) and remove the tube and tube shield. Set them aside until called for later.
- ( ) Mount the LMO on the top of the chassis, with the spade bolts through the slotted holes in the chassis as shown. Use #6 lockwashers and 6-32 nuts. Do not tighten the hardware at this time. Position the spade bolts of the LMO so they are centered in the slots in the chassis.
- ( ) Slide the circular dial (from package #100-450) on the shaft of the LMO. Place a ruler or other straight edge along the front of the chassis. Adjust the LMO so the circular dial is parallel to the front edge of the chassis. Now tighten the nuts that secure the LMO to the chassis. The end of the LMO tuning shaft should be approximately flush with the edge of the chassis.
- ( ) Remove the circular dial from the shaft of the LMO and return it to package #100-450.

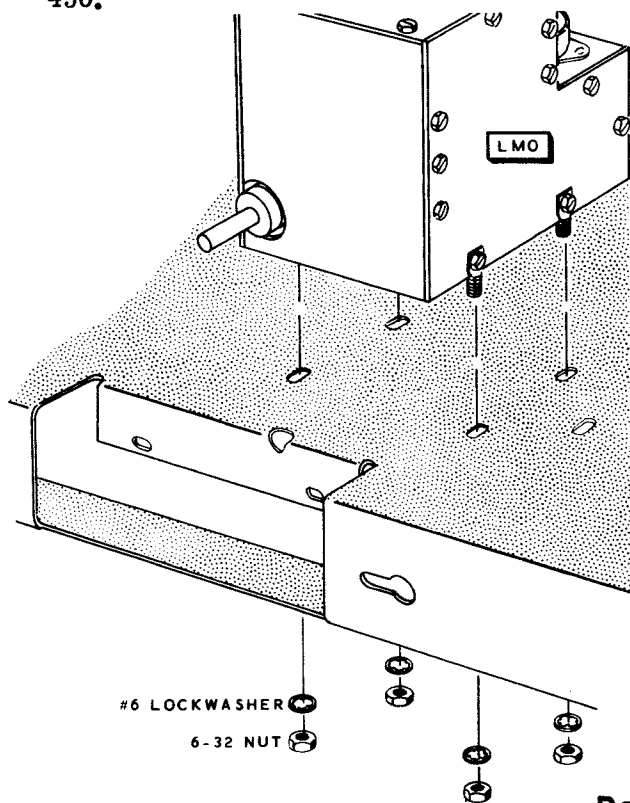

Detail 2-2N

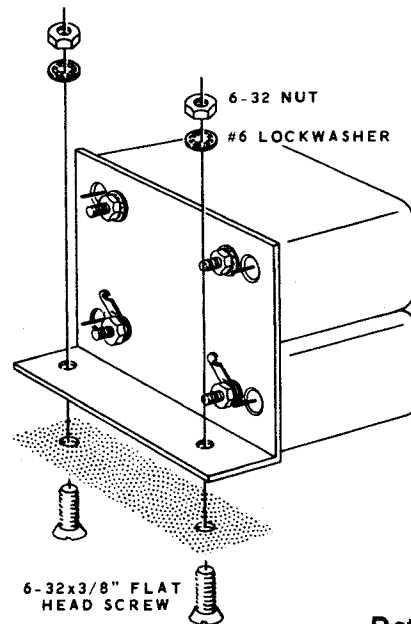

Detail 2-2M

Refer to Detail 2-2P for the following steps.

- ( ) Bend the three indicated lugs of the 3-section variable capacitor (#26-92) down as shown. The remaining three lugs should be left bent up.
- ( ) Mount this capacitor at DB on top of the chassis, with a 4-lug terminal strip at BK and a large #6 solder lug at BS on the bottom of the chassis. Use a 6-32 x 3/8" screw, two #6 lockwashers, a #6 flat washer, and a #6 fiber shoulder washer at BK. Position the terminal strip as shown. Use a 6-32 x 1/4" screw, large #6 solder lug, and #6 fiber shoulder washer, at BS. Then use a 6-32 x 1/4" screw, #6 lockwasher, and #6 fiber shoulder washer at the remaining hole.

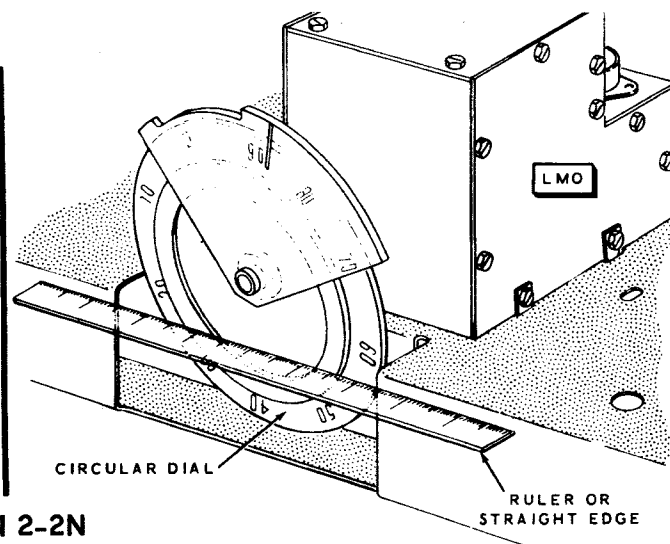

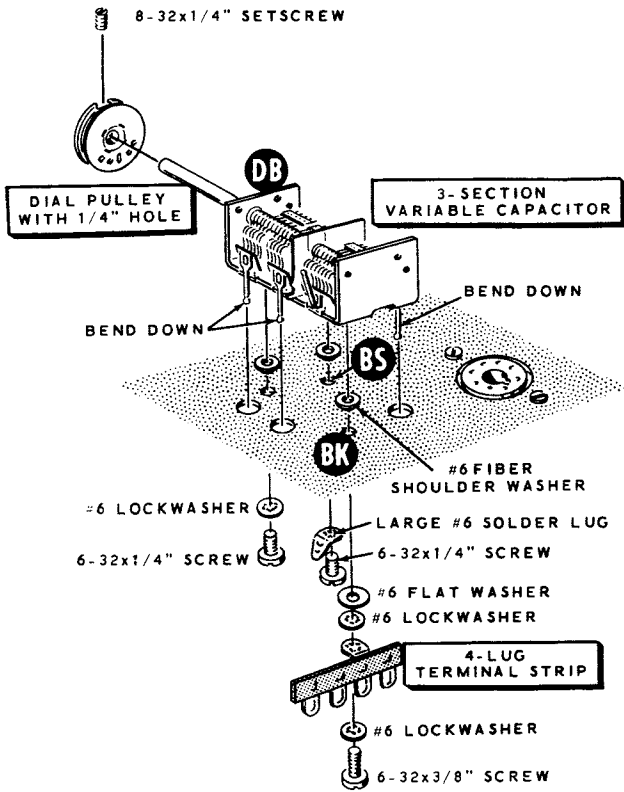

Detail 2-2P

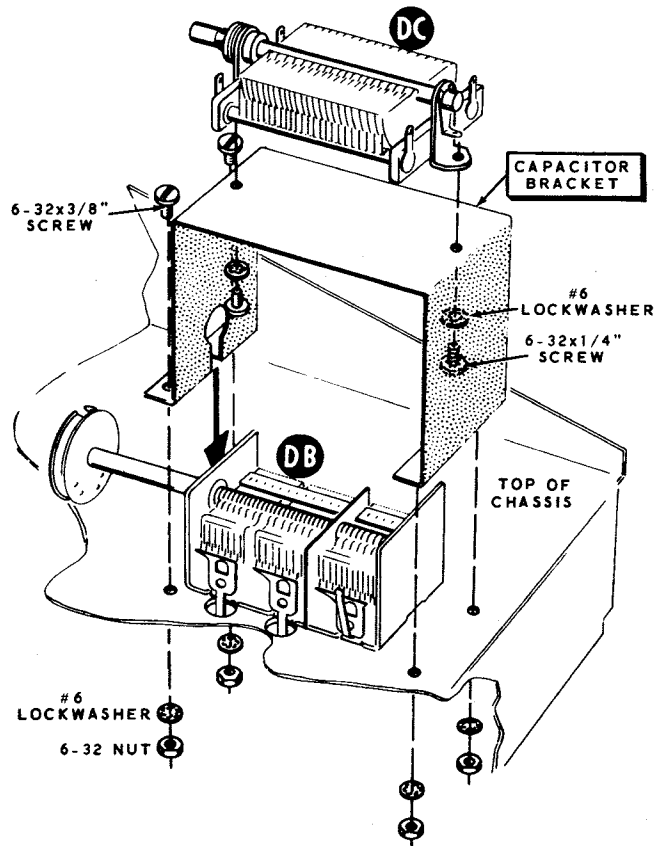

Detail 2-2Q

- ( ) Install the pulley with the 1/4" hole (#100-19) flush with the end of the shaft of capacitor DB. Use an 8-32 x 1/4" setscrew. Position the pulley as shown, with the plates fully meshed.

Refer to Detail 2-2Q for the following steps.

- ( ) Mount a 250 pf variable capacitor (#26-77) at DC on the capacitor bracket. Use 6-32 x 1/4" screws and #6 lockwashers.
- ( ) Mount capacitor DC and the capacitor bracket over capacitor DB on the chassis. Use 6-32 x 3/8" hardware.
- ( ) Refer to Detail 2-2R, then install RF choke (#45-41) at DA on top of the chassis, with a 3-lug miniature terminal strip at BM on the bottom of the chassis. Use a 6-32 x 3/8" screw, #6 lockwashers, and a 1/4" fiber flat washer. Position the terminal strip as shown with the bottom lug of the choke over grommet BL. Do not overtighten the screw, as the choke can be damaged.

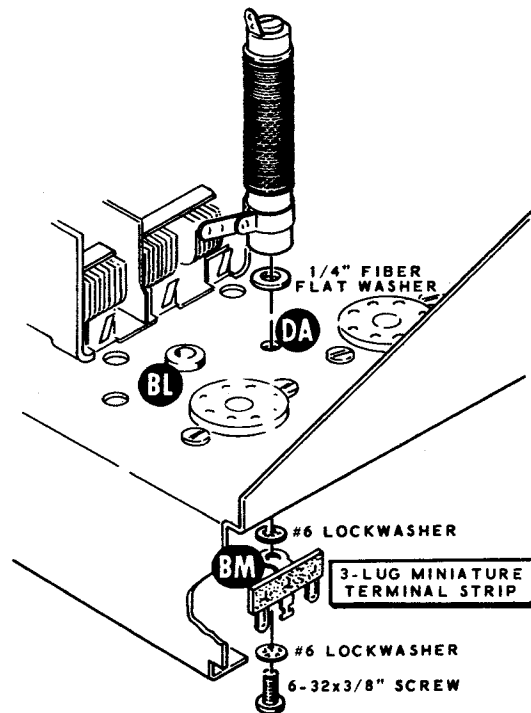

Detail 2-2R

Refer to Detail 2-2S for the following steps.

- ( ) Remove and discard the screws and flat washers from the top (small end) of the two standoff insulators.
- ( ) Install the standoff insulators with #6 fiber flat washers on the proper screws of the final tank coil (#40-548). Do not overtighten the insulators as they could easily be damaged.

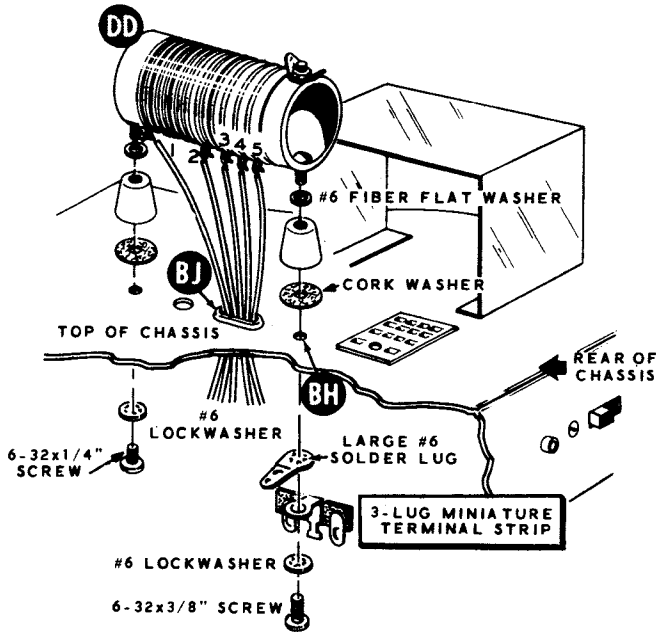

Detail 2-2S

**NOTE:** When a wire is called for in a step, use the small hookup wire of the indicated color, unless the large red wire is specified. Then cut the wire to the length given in the step, and remove 1/4" of insulation from each end. (After the insulation is removed from the ends of the large red wire, twist the small wire strands together and melt a small amount of solder on the exposed wire ends.)

Connect the following lengths of large red hookup wire to the lugs of the final tank coil. One end only of each wire will be connected at this time.

- ( ) 3-1/2" to lug 1 (S-1).
- ( ) 3-1/4" to lug 2 (S-1).

- ( ) 3" to lug 3 (S-1).
- ( ) 3-1/2" to lug 4 (S-1).
- ( ) 4" to lug 5 (S-1).
- ( ) Remove the screw, flat washer, and cork washer from the bottom of both standoff insulators. Discard the screws and flat washers.
- ( ) Mount final tank coil DD on the top of the chassis, with a 3-lug miniature terminal strip and a large #6 solder lug at BH on the bottom of the chassis. Use a 6-32 x 3/8" screw, a #6 lockwasher, and the cork washer furnished with the standoff insulator at BH. Use a 6-32 x 1/4" screw, #6 lockwasher, and the cork washer furnished with the standoff insulator at the front location. Position the coil as shown with its leads in proper sequence through grommet BJ.

Refer to Pictorial 2-2 (fold-out from Page 35) for the following steps.

- ( ) Referring to Detail 2-2T, mount the final shield. Use 6-32 x 3/8" hardware and #6 x 1/2" sheet metal screws.

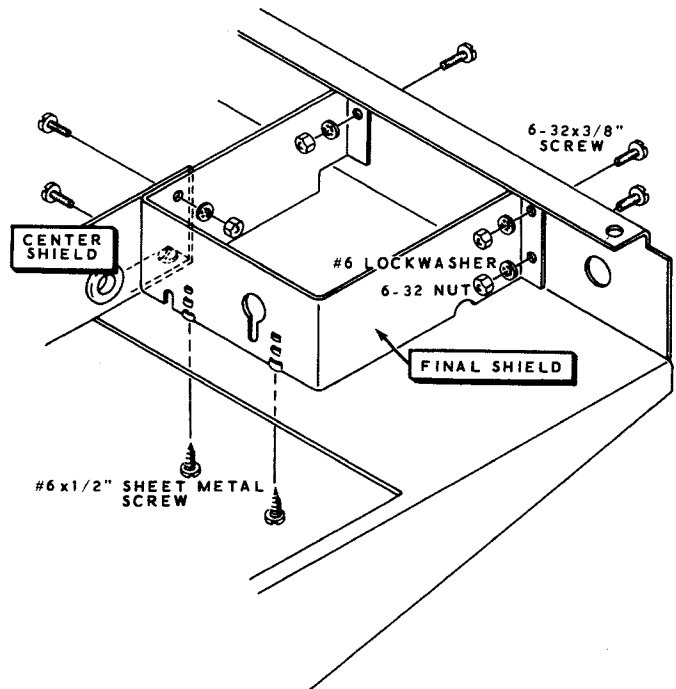

Detail 2-2T



( ) Now, tighten all the hardware of the circuit boards and center shield.

( ) Remove the 6-32 x 3/8" hardware from hole BZ at the front of the center shield.

Refer to Detail 2-2U for the following steps.

( ) Locate and disassemble the RF cage by removing the four screws. Retain these screws for later use.

( ) Mount the RF cage on the top of the chassis with six #6 x 1/2" sheet metal screws, with a large #6 solder lug at BF, a 6-lug terminal strip at EA, and a 4-lug terminal strip at BN on the bottom of the chassis. Position the solder lug and terminal strips as shown.

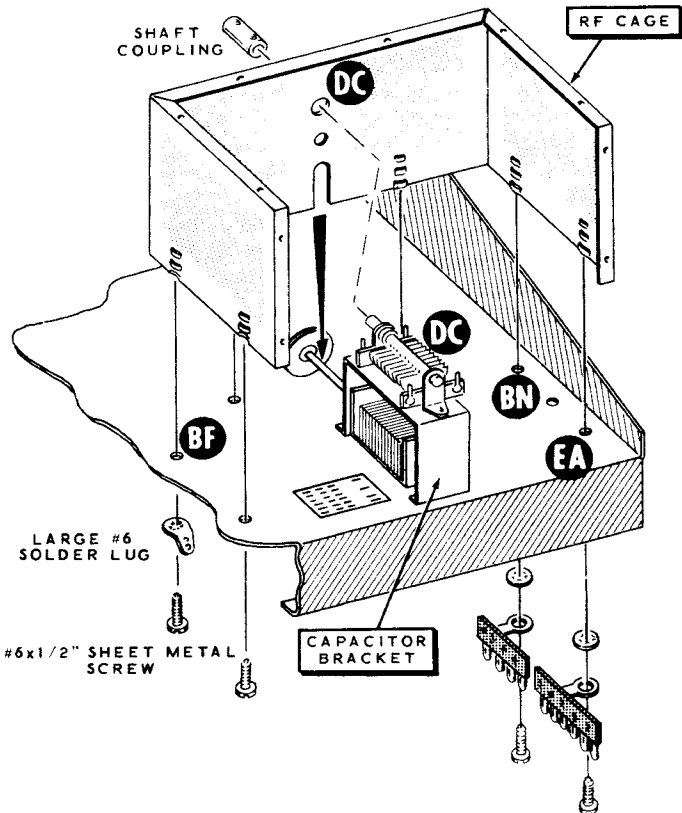

Detail 2-2U

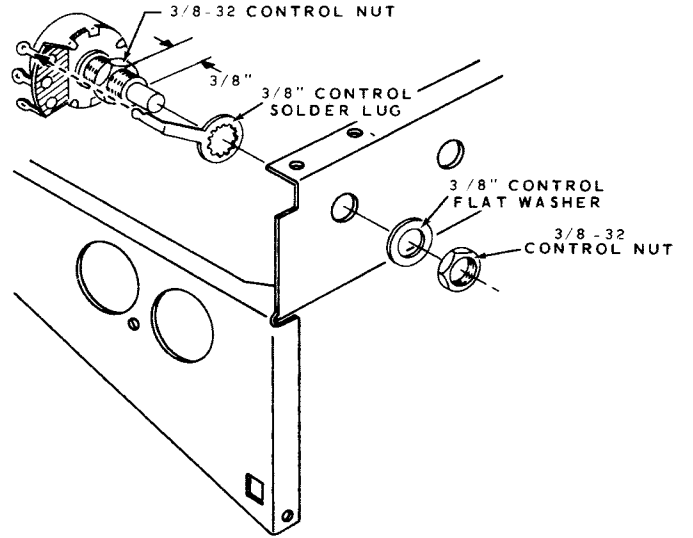

Detail 2-2V

( ) Temporarily position the shaft coupling on the shaft of variable capacitor DC to see that it does not rub in hole DC of the RF cage. If it does, loosen the capacitor bracket hardware and make the necessary adjustments. Retighten the hardware and remove the shaft coupling.

( ) Refer to Detail 2-2V and install a 500 KΩ control (#10-68) at R. Use a 3/8" control solder lug, a 3/8" control flat washer, and two 3/8-32 control nuts. Thread the first nut onto the control bushing so it is 3/8" from the front end of the bushing. Position the control and control solder lug as shown. Bend the solder lug against lug 1 of the control.

( ) Refer to Detail 2-2W and install the 4-lug jack at L. Use a 3/8" control flat washer and a 3/8-32 control nut. Position the jack as shown in Pictorial 2-2.

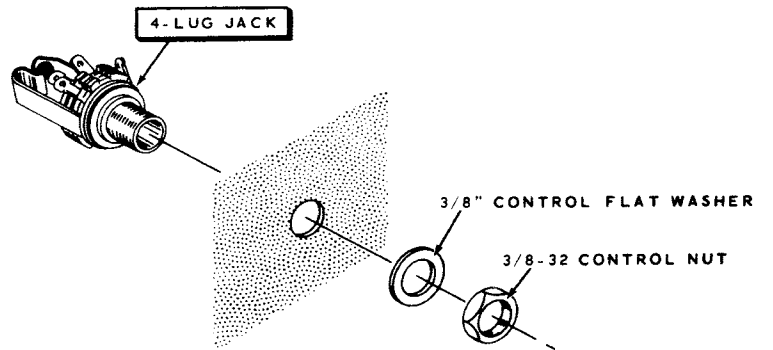

Detail 2-2W

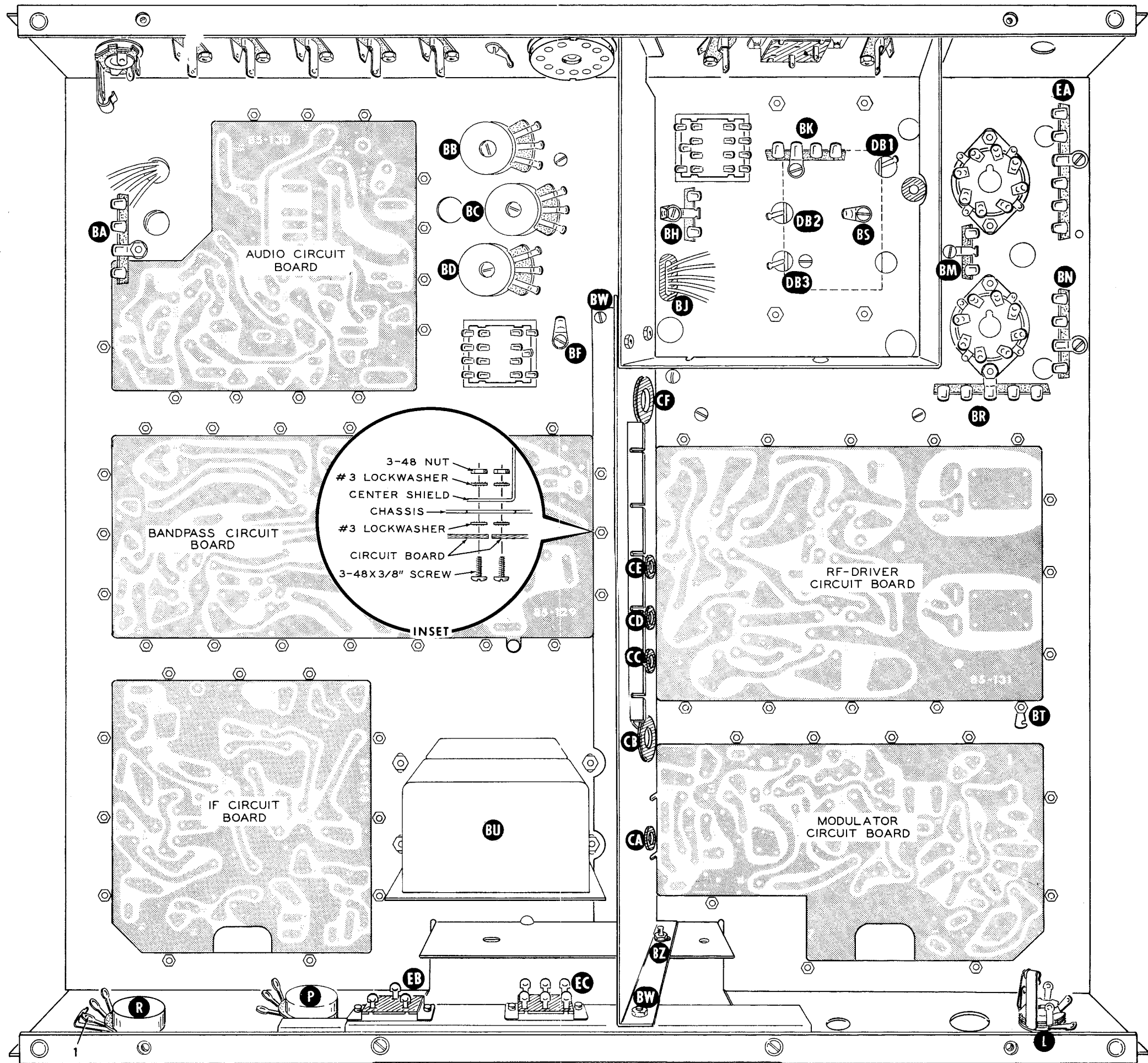

**PICTORIAL 2-2**

## HARNES WIRING

**NOTE:** Because of the many wires in the wire harness, it is not possible to show the hookup of every wire in one Pictorial. Therefore, the wires not connected in the first Pictorial will be connected in the second one.

Refer to Pictorial 3-1 for the following steps.

Locate the wire harness #134-121, and place it into the chassis as shown. Arrange the break-outs as directed in the following steps.

- ( ) Place a 1/2" rubber grommet over BO#17 (breakout #17) and pass BO#17 through notch CG in the final shield. Work the grommet into notch CG.
- ( ) Pass BO#18 through grommet CF and BO#20 and BO#21 through grommet CB in the center shield.
- ( ) At BO#19 pass the yellow and blue-white wires through grommet CE, the red-red-white wire through grommet CD, and the orange-yellow-white wire through grommet CC of the center shield.
- ( ) Position BO#22 and BO#23 around the front end of the center shield, and pass BO#23 through the cutout in the modulator circuit board. Be careful not to cut any wires when bending the wire harness around the center shield. The sharp edges should be covered with tape.
- ( ) Pass BO#1 through the cutout in the IF circuit board.
- ( ) Pass the orange-orange-white and gray-white wires from BO#8 through hole BY.

To get the best performance from your Transceiver, it should be wired neatly. All wires should be positioned down against the chassis wherever possible, and all components should be positioned as close as possible to the locations shown. Check periodically with the chassis photos at the rear of the Manual to see how the finished kit should appear.

Connect the wires from BO#2 to the IF circuit board as follows:

- ( ) Yellow to 12 (S-1).
- ( ) Green-white to 7 (S-1).
- ( ) Red to 10 (S-1).
- ( ) Red-white to 9 (S-1).

Connect the wires from BO#2 to control P as follows:

- ( ) Yellow-yellow-white to lug 3 (S-1).
- ( ) Violet-white to lug 1 (S-1).

Connect the wires from BO#3 to the IF circuit board as follows:

- ( ) Black to 2 (S-1).
- ( ) Black-white to 3 (S-1).
- ( ) Red-red-white to 4 (S-1).
- ( ) Small brown-white to 6 (S-1).
- ( ) Large brown-white to 6 (S-1).
- ( ) Connect the three red wires from BO#4 to 1 on the IF circuit board (S-3).
- ( ) Connect the blue-white wire from BO#5 to 5 on the IF circuit board (S-1).

Connect the wires from BO#6 to the IF circuit board as follows:

- ( ) Both red-red-white to 11 (S-2).
- ( ) Brown to 8 (S-1).
- ( ) Connect both yellow wires from BO#7 to 13 on the IF circuit board (S-2).

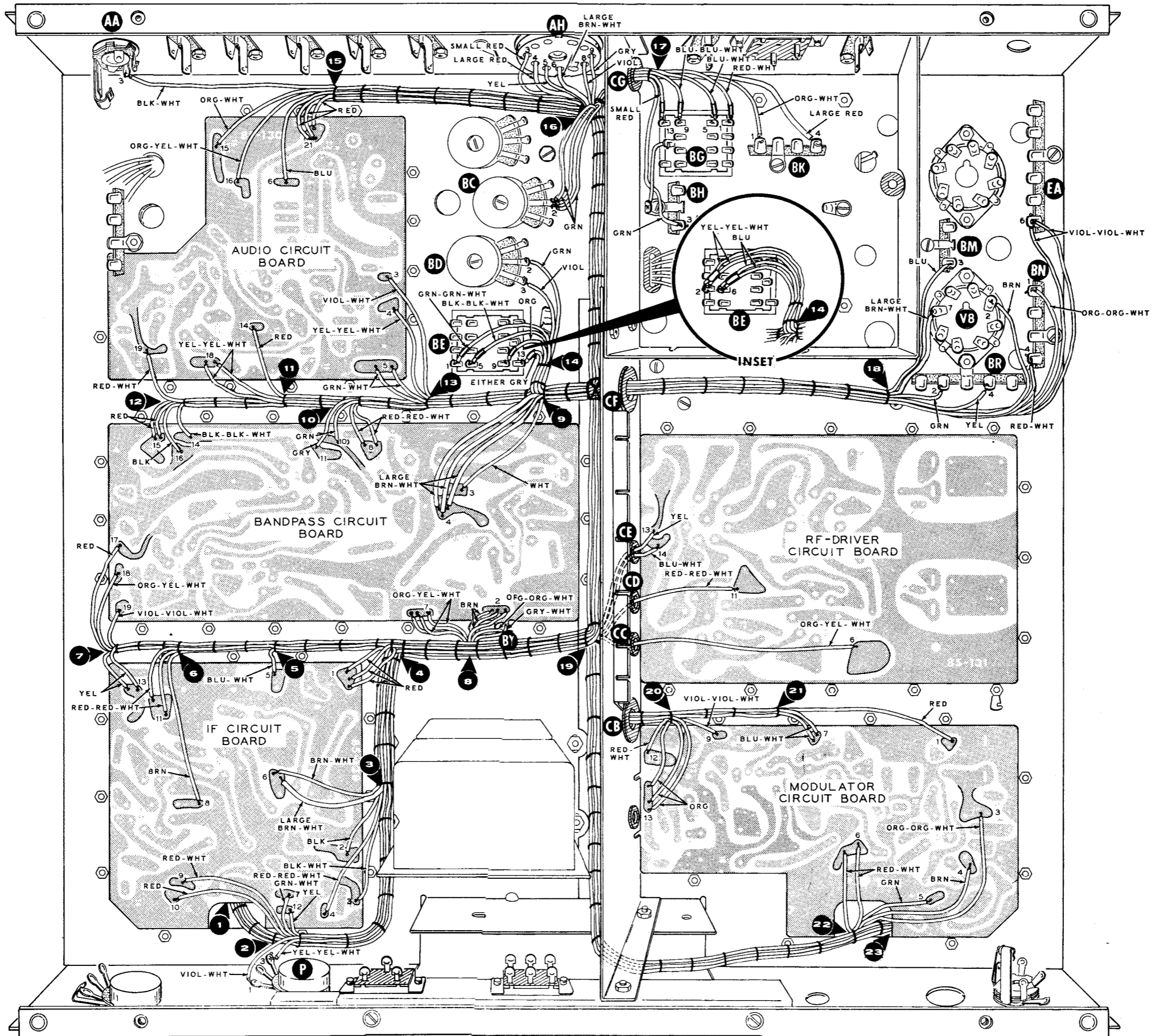

PICTORIAL 3-1

Connect the wires from BO#7 to the bandpass circuit board as follows:

- ( ) Violet-violet-white to 19 (S-1).
- ( ) Orange-yellow-white to 18 (S-1).
- ( ) Red to 17 (S-1).

Connect the wires from BO#8 to the bandpass circuit board as follows:

- ( ) All three orange-yellow-white to 7 (S-3).
- ( ) All three brown to 2 (S-3).

Connect the wires from BO#9 to the bandpass circuit board as follows:

- ( ) Small white to 3 (S-1).
- ( ) Three large brown-white to 4 (S-3).

Connect the wires from BO#10 to the bandpass circuit board as follows:

- ( ) Both red-red-white to 8 (S-2).
- ( ) Green to 10 (S-1).
- ( ) Gray to 11 (S-1)

Connect the wires from BO#11 to the audio circuit board as follows:

- ( ) Both yellow-yellow-white to 18 (S-2). (The number 18 on the foil is partially covered.)
- ( ) Red to 14 (S-1).

Connect the wires from BO#12 to the bandpass circuit board as follows:

- ( ) Black-black-white to 14 (S-1).
- ( ) Both red to 15 (S-2).
- ( ) Black to 16 (S-1).
- ( ) Connect the red-white wire from BO#12 to 19 on the audio circuit board (S-1).

Connect the wires from BO#13 to the audio circuit board as follows:

- ( ) Both green-white to 5 (S-2).
- ( ) Yellow-yellow-white to 4 (S-1).
- ( ) Violet-white to 3 (S-1).
- ( ) Bend BO#14 so its wires point straight up from the chassis.

NOTE: Place a 1/2" length of sleeving on a wire, or wires, before making a connection to one of the lugs of the relay socket. After the connection has cooled, push the sleeving down over the relay socket lug. See Detail 3-1A. Use the small sleeving for single wires. Where two wires connect to the same lug of the relay socket, place both wires in a single length of large sleeving. Be careful not to overheat the large sleeving.

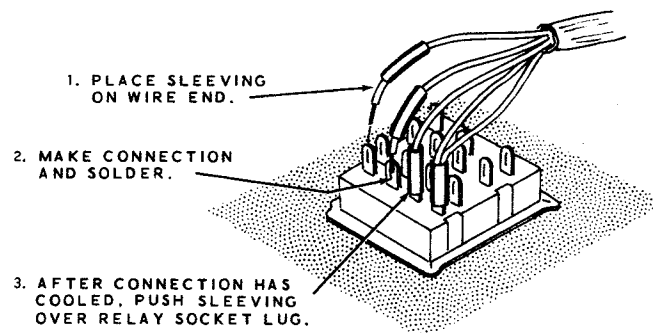

**Detail 3-1A**

Connect the wires from BO#14 to relay socket BE as follows:

- ( ) Either gray to lug 13 (S-1).
- ( ) Orange to lug 9 (S-1).
- ( ) Black-black-white to lug 5 (S-1).
- ( ) Green-green-white to lug 1 (S-1). Be sure not to use the green-white wire for this connection.

Referring to the inset drawing on Pictorial 3-1, connect the wires from BO#14 to relay socket BE as follows:

- ( ) Both blue to lug 6 (S-2).
- ( ) Both yellow-yellow-white to lug 2 (S-2).

Connect the wires from BO#14 to control BD as follows:

- ( ) Violet to lug 3 (S-1).
- ( ) Green to lug 2 (S-1).
- ( ) Connect all three green wires from BO#16 to lug 2 of control BC (S-3).

**NOTE:** When connecting wires to 11-pin plug AH, remove 1/2" of insulation from the wire end. See Detail 3-1B. After the wires are soldered to the plug pins, clip off the excess wire ends. Position the wires as shown.

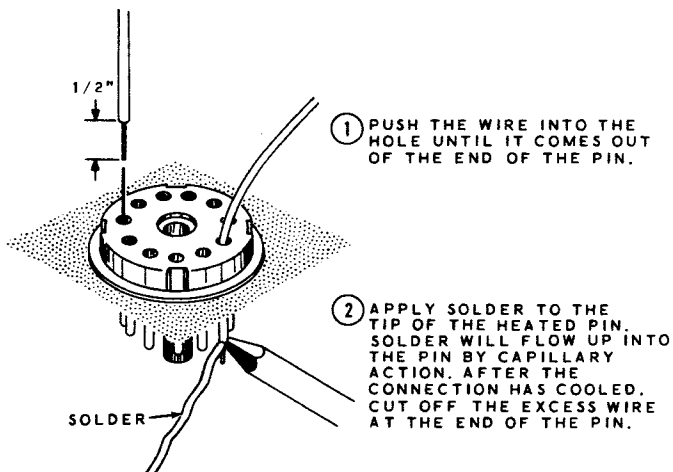

**Detail 3-1B**

Connect the wires from BO#16 to 11-pin plug AH as follows:

- ( ) Large brown-white to pin 6 (S-1).
- ( ) Yellow to pin 5 (S-1).
- ( ) Large red to pin 4 (S-1).
- ( ) Small red to pin 3 (S-1).

- ( ) Violet to pin 8 (S-1). **NOTE:** Pin 7 will be connected later. Be careful not to pull the violet wire out of the wiring harness.

- ( ) Gray to pin 9 (S-1).
- ( ) Connect the black-white wire from BO#15 to lug 3 of jack AA (NS).

Connect the wires from BO#15 to the audio circuit board as follows:

- ( ) Orange-white to 15 (S-1).
- ( ) Orange-yellow-white to 16 (S-1).
- ( ) Blue to 6 (S-1).
- ( ) All three red to 21 (S-3).
- ( ) Connect the green wire from BO#17 to lug 3 of terminal strip BH (NS).

**NOTE:** When bare wire is called for in a step, use the small bare wire unless the large bare wire is specified.

- ( ) Connect a 1-3/4" bare wire from the unmarked lug of relay socket BG (S-1) to the solder lug at BH (NS).

Connect the wires from BO#17 to relay socket BG as follows. Be sure to use sleeving.

- ( ) Small red to lug 13 (S-1).
- ( ) Blue-blue-white to lug 9 (S-1).
- ( ) Blue-white to lug 5 (S-1).
- ( ) Red-white to lug 1 (S-1).
- ( ) Position these wires down against the chassis behind the relay socket.

Connect the wires from BO#17 to terminal strip BK as follows:

- ( ) Orange-white to lug 1 (NS).
- ( ) Large red to lug 4 (NS).
- ( ) Connect the blue wire from BO#18 to lug 3 of terminal strip BM (NS).

- ( ) Connect the large brown-white wire from BO#18 to lug 7 of tube socket V8 (NS).

Connect the wires from BO#18 to terminal strip BR as follows:

- ( ) Green to lug 2 (NS).
- ( ) Yellow to lug 4 (NS).
- ( ) Connect the brown wire from BO#18 to lug 2 of tube socket V8 (NS).

Connect the wires from BO#18 to terminal strip BN as follows:

- ( ) Red-white to lug 4 (NS).
- ( ) Orange-orange-white to lug 1 (NS).
- ( ) Connect both violet-violet-white wires from BO#18 to 6 of terminal strip EA (NS).

Connect the wires from BO#19 to the RF-driver circuit board as follows:

- ( ) Yellow to 13 (S-1).
- ( ) Blue-white to 14 (S-1).
- ( ) Red-red-white to 11 (S-1).
- ( ) Orange-yellow-white to 6 (S-1).

Connect the wires from BO#20 to the modulator circuit board as follows:

- ( ) Red-white to 12 (S-1).
- ( ) All three orange to 13 (S-3).
- ( ) Violet-violet-white to 9 (S-1).

Connect the wires from BO#21 to the modulator circuit board as follows:

- ( ) Both blue-white to 7 (S-2).
- ( ) Red to 1 (S-1).

Connect the wires from BO#22 to the modulator circuit board as follows:

- ( ) Both red-white to 6 (S-2).

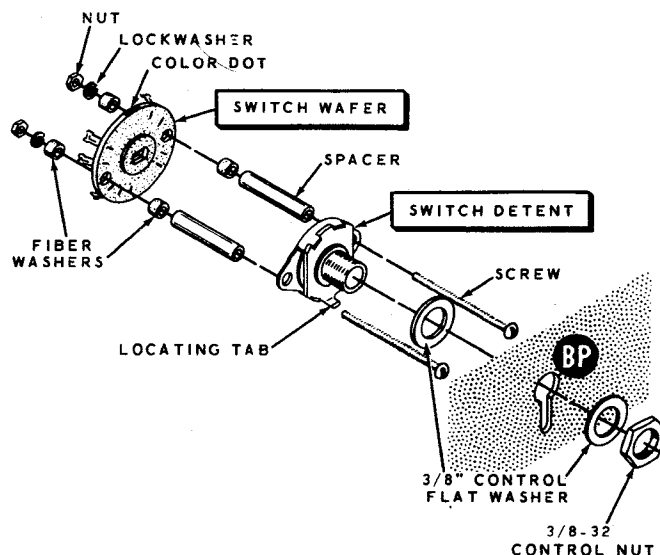

Detail 3-2A

- ( ) Green to 5 (S-1).
- ( ) Brown to 4 (S-1).
- ( ) Orange-orange-white to 3 (S-1).

Refer to Pictorial 3-2 (fold-out from Page 41) and Detail 3-2A for the following steps.

NOTE: In the following step, the hardware supplied with the switch wafer may be different from the hardware shown in the Detail. Use only the hardware supplied when assembling the switch wafer to the switch detent.

- ( ) Locate rotary switch wafer #63-395. Remove the hardware from the switch wafer carefully and observe the sequence in which the hardware was removed.
- ( ) Assemble the rotary switch wafer to the rotary switch detent using the hardware supplied with the switch wafer. Make sure the lugs of the switch wafer are positioned as shown in the Detail; note their position with respect to the locating tab on the switch detent.
- ( ) Mount the switch assembly at BP on the final shield. Use two 3/8" control flat washers and a 3/8-32 control nut. Position the locating tab on the switch detent in the slot in the final shield.

Refer to Pictorial 3-2 (fold-out from Page 41) for the following steps.

- ( ) Connect a 1-3/4" black wire from lug 3 of control R (S-1) to 14 on the IF circuit board (S-1).

Connect the wires from BO#9 to the bandpass circuit board as follows:

- ( ) Either red to 6 (S-1).
- ( ) Other red to 5 (S-1).

Connect the wires from BO#10 to the bandpass circuit board as follows:

- ( ) Both brown to 12 (S-2).
- ( ) Yellow-yellow-white to 9 (S-1).

Connect the wires from BO#11 to the audio circuit board as follows:

- ( ) Both brown to 13 (S-2). Place both wires in the same hole.
- ( ) Small brown-white and large brown-white to 12 (S-2).
- ( ) Connect the brown-white wire from BO#12 to 13 on the bandpass circuit board (S-1).
- ( ) Connect both brown wires from BO#12 to the single hole at 17 on the audio circuit board (S-2).

Connect the wires from BO#13 to the audio circuit board as follows:

- ( ) Gray to 2 (S-1).
- ( ) Orange-white to 1 (S-1).

Connect the wires from BO#15 to the audio circuit board as follows:

- ( ) Orange to 22 (S-1).
- ( ) Green-white to 8 (S-1).
- ( ) Yellow-white to 9 (S-1).
- ( ) Violet to 10 (S-1).
- ( ) Large brown-white to 12 (S-1). Solder this end of the wire directly to the foil. There is no hole at this location.

Connect the output transformer leads as follows:

- ( ) Black to lug 2 of terminal strip BA (NS).
- ( ) Green to lug 3 of terminal strip BA (NS).
- ( ) White to lug 1 of terminal strip BA (NS).
- ( ) Connect a 10" black wire from lug 1 of terminal strip BA (NS) to lug 3 of control BB (S-1).
- ( ) Connect a 5" black wire from lug 1 of control BC (S-1) to 7 on the audio circuit board (S-1). Position the wire as shown.

NOTE: Where a lead or wire passes through a connection and then goes to another point, as in the next step, it will count as two wires in the soldering instructions (S-2), one entering and one leaving the connection.

- ( ) Connect a 3-1/2" bare wire from pin 7 of plug AH (S-1) through solder lug AG (NS) to lug 1 of control BB (NS). Be sure that this wire, when soldered, does not touch and melt the insulation of other wires.
- ( ) Connect a 1-3/4" bare wire from pin 2 of plug AH (S-1) to solder lug AG (S-3).
- ( ) Connect a 1-1/4" bare wire through the unmarked lug (S-2) to lug 10 (S-1) of relay socket BE. Connect the other end to solder lug BF (NS).
- ( ) Connect a 4700  $\Omega$  (yellow-violet-red) resistor from lug 3 of control BC (S-1) to solder lug BF (S-2).

Connect the wires from BO#14 to relay socket BE as follows:

- ( ) Orange-white to lug 11 (S-1).
- ( ) Orange-orange-white to lug 7 (S-1).
- ( ) Both red-red-white to lug 3 (S-2).

Referring to the inset drawing on Pictorial 3-2, connect the wires from BO#14 to relay socket BE as follows:

- ( ) Gray to lug 14 (S-1).
- ( ) Green-white to lug 12 (S-1).
- ( ) Both violet-violet-white to lug 8 (S-2).
- ( ) Both blue-white to lug 4 (S-2).



Connect the wires from BO#16 to plug AH as follows:

- ( ) Gray-white to pin 10 (S-1).
- ( ) Violet-white to pin 11 (S-1).
- ( ) Yellow-yellow-white to pin 1 (S-1).

Connect the wires from BO#17 to relay socket BG as follows:

- ( ) Yellow to lug 10 (S-1).
- ( ) Violet-white to lug 6 (S-1).
- ( ) Violet to lug 2 (S-1).
- ( ) Gray to lug 14 (NS). Do not use sleeving on this wire.
- ( ) Bend lug 4 of relay socket BG down against the socket as shown.
- ( ) Connect a 2-3/8" large bare wire from lug 1 of phono socket AL (S-1), against lug 1 of switch AK (S-2), to lug 3 of relay socket BG (S-1).
- ( ) Pass one end of a 2-3/4" large bare wire through lug 10 of switch BP (S-2) to lug DB3 (NS). Position the other end of this wire against DB2 (S-2) to lug 8 of relay socket BG (NS). Be careful not to damage the switch wafer.

Connect the large red wires extending from grommet BJ as follows:

- ( ) Wire coming from lug 1 of final tank coil DD (lug nearest the front of the chassis) to variable capacitor lug DB3 (S-2).
- ( ) Wire from lug 2 of final tank coil to lug 11 of switch BP (S-1).
- ( ) Wire from lug 3 of final tank coil to lug 12 of switch BP (S-1).
- ( ) Wire from lug 4 of final tank coil to lug 1 of switch BP (S-1).

( ) Wire from lug 5 of final tank coil to lug 2 of switch BP (S-1).

( ) Connect one end of a 2-1/2" large red wire to lug 4 of terminal strip BK (NS). Pass the other end of this wire through grommet BL for connection later.

( ) Connect a 3-1/2" brown wire from lug 2 of tube socket V9 (S-1) to lug 2 of tube socket V8 (NS).

( ) Connect a 4-1/2" white wire from lug 7 of tube socket V8 (NS) to 8 on the RF-driver circuit board (S-1).

( ) Connect a 6-1/2" brown wire from lug 2 of tube socket V8 (NS) to 10 on the RF-driver circuit board (S-1).

( ) Connect a 5-1/2" white wire from lug 1 of terminal strip BN (NS) to 5 on the RF-driver circuit board (S-1).

( ) Connect a 2-1/2" white wire from lug 1 of terminal strip BN (NS) to lug 1 of terminal strip BM (NS).

( ) Connect a 2-3/4" black wire from lug 2 of terminal strip BN (NS) to lug 5 of terminal strip EA (NS).

( ) Connect a 2" black wire between lugs 6 (NS) and 4 (NS) of terminal strip EA.

( ) Connect one end of a 5" black wire to 1 on the modulator circuit board (S-1). The other end of the wire will be connected later.

Connect the wires from BO#20 to the modulator circuit board as follows:

- ( ) Brown-white to 11 (S-1).
- ( ) Brown to 10 (S-1).

Connect the wires from BO#21 to the modulator circuit board as follows:

- ( ) Brown to 8 (S-1).
- ( ) Both yellow-white to 2 (S-2).

NOTE: The orange wire at BO#21 and the two black wires at BO#22 will be connected later.

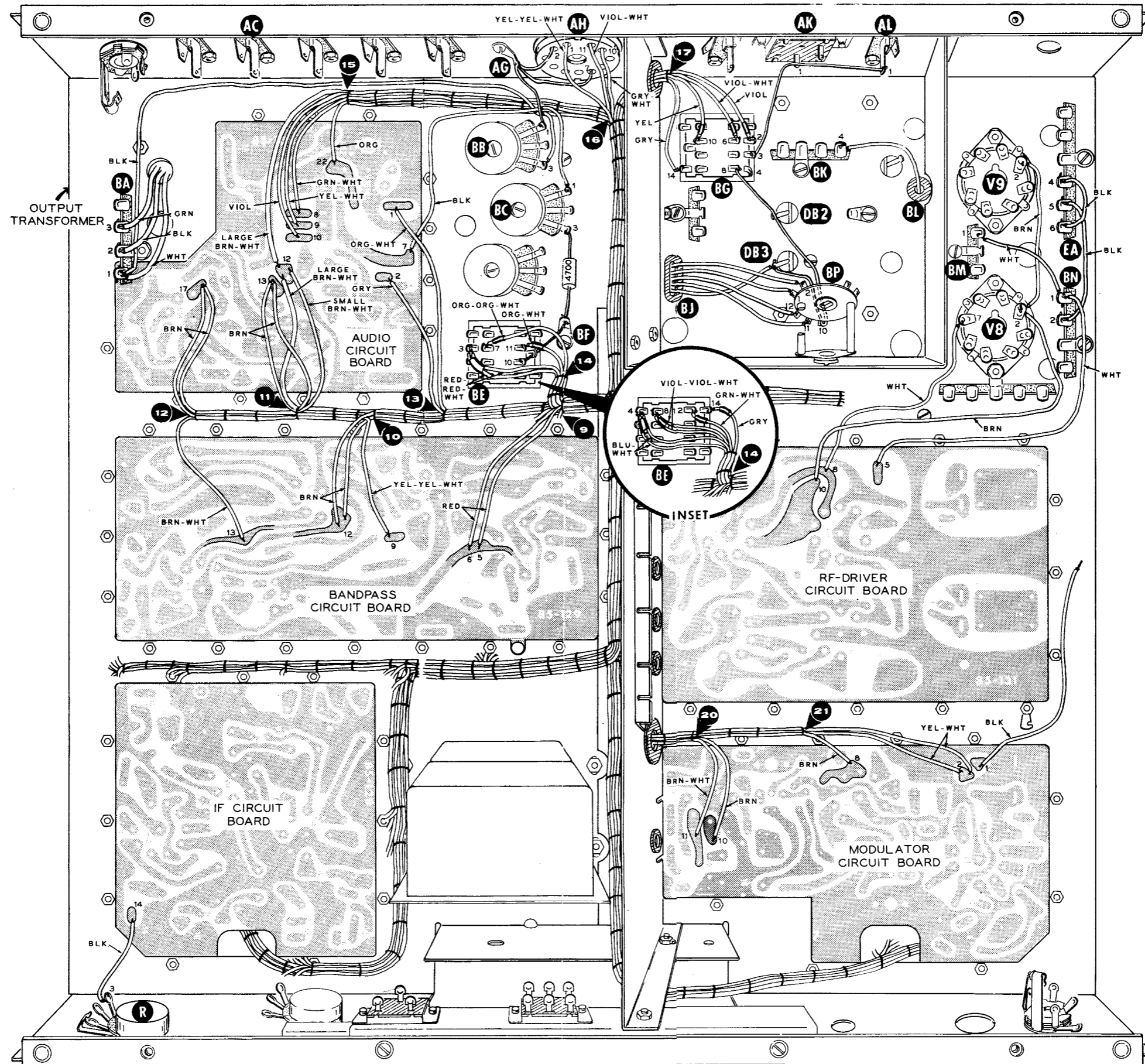

PICTORIAL 3-2

## COAXIAL CABLE HARNESS WIRING

**CAUTION:** The insulation on the inner lead of a coaxial cable melts quite easily, therefore the connections should be soldered as quickly as possible to prevent these cables from shorting. When soldering the shields, it is advisable to use a pair of long-nose pliers as a heat sink. Grip the shield between the connection and the cable. This will prevent the heat from reaching the insulation of the inner lead. A rubber band around the handles of the pliers will keep them in place to free both hands for soldering.

- ( ) Locate the coaxial cable harness (#134-122). Tightly twist together the small wire strands of each of the shields and each of the inner leads for each of the cables. Then melt a small amount of solder on the extreme end of each shield and inner lead. Use only enough solder to keep the small strands from untwisting. Too much solder will prevent the exposed ends of the cables from fitting into the holes of the circuit boards.

**NOTE:** Some of the cables are color coded with a piece of colored tape or paint. The cables will be called out by their color. Those cables not having any color identification will be referred to as black cables.

Refer to Pictorial 3-3 for the following steps.

Install the coaxial cable harness in the chassis as shown, and as directed in the following steps.

- ( ) Pass the violet cable from BO#8 through grommet CF, the red cable from BO#9 through grommet CC, and both cables from BO#10 through grommet CB in the center shield.
- ( ) Position BO#11 and BO#12 around the end of the center shield and pass the cables from BO#12 through the cutout in the modulator circuit board.
- ( ) Position the cables from BO#1 through the cutout in the IF circuit board.

- ( ) Connect the inner lead of the red cable from BO#2 to lug 2 of control R (S-1). Connect the shield of this cable to the control solder lug at control R (S-1). Be sure the solder lug was soldered to lug 1 of control R.
- ( ) Connect the inner lead of the blue cable from BO#3 to A (S-1), and connect the shield to the hole in the adjacent foil (S-1) on the IF circuit board.
- ( ) Connect the inner lead of the black cable from BO#4 to B (S-1) and connect the shield to the hole in the adjacent foil (S-1) on the IF circuit board.

Connect the cables from BO#3 to the bandpass circuit board as follows:

- ( ) Violet: inner lead to G (S-1) and the shield to the hole in the adjacent foil (S-1).
- ( ) Orange: inner lead to F (S-1) and the shield to the hole in the adjacent foil (S-1).

Connect the cables from BO#4 to the bandpass circuit board as follows:

- ( ) Blue: inner lead to J (S-1) and the shield to the hole in the adjacent foil (S-1).
- ( ) White: inner lead to H (S-1) and the shield to the hole in the adjacent foil (S-1).
- ( ) Prepare the ends of a 5-1/2" length of coaxial cable as shown in Detail 3-3A.
- ( ) At one end of the prepared cable, connect the inner lead to A (S-1) and the shield to the adjacent foil (S-1) on the bandpass circuit board. Pass the other end of this cable through grommet CF in the center shield for connection later. Position the cable between the two harnesses.
- ( ) Connect the inner lead of the red cable from BO#5 to B (S-1) and connect the shield to the hole in the adjacent foil (S-1) on the bandpass circuit board. Do not use hole #1 in the foil.

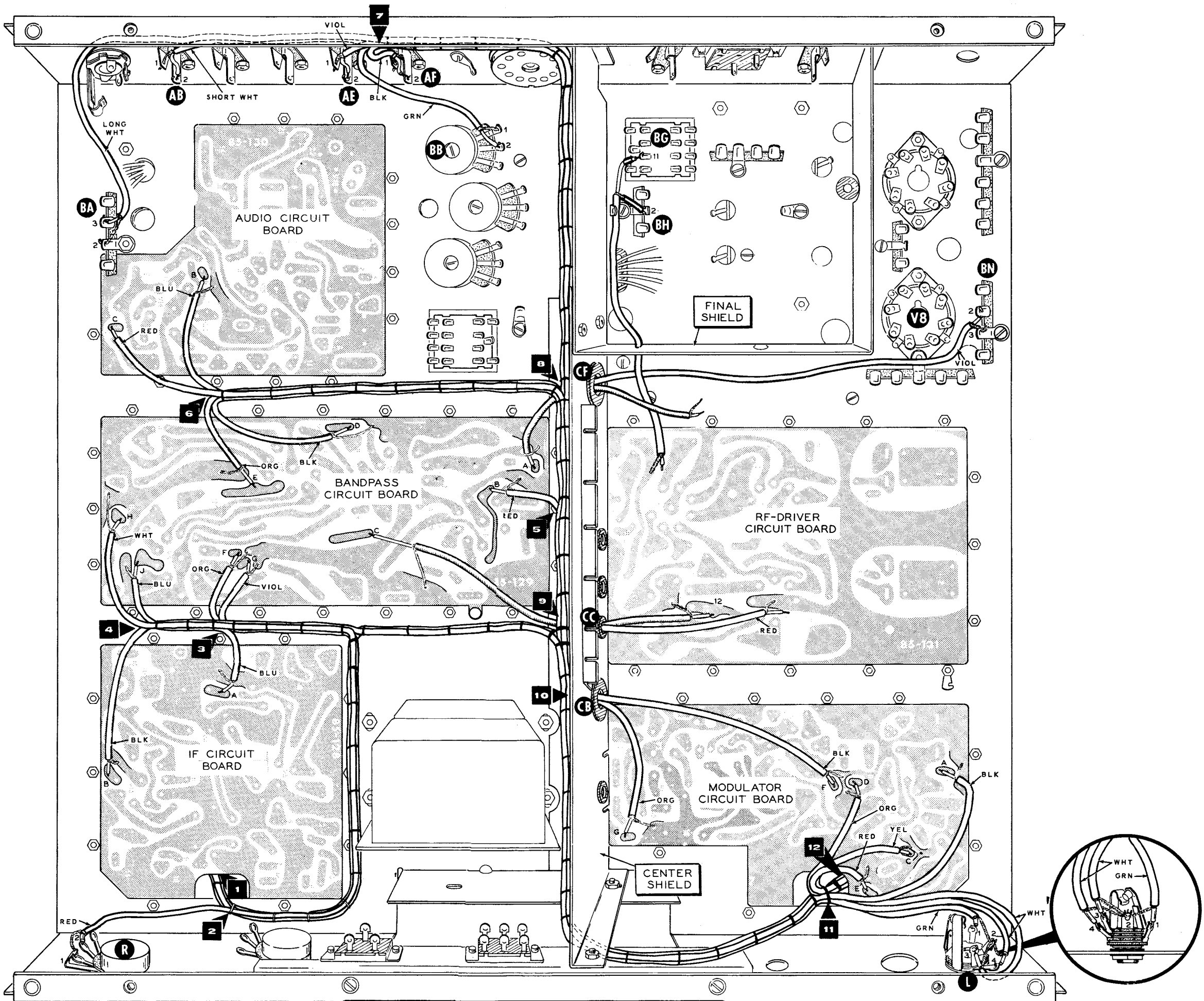

**PICTORIAL 3-3**

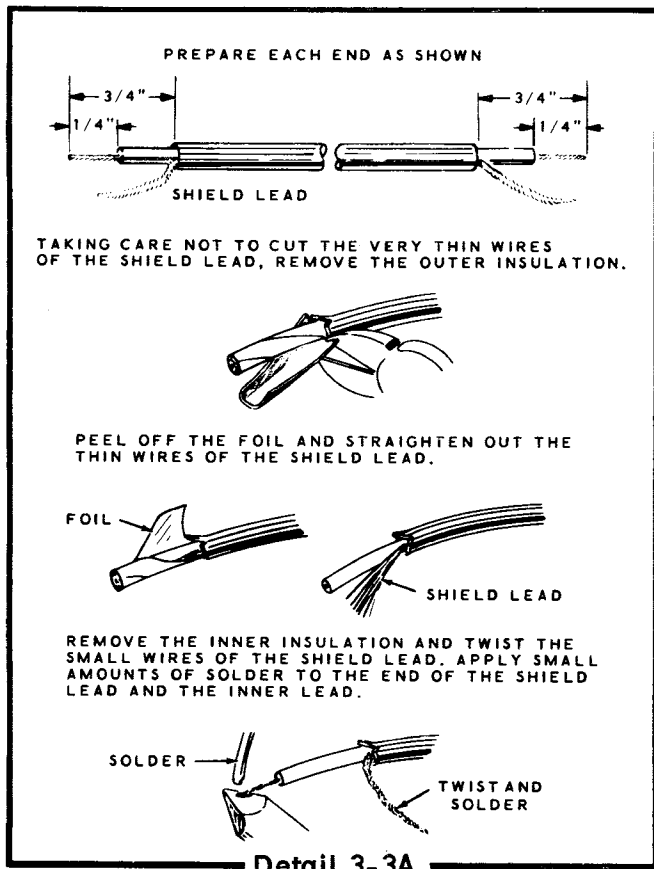

Connect the cables from BO#7 as follows:

- ( ) Black: inner lead to lug 2 (S-1) and the shield to lug 1 (S-1) of phono socket AF.
- ( ) Green: inner lead to lug 2 (S-1) and the shield to lug 1 (S-2) of control BB.
- ( ) Violet: inner lead to lug 2 (S-1) and the shield to lug 1 (S-1) of phono socket AE.
- ( ) Short white: inner lead to lug 2 (S-1) and the shield to lug 1 (S-1) of phono socket AB.
- ( ) Long white: inner lead to lug 3 (S-2) and the shield to lug 2 (NS) of terminal strip BA.
- ( ) Prepare the ends of a 7" length of coaxial cable as shown in Detail 3-3B.

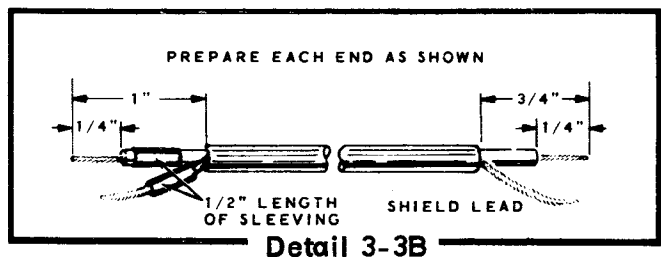

- ( ) Place a 1/2" length of sleeving over the longer inner lead and the longer shield of this cable. Connect this inner lead to lug 11 of relay socket BG (S-1), and connect the shield to lug 2 of terminal strip BH (NS). Now, push the sleeving over the relay socket lug.
- ( ) Pass the other end of this 7" cable through the notch in the final shield for connection later.
- ( ) Connect the inner lead of the violet cable from BO#8 to lug 2 (NS) and the shield lead to lug 3 (NS) of terminal strip BN.
- ( ) Connect the shield of the red cable from BO#9 to the foil at the center pin of tube socket V6 (S-1). Keep the connection close to the circuit board to permit the mounting of the switch shield later. The inner lead of this cable will be connected later.

Connect the cables from BO#6 to the bandpass circuit board as follows:

- ( ) Black: inner lead to D (S-1) and the shield to the adjacent foil (S-1).
- ( ) Orange: inner lead to E (S-1) and the shield to the adjacent foil (S-1).

Connect the cables from BO#6 to the audio circuit board as follows:

- ( ) Red: inner lead to C (S-1). Cut off the shield; it is not used.
- ( ) Blue: inner lead to B (S-1) and the shield to the adjacent foil (S-1).

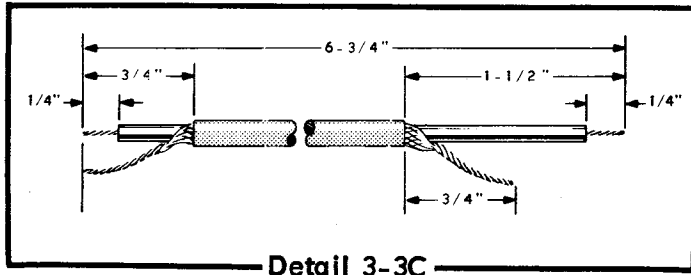

- ( ) Prepare the end of a 6-3/4" length of coaxial cable as shown in Detail 3-3C.
- ( ) At the end of this cable with the longer inner lead, connect the inner lead to C (S-1) and the shield to the indicated foil (S-1) on the bandpass circuit board.
- ( ) Pass the other end of this cable between the cable harnesses and through grommet CC in the center shield. Connect the inner lead to 12 on the RF-driver circuit board (S-1), and connect the shield to the center pin of tube socket V11 (S-1). Keep the connection at the center pin close to the circuit board to permit the mounting of the switch shield later.

Connect the cables from BO#10 to the modulator circuit board as follows:

- ( ) Orange: inner lead to G (S-1) and the shield to the adjacent foil (S-1).
- ( ) Black: inner lead to F (S-1) and the shield to the adjacent foil (S-1).

Connect the cables from BO#11 to the modulator circuit board as follows:

- ( ) Red: inner lead to E (S-1) and the shield to the adjacent foil (S-1).
- ( ) Yellow: inner lead to C (S-1) and the shield to the adjacent foil (S-1).

- ( ) Orange: inner lead to D (S-1) and the shield to the adjacent foil (S-1).
- ( ) Black: inner lead to A (S-1) and the shield to the adjacent foil (S-1).

Connect the cables from BO#11 to jack L as follows:

- ( ) Green: inner lead to lug 1 (S-1) and the shield to lug 2 (NS).
- ( ) Either white: inner lead to lug 4 (S-1) and the shield to lug 2 (NS).
- ( ) Other white: inner lead to lug 3 (S-1) and the shield to lug 2 (S-3).

The coaxial cable harness may be tied with string to the wire harness to hold it more firmly in place.

## COMPONENT MOUNTING-CHASSIS BOTTOM

Refer to Pictorial 3-4 (fold-out from Page 47) for the following steps.

- ( ) Connect the lead from the cathode end (color band, color dot, or colored end) of a silicon diode (#57-27) to lug 2 of control P (S-1). Connect the other lead to 12 on the IF circuit board (S-1).

NOTE: Use 1/2 watt resistors unless the step directs otherwise.

- ( ) Connect a 1-3/4" bare wire from lug 1 of crystal filter FL-1 (S-1) to lug 3 of switch EB (S-1).
- ( ) Connect a 2000  $\Omega$  (red-black-red) resistor from solder lug 2 of crystal filter FL-1 (S-1) to lug 2 of switch EB (NS).

- ( ) Place a 3/4" length of sleeving over one lead of a .001  $\mu$ fd disc capacitor. Connect this lead to lug 2 of switch EB (S-2) and connect the other lead to hole 15 on the IF circuit board (S-1).
- ( ) Connect a 1-1/4" bare wire from lug 4 of crystal filter FL-1 (S-1) to lug 5 of switch EC (S-1).

NOTE: Where a lead or wire passes through a connection and then goes to another point, as in the next step, it will count as two wires in the solder instruction (S-2), one entering and one leaving the connection.

- ( ) Place one lead of a .001  $\mu$ fd capacitor through lug 6 (S-2) to lug 1 (S-1) of switch EC. Use a 1/2" length of sleeving on the lead between lugs 1 and 6.
- ( ) Place a 1" length of sleeving over the free lead of this capacitor. Insert this lead through grommet CA in the center shield. Connect this lead to hole 14 in the modulator circuit board (S-1).
- ( ) Place a 2" bare wire from lug 3 of switch EC (S-1), through solder lug 3 of crystal filter FL-1 (S-2) to lug 4 of switch EC (S-1). Use a 3/4" length of sleeving on the wire between lug 3 of EC and solder lug 3.

NOTE: If you have the 400 Hz CW crystal filter installed, perform the next two steps. If this filter is not used, disregard the next two steps.

- ( ) Connect a 3/4" bare wire from lug 2 of crystal filter FL-2 (S-1) to lug 2 of switch EC (S-1).
- ( ) Connect a 3/4" bare wire from lug 1 of crystal filter FL-2 (S-1) to lug 1 of switch EB (S-1).

- ( ) Place a 3/4" length of sleeving on each lead of a 24 pf mica capacitor. Connect the capacitor between 15 (S-1) and 16 (S-1) on the modulator circuit board. Position this capacitor on edge next to the center pin of tube socket V2.

- ( ) Place a 3/4" length of sleeving on a 1-1/4" length of bare wire. Connect this wire between the center pin of tube socket V16 (S-1) and 17 (S-1) on the modulator circuit board. Solder the wire directly to the foil at 17, as there is no hole at this location.
- ( ) Connect a 12 pf mica capacitor between 18 (S-1) and the adjacent foil (S-1) of the modulator circuit board. Solder each lead directly to the foil as there are no holes at these locations.
- ( ) Cut both leads of a .02  $\mu$ fd disc capacitor to 1/4". Connect this capacitor between the indicated foils on the RF-driver circuit board. Solder each lead directly to the foil as there are no holes at these locations.
- ( ) Place a 5/8" length of sleeving on each lead of a silicon diode (#57-27). Connect the cathode lead to lug 3 of jack AA (NS) and the other lead to 16 on the audio circuit board (S-1).
- ( ) Connect the lead from the banded end of a .2  $\mu$ fd resin capacitor to lug 3 of jack AA (S-3). Connect the other lead to lug 4 of terminal strip BA (NS).
- ( ) Connect a 330  $\Omega$  (orange-orange-brown) resistor between lugs 2 (S-3) and 4 (S-2) of terminal strip BA.
- ( ) Connect the lead from the banded end of a .05  $\mu$ fd tubular capacitor to 20 on the audio circuit board (S-1). Connect the other lead to lug 1 of terminal strip BA (S-3).
- ( ) Connect a 2-1/2" length of large bare wire from lug 12 of relay socket BG (S-1), through lug 2 of socket AJ (S-2), to lug 2 of switch AK (S-1). Be sure this wire does not touch any other lugs on the relay socket.
- ( ) Connect a .01  $\mu$ fd disc capacitor from lug 3 of terminal strip BH (NS) to the solder lug at BH (S-2).
- ( ) Connect a .02  $\mu$ fd disc capacitor from lug 14 of relay socket BG (S-2) to lug 2 of terminal strip BH (NS).
- ( ) Connect a 1000  $\Omega$  (brown-black-red) resistor between lugs 1 (NS) and 2 (S-3) of terminal strip BH.

NOTE: When a .005  $\mu$ fd disc capacitor is called for, do not use the 1.6 KV capacitors unless they are specified in the step.

- ( ) Connect a .005  $\mu$ fd disc capacitor between lugs 1 (NS) and 2 (NS) of terminal strip BK.
- ( ) Connect a .005  $\mu$ fd 1.6 KV disc capacitor between lugs 2 (NS) and 4 (NS) of terminal strip BK.
- ( ) Connect a 10 K $\Omega$  (brown-black-orange) resistor between lugs 1 (NS) and 2 (S-3) of terminal strip BK.
- ( ) Connect a 100 pf mica capacitor from lug DB1 (NS) to solder lug BS (NS).
- ( ) Connect a 180 pf mica capacitor from lug 8 of switch BP (S-1) to solder lug BS (NS).
- ( ) Connect a 24 pf mica capacitor from lug 7 of switch BP (S-1) to solder lug BS (NS).
- ( ) Refer to Detail 3-4B and prepare six resistor-capacitor combinations to be installed in the next six steps. Use 10  $\Omega$  (brown-black-black) resistors and .005  $\mu$ fd disc capacitors.

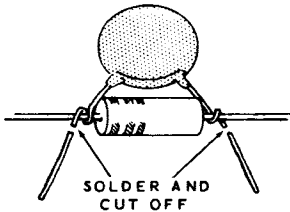

Detail 3-4B

NOTE: In the next six steps, use the upper (furthest from the socket) hole in each tube socket lug when it is available.

- ( ) Connect a resistor-capacitor combination between lugs 1 (NS) and 9 (S-1) of tube socket V9.

- ( ) Connect a resistor-capacitor combination between lugs 4 (NS) and 10 (NS) of tube socket V9.
- ( ) Connect a resistor-capacitor combination between lugs 6 (NS) and 11 (S-1) of tube socket V9.
- ( ) Connect a resistor-capacitor combination between lugs 1 (NS) and 9 (NS) of tube socket V8.
- ( ) Connect a resistor-capacitor combination between lugs 4 (NS) and 10 (S-1) of tube socket V8.
- ( ) Connect a resistor-capacitor combination between lugs 6 (NS) and 11 (S-1) of tube socket V8.
- ( ) Connect a 1-1/2" bare wire from lug 7 (S-1) through lug 8 (S-2) to lug 12 (S-1) of tube socket V9.
- ( ) Pass one lead of a .005  $\mu$ fd disc capacitor through lug 8 (S-2) to lug 12 of tube socket V8. Connect the other lead to lug 7 of tube socket V8 (S-3).
- ( ) Connect a .005  $\mu$ fd disc capacitor between lugs 2 (S-4) and 9 (S-2) of tube socket V8.
- ( ) Connect a 22 K $\Omega$  (red-red-orange) resistor between lugs 1 (NS) and 4 (NS) of terminal strip EA.
- ( ) Connect a 3.3 megohm (orange-orange-green) resistor between lugs 2 (NS) and 4 (NS) of terminal strip EA.
- ( ) Connect a .02  $\mu$ fd disc capacitor between lugs 3 (NS) and 4 (S-4) of terminal strip EA.
- ( ) Connect a .005  $\mu$ fd disc capacitor between lugs 2 (NS) and 3 (NS) of terminal strip BR.
- ( ) Connect a .005  $\mu$ fd disc capacitor between lugs 3 (S-2) and 4 (NS) of terminal strip BR.



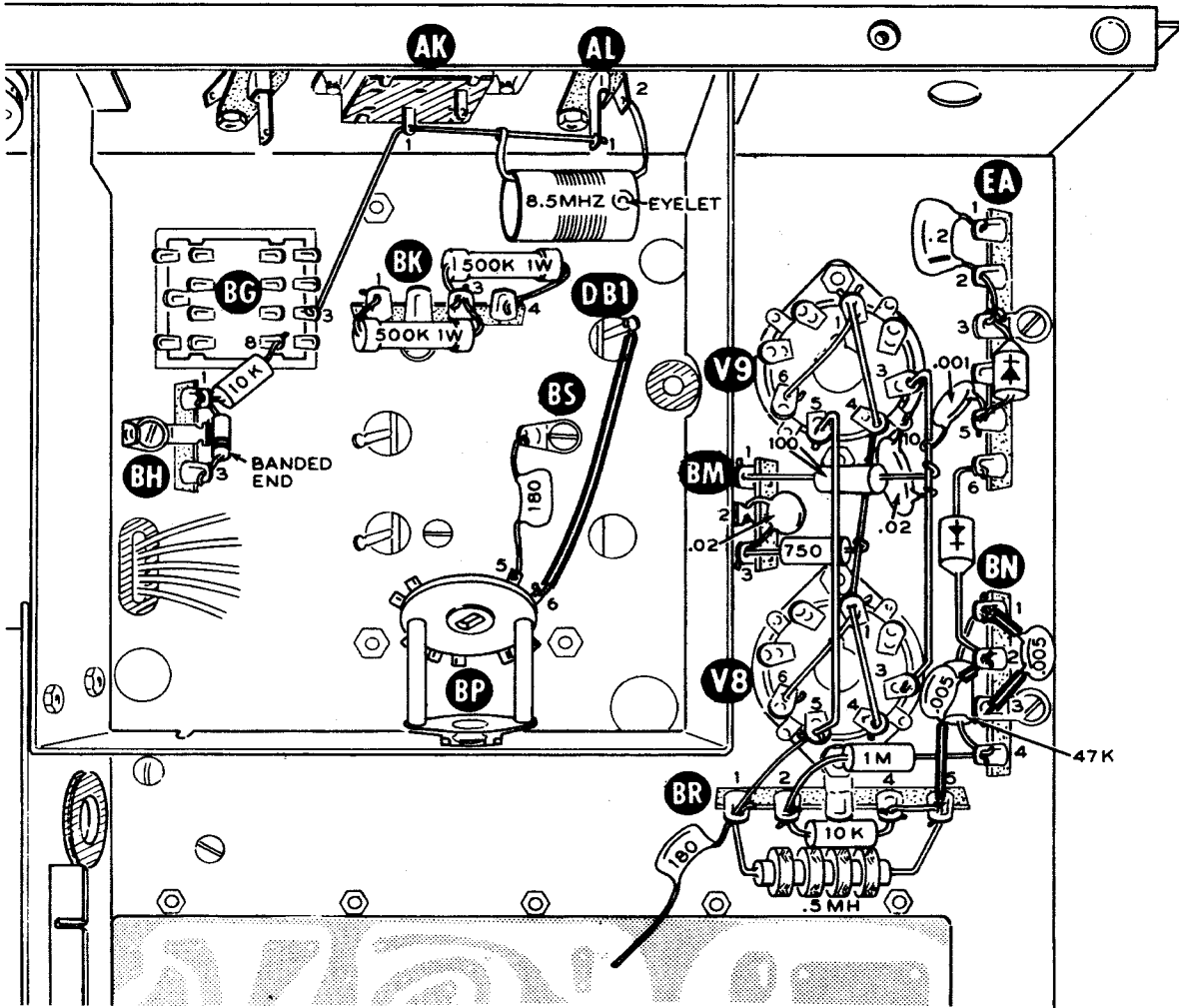

PICTORIAL 3-5

Refer to Pictorial 3-5 for the following steps.

- ( ) Connect a 10 KΩ (brown-black-orange) resistor from lug 1 of terminal strip BH (NS) to lug 8 of relay socket BG (S-2).
- ( ) Connect the lead from the banded end of a germanium diode, #56-26 (brown-white-brown), to lug 3 of terminal strip BH (S-3). Connect the other lead to lug 1 of terminal strip BH (S-3).
- ( ) Connect a 500 KΩ precision 1% resistor between lugs 1 (S-4) and 3 (NS) of terminal strip BK.
- ( ) Connect a 500 KΩ precision 1% resistor between lugs 3 (S-2) and 4 (S-4) of terminal strip BK.
- ( ) Place a 1-1/2" length of sleeving on a 2" length of large bare wire. Connect the wire from DB1 (S-2) to lug 6 of switch BP (S-1).
- ( ) Connect a 180 pf mica capacitor from solder lug BS (S-4) to lug 5 of switch BP (S-1).

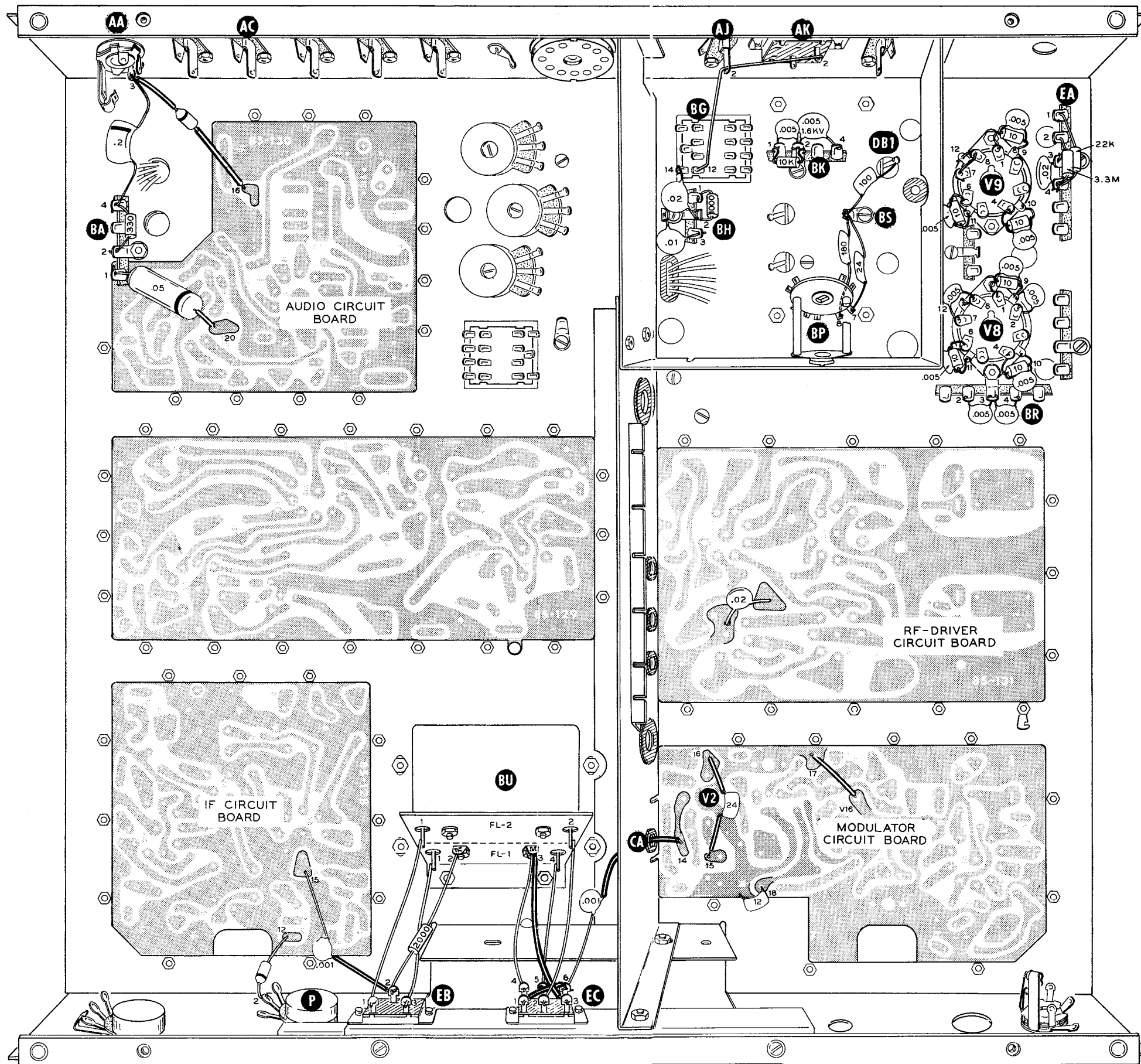

PICTORIAL 3-4

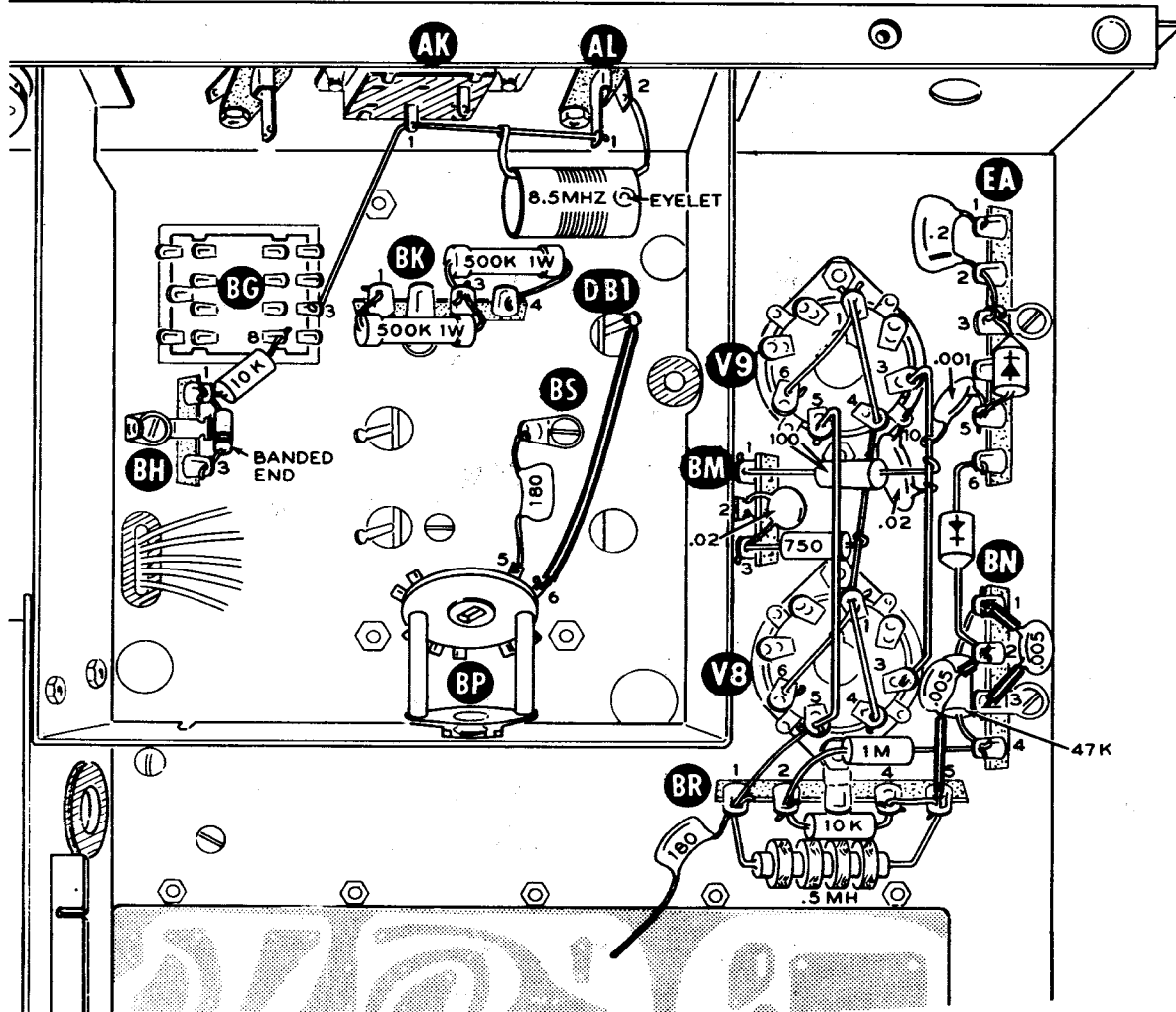

**PICTORIAL 3-5**  
(Repeat)

( ) Connect an 8.5 MHz trap coil (#40-546) from lug 2 of phono socket AL (S-1) to the bare wire connected to lug 1 of phono socket AL (S-1). Position the end of the coil with the eyelet as shown. Be sure that the coil does not touch terminal strip BK.

**NOTE:** In steps requiring large bare wire, do not bend the wire around the lugs to which it is connected, as that part may be damaged.

**NOTE:** In the next two steps, position the wire through the lower (closest to the socket) holes in the tube socket lugs.

( ) Connect a 1" large bare wire between lugs 1 (NS) and 6 (S-2) of tube socket V9.

( ) Connect a 1" large bare wire between lugs 1 (NS) and 6 (S-2) of tube socket V8.

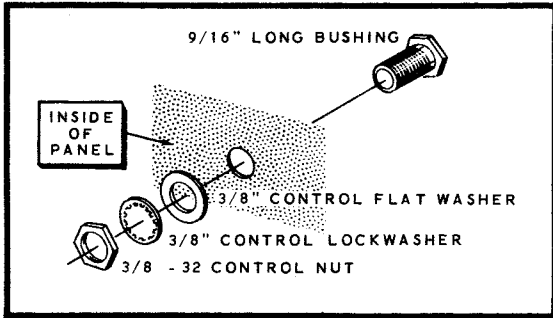
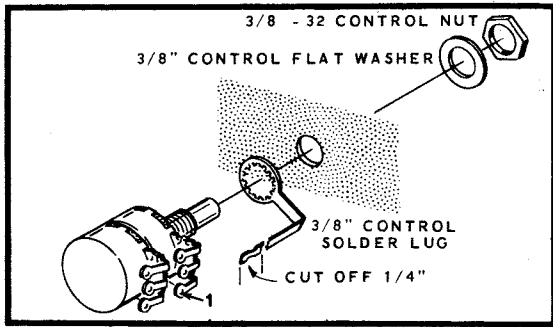
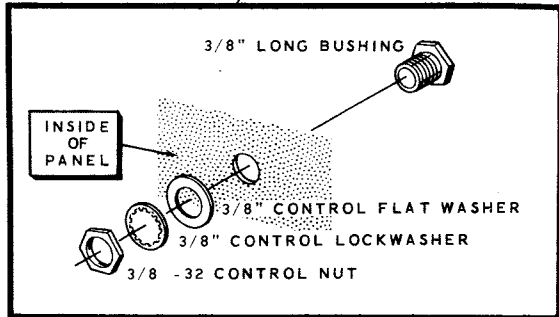
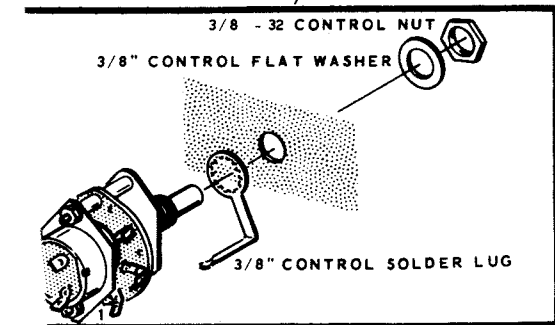
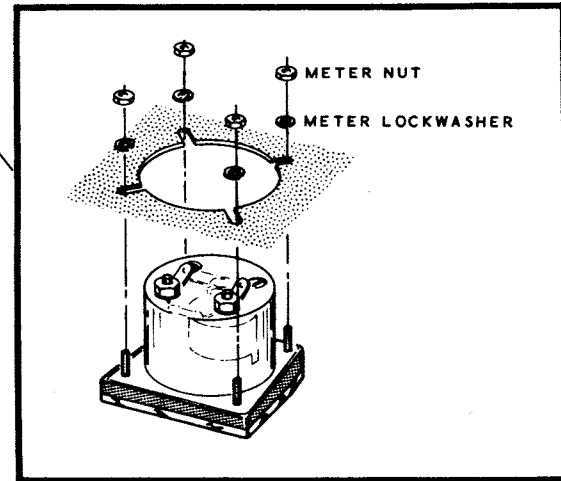
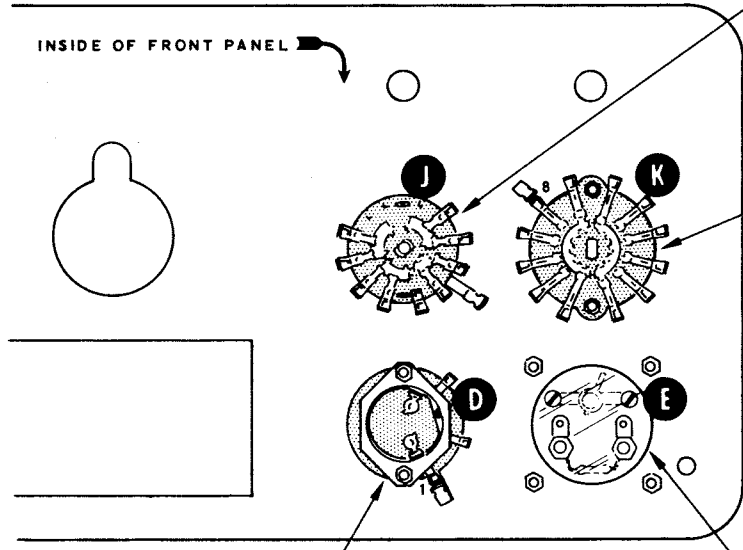
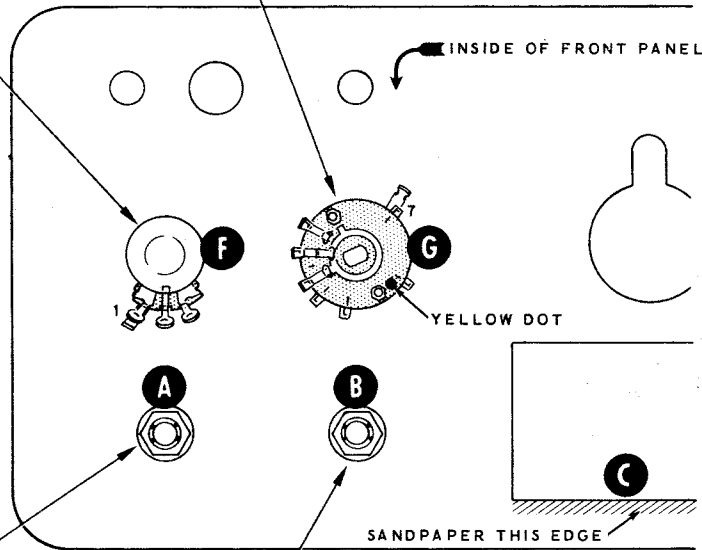
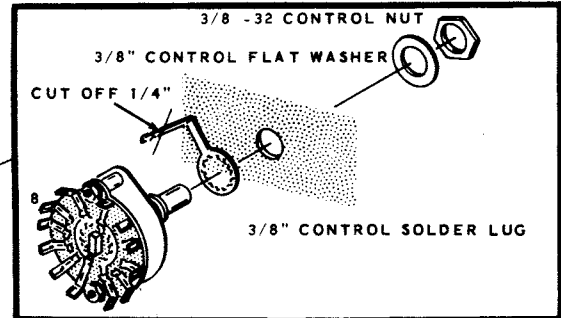
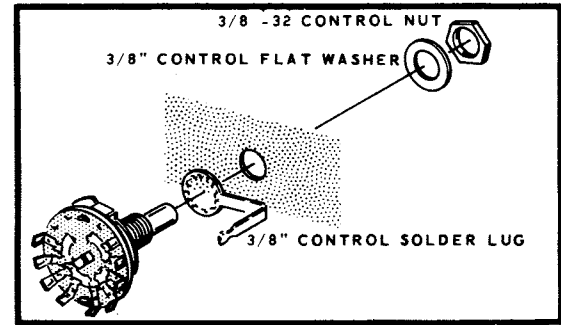
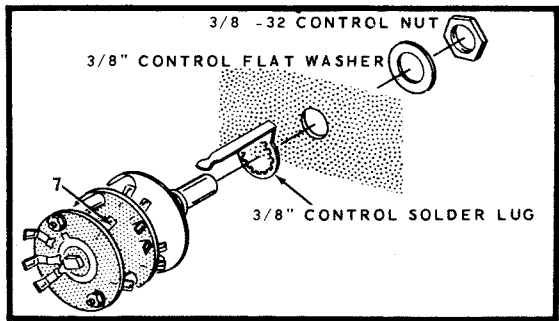

PICTORIAL 3-10

PICTORIAL 3-11



- ( ) Pass a 3" large bare wire through lugs 4 (S-2) and 1 (S-4) of tube socket V8 and through lugs 4 (S-3) and 1 (S-3) of tube socket V9. Use the upper holes in the tube socket lugs.
- ( ) Connect a .02  $\mu$ fd disc capacitor between lug 2 (S-1) and lug 3 (NS) of terminal strip BM. Position the body of the capacitor down against the chassis as shown.
- ( ) Connect one lead of a 750  $\Omega$  (violet-green-brown) resistor to the bare wire connected to lug 1 of tube socket V8 (S-1). Connect the other lead to lug 3 of terminal strip BM (S-3).
- ( ) Prepare two 3" lengths of large bare wire, as shown in Detail 3-5A, to be installed in the following two steps.
- ( ) Connect a .02  $\mu$ fd disc capacitor from lug 10 of tube socket V9 (S-2) to the bare wire connected to lug 3 of tube socket V9 (S-1).
- ( ) Connect one lead of a .001  $\mu$ fd disc capacitor to the bare wire connected to lug 3 of tube socket V9 (S-1). Connect the other lead to lug 5 of terminal strip EA (NS).
- ( ) Connect the lead from the cathode end of a silicon diode (#57-27) to lug 3 of terminal strip EA (NS). Connect the other lead to lug 5 of terminal strip EA (S-3).
- ( ) Connect the lead from the cathode end of a silicon diode (#57-27) to lug 2 of terminal strip BN (NS). Connect the other lead to lug 6 of terminal strip EA (S-4).
- ( ) Place the lead from the banded end of a .2  $\mu$ fd resin capacitor through lug 2 (S-3) to lug 3 (S-3) of terminal strip EA. Connect the other lead to lug 1 of terminal strip EA (S-2).

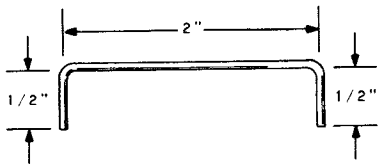

Detail 3-5A

NOTE: When installing the wires in the next two steps, position the wire ends straight down through the upper holes in the tube socket lugs. It may be necessary to bend the lugs slightly. Do not attempt to bend the wires around the lugs.

- ( ) Connect one of the 3" wires between lug 5 of tube socket V9 (S-1) and lug 5 of tube socket V8 (NS). Position the wire straight up.
- ( ) Connect the other 3" wire from lug 3 of tube socket V9 (S-1) to lug 3 of tube socket V8 (S-1). Position the wire straight up.
- ( ) Connect one lead of a 100  $\Omega$  (brown-black-brown) resistor to the bare wire connected to lug 3 of tube socket V8 (S-1). Connect the other lead to lug 1 of terminal strip BM (S-2).
- ( ) Place a 1/4" length of sleeving on each lead of a .005  $\mu$ fd disc capacitor. Connect this capacitor between lugs 1 (NS) and 3 (S-2) of terminal strip BN.
- ( ) Connect a 47 K $\Omega$  (yellow-violet-orange) resistor between lugs 1 (S-5) and 4 (NS) of terminal strip BN.
- ( ) Connect a 1 megohm (brown-black-green) resistor from lug 2 of terminal strip BR (NS) to lug 4 of terminal strip BN (S-3).
- ( ) Connect a .005  $\mu$ fd disc capacitor from lug 2 of terminal strip BN (S-4) to lug 5 of terminal strip BR (NS). Use 3/8" of sleeving on each lead.
- ( ) Connect a 10 K $\Omega$  (brown-black-orange) resistor between lugs 2 (S-4) and 4 (NS) of terminal strip BR.
- ( ) Place one lead of a .5 mh choke (#45-30) through lug 5 (S-3) to lug 4 (S-4) of terminal strip BR. Connect the other choke lead to lug 1 of BR (NS).
- ( ) Place one lead of a 180 pf mica capacitor through lug 1 of terminal strip BR (S-3) to lug 5 of tube socket V8 (S-2). Leave the other capacitor lead free. It will be connected later.

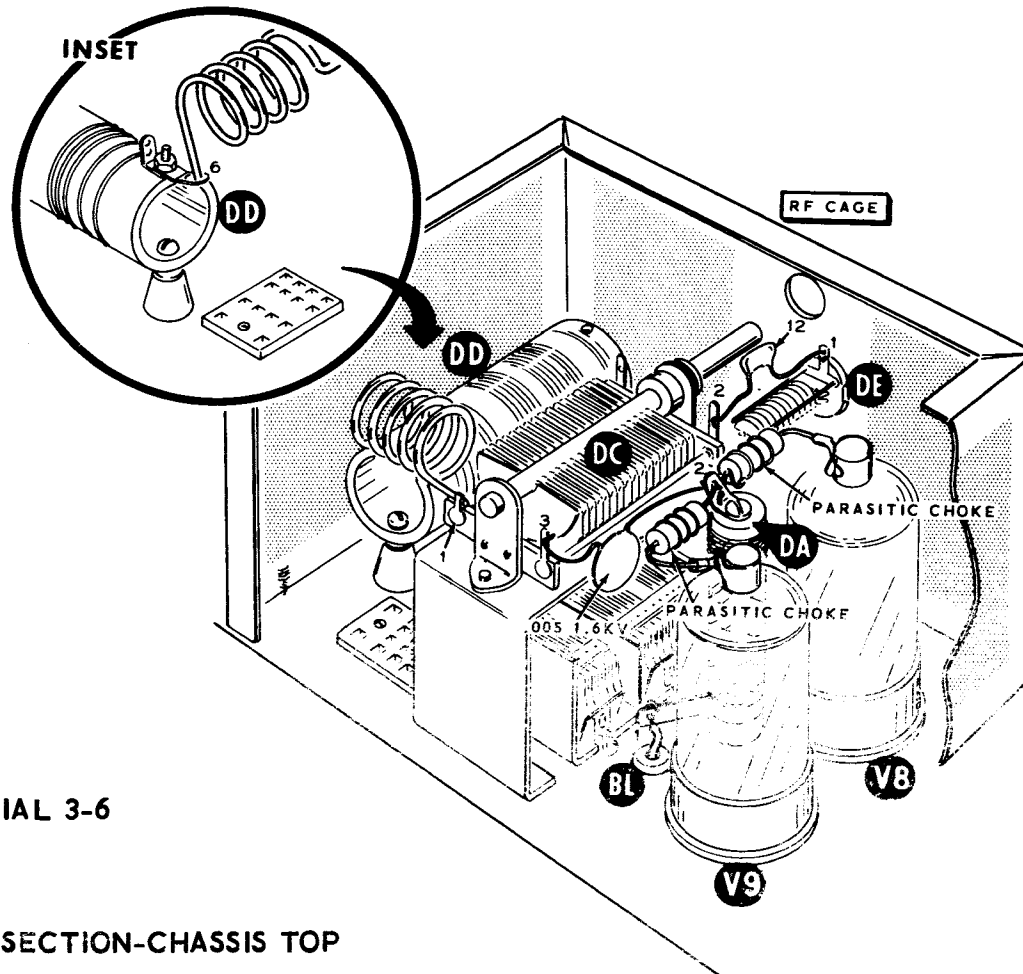

PICTORIAL 3-6

WIRING RF SECTION-CHASSIS TOP

Refer to Pictorial 3-6 for the following steps.

- ( ) Connect the free end of the large red wire extending from grommet BL to lug 1 of choke DA (S-1).
- ( ) Refer to Detail 3-6A and mount the 20 pf variable capacitor (#26-24) at DE on the RF cage. Use a 1/4" nylon control shoulder washer (#75-18), a 1/4" fiber control flat washer, a 1/4" control solder lug, and the nut supplied with the capacitor. Position the capacitor and solder lug as shown. Tighten the nut carefully to avoid cutting through the fiber washer.
- ( ) Connect a 12 pf mica capacitor from lug 1 of capacitor DE (S-1) to lug 2 of capacitor DC (S-1).
- ( ) Connect a .005  $\mu$ fd 1.6 KV disc capacitor from lug 3 of capacitor DC (S-1) to lug 2 of choke DA (NS).
- ( ) Locate the two 6146 tubes and install them in sockets V8 and V9.

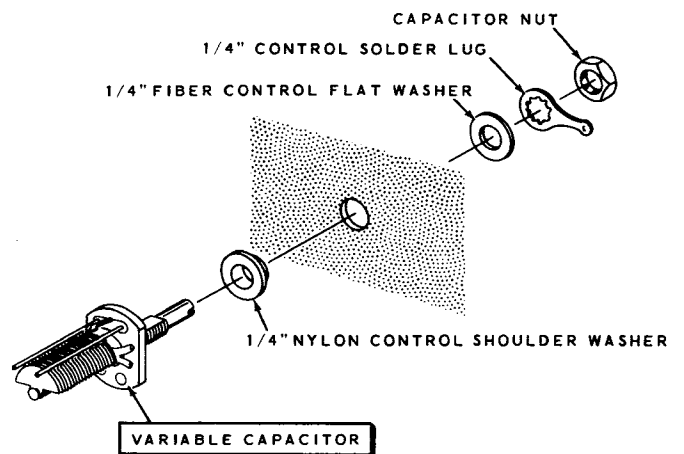

Detail 3-6A

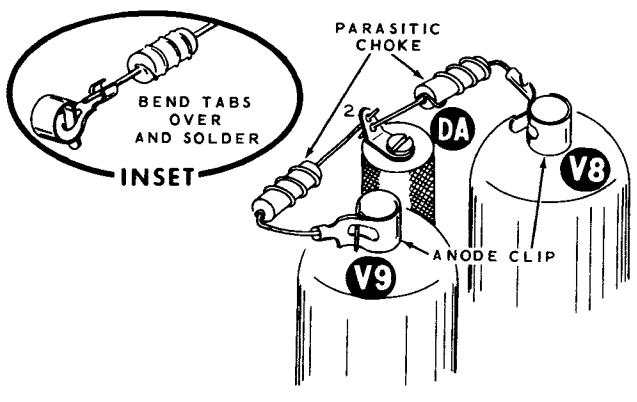

Detail 3-6B

Refer to Detail 3-6B for the following steps.

- ( ) Locate both parasitic chokes (#45-53) and both anode clips.
- ( ) Install a clip on one end of each of the chokes as shown in the inset drawing on Detail 3-6B.
- ( ) Push both clips on the caps of tubes V8 and V9.
- ( ) Connect the free lead of the parasitic choke coming from tube V8 to the lower hole in lug 2 of choke DA (NS).
- ( ) Connect the free lead of the parasitic choke coming from the anode clip on tube V9 to the upper hole in lug 2 of choke DA (S-3).
- ( ) Refer to Detail 3-6C and cut 5/8" from the long end and 1/8" from the short end of the 10-meter coil (#40-549), as shown.

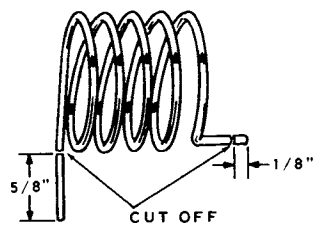

Detail 3-6C

- ( ) Connect the 10-meter coil from lug 6 of final tank coil DD (S-1) to lug 1 of capacitor DC (S-1). Position the coil as shown in the inset drawing in Pictorial 3-6.

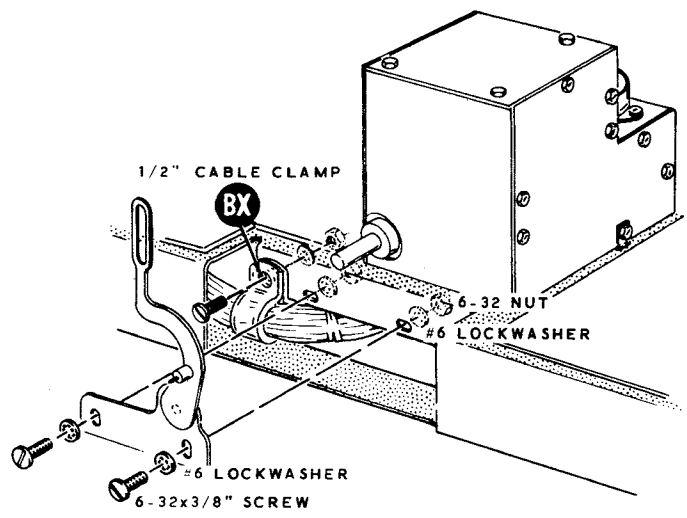

PICTORIAL 3-7

DIAL MOUNTING

Refer to Pictorial 3-7 for the following steps.

Use the parts from the #100-450 package for the following steps.

- ( ) Refer to Detail 3-7A and install the nylon spiral follower on the dial pointer drive arm. Use a 3-48 x 1/8" screw. Be careful not to overtighten the screw.

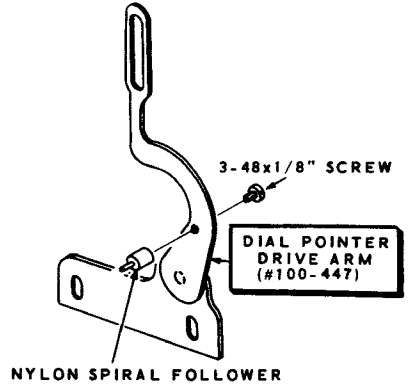

Detail 3-7A

- ( ) Mount the dial pointer drive arm on the chassis. Use 6-32 x 3/8" hardware. Position the screws in the center of the chassis and dial pointer drive arm slots.

- ( ) Place a 1/2" cable clamp over the wire and coaxial cable harnesses. Mount the cable clamp at BX on the front of the chassis, as shown, with 6-32 x 3/8" hardware.

Refer to Pictorial 3-8 for the following steps.

- ( ) Mount the plastic dial window (#464-30-1), two pilot lamp sockets (#434-44) and the dial pointer assembly (#100-443), to the dial mounting bracket (#204-553). Use 3-48 x 3/8" flat head hardware. Be sure to position the plastic dial window and dial pointer assembly as shown.
- ( ) Mount the dial mounting bracket on the LMO. Use the two top front screws of the LMO. Position the stud on the rear of the dial pointer into the slot of the dial pointer drive arm.

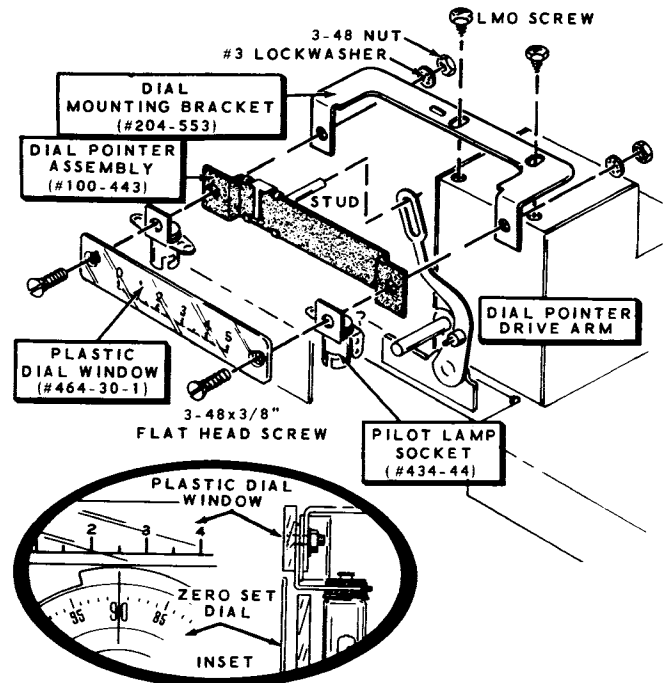

PICTORIAL 3-8

Refer to Detail 3-8A for the following steps.

- ( ) Twist together a 6-1/2" brown wire and a 6-1/2" white wire to form a twisted pair with approximately 2 turns per inch.
- ( ) At one end of this twisted pair of wires, connect the brown wire to lug 1 (S-1) and the white wire to lug 2 (S-1) of pilot lamp socket DF.
- ( ) Position the other end of this twisted pair of wires between the dial pointer drive arm and the front of the LMO. Connect the brown wire to lug 1 (NS) and the white wire to lug 2 (NS) of pilot lamp socket DG.
- ( ) Twist together an 8" brown wire and a 6-1/2" white wire to form a twisted pair. At the end where the wire ends are even, connect the brown wire to lug 1(S-2) and the white wire to lug 2 (S-2) of pilot lamp socket DG. Bend down lugs 1 and 2 of socket DG so it clears the dial pointer. The other ends of these wires will be connected later.
- ( ) Install pilot lamps and pilot lamp shields in pilot lamp sockets DF and DG. Position the shields as shown. Be sure none of the lugs of the pilot lamp sockets touch any other metal parts.

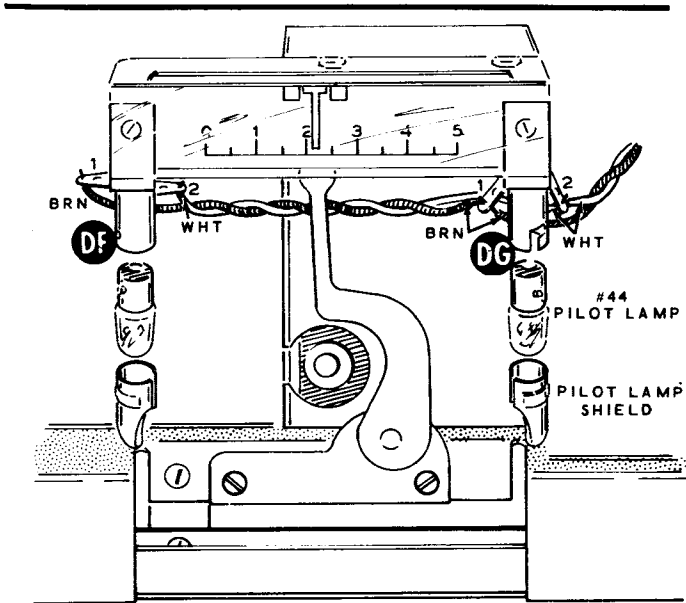

Detail 3-8A



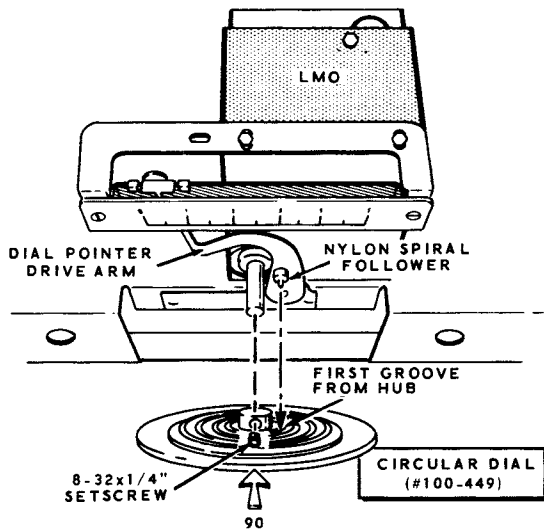

Detail 3-8B

Refer to Detail 3-8B for the following steps.

- ( ) Turn the shaft of the LMO fully counter-clockwise, against the stop.
- ( ) Start an 8-32 x 1/4" setscrew in the tapped hole in the hub of the circular dial (#100-449).

- ( ) Position the circular dial on the LMO shaft with the "90" marking straight up, and position the nylon spiral follower in the first groove (nearest the hub) of the circular dial; then tighten the setscrew.

NOTE: If the nylon follower will not fit into the first groove of the circular dial, loosen the hardware that secures the dial pointer drive arm to the chassis. Then move the dial pointer drive arm as required. Retighten the hardware.

- ( ) Check to see that the front of the plastic dial window is flush with the zero set dial on the circular dial. If not, loosen the two screws in the top of the LMO and adjust the dial mounting bracket as required. Retighten the screws. See the inset drawing on Pictorial 3-8.

NOTE: If the zero set dial does not rotate freely under the plastic dial window, bend the dial mounting bracket up to obtain sufficient clearance.

- ( ) Check to see that the "90" marking on the circular dial is directly under the "2-1/2" mark on the plastic dial window when the shaft of the LMO is turned fully counter-clockwise. If not, loosen the circular dial setscrew and make the necessary adjustment. Retighten the setscrew.

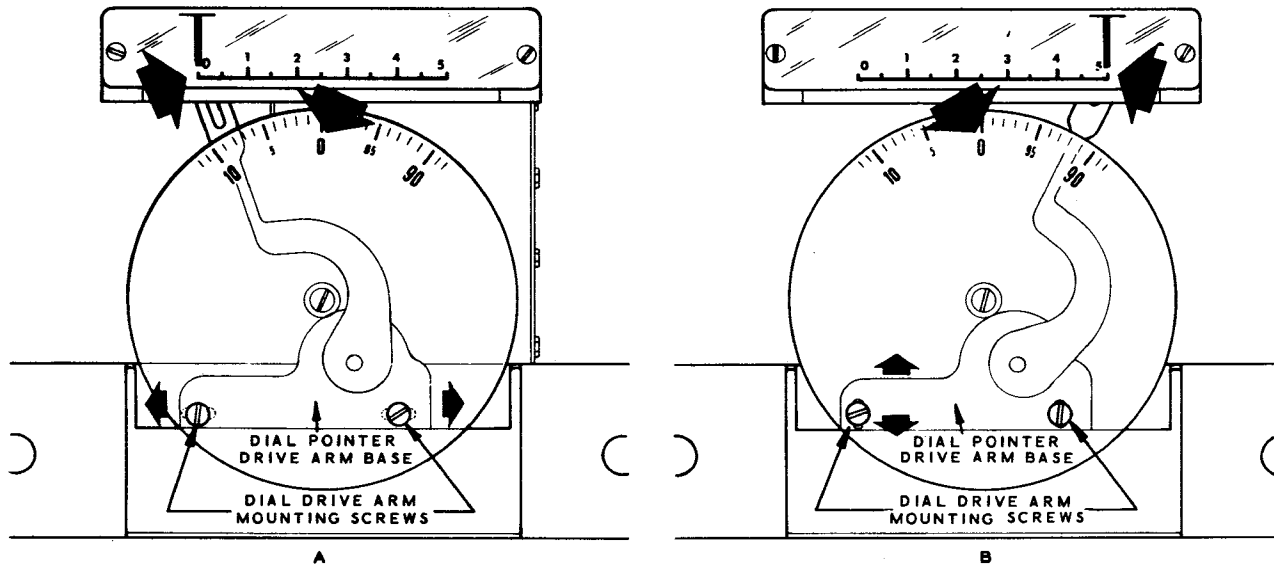

PICTORIAL 3-9

Refer to the left-hand drawing in Pictorial 3-9 for the following steps.

- ( ) Rotate the circular dial clockwise from the fully counterclockwise position ("90" marking) to the first zero marking. The dial pointer should be at the zero marking on the plastic dial window. If not, perform one of the following two steps. Use the open-end wrench supplied.
- ( ) 1. If the dial pointer is to the right of the zero marking, loosen the dial pointer drive arm mounting screws, and move the dial pointer drive arm base to the right until the dial pointer is at zero. Do not move the dial pointer drive arm base up or down. Retighten the screws.
- ( ) 2. If the dial pointer is to the left of the zero marking, loosen the dial pointer drive arm mounting screws and move the dial pointer drive arm base to the left until the dial pointer is at zero. Do not move the dial pointer drive arm base up or down. Retighten the screws.

Refer to the right-hand drawing of Pictorial 3-9 for the following steps.

- ( ) Rotate the circular dial in a clockwise direction one revolution (zero to zero); this should move the dial pointer to the "1" marking on the plastic dial window. Each time the circular dial is rotated one more revolution clockwise, the dial pointer should advance one more number on the plastic dial window. After five complete revolutions the dial pointer should be at or very close to the "5" marking on the plastic dial window. If not, perform one of the following two steps.

**CAUTION:** When performing either of the two following steps, be very careful not to move the dial pointer drive arm base to the left or right, as this will disrupt the zero end dial pointer adjustment.

- ( ) 1. If the dial pointer is to the left of the "5" marking, loosen the dial pointer drive arm mounting screws and move the dial pointer drive arm base up until the dial pointer is at the "5" marking. Retighten the screws.

- ( ) 2. If the dial pointer is to the right of the "5" marking, loosen the dial pointer drive arm mounting screws and move the dial pointer drive arm base down until the dial pointer is at the "5" marking. Retighten the screws.

The preceding adjustment may affect the dial pointer setting at the zero marking. Repeat the entire dial adjustment procedure as many times as necessary to obtain proper dial pointer calibration. Because the dial pointer is only a turns counter, it need not be exactly at a number when the circular dial is at one of its five possible zero settings; however, the preceding steps should permit fairly close calibration. Rotating the circular dial from a fully counterclockwise position to a fully clockwise position will cause the dial pointer to go to the left of the zero marking and to the right of the "5" marking on the plastic dial window. These adjustments in no way affect frequency calibration, which depends only on the circular dial reading.

#### MOUNTING PARTS-FRONT PANEL

Refer to Pictorial 3-10 (fold-out from Page 48) for the following steps.

- ( ) Lay a soft cloth on the work area to prevent scratching of the front panel. Position the panel as shown.
- ( ) Use sandpaper to remove any excess paint from the top inside edge of hole C.
- NOTE: Wherever control solder lugs are used on the front panel, scrape off any excess paint around the hole on the inside of the panel.
- ( ) Place tape around the edge of the panel to protect the paint from chipping.
- ( ) Mount a 10 K $\Omega$  1 megohm dual control (#12-48) at F. Use a 3/8" control solder lug, a 3/8" control flat washer, and a 3/8-32 control nut. Position the control and solder lug as shown. Bend the solder lug against lug 1 and cut off the 1/4" excess.
- ( ) Mount a 4-position double wafer switch (#63-399) at G. Use a 3/8" control solder lug, a 3/8" control flat washer, and a 3/8-32 control nut. Position the solder lug as close as possible to lug 7 of the rear wafer.
- ( ) Install a 9/16" long bushing at A. Use a 3/8" control flat washer, a 3/8" control lockwasher, and a 3/8-32 control nut. Do not tighten the control nut at this time.
- ( ) Install a 3/8" long bushing at B. Use a 3/8" control flat washer, a 3/8" control lockwasher, and a 3/8-32 control nut. Do not tighten the nut at this time.
- Refer to Pictorial 3-11 (fold-out from Page 48) for the following steps.
- ( ) Mount a 3-position wafer switch (#63-400) at J. Use a 3/8" control solder lug, a 3/8" control flat washer, and a 3/8-32 control nut. Position the switch and solder lug as shown.
- ( ) Prepare a 3/8" control solder lug by cutting 1/4" off of the end.
- ( ) Mount a 5-position single wafer switch (#63-94) at K with the prepared 3/8" control solder lug, a 3/8" control flat washer, and a 3/8-32 control nut. This switch is symmetrical and can be positioned either way; position the lugs as shown. Bend the solder lug against lug 8 as shown.
- ( ) Remove the shorting clip from between the lugs of the meter (#407-101).
- ( ) Mount the meter at E, using the lockwashers and nuts furnished with the meter. Do not overtighten the nuts.
- ( ) Mount the 4-position single wafer switch with snap switch (#63-349) at D. Use a 3/8" control solder lug, a 3/8" control flat washer, and a 3/8-32 control nut. Position the switch and solder lug as shown. Bend the solder lug against lug 1 of the switch. Remove the cover from the switch and set it aside for use later.

## FRONT PANEL WIRING

**NOTE:** It is advisable to recheck the front apron alignment of the chassis at this time. Refer to the first step on Page 26.

Refer to Pictorial 3-12 for the following steps.

- ( ) Connect a 1-1/4" black wire between lugs 1 (S-2) and 6 (NS) of control F. Be sure the control solder lug is soldered to lug 1 of the control.

**NOTE:** To make it easier to locate the lugs, each lug location (hole) of the rotary switches will be given a number, even though every hole does not have a lug.

- ( ) Connect a bare wire from lug 7 on the rear wafer of switch G (S-1), to the control solder lug mounted with the switch (S-1). Make this wire as short as possible.
- ( ) Position the bottom edge of the front panel against the front of the chassis. It may be necessary to prop the top edge of the front panel up slightly to make wiring easier.
- ( ) Connect the violet wire from BO#23 of the wire harness to lug 3 of control F (S-1).

Connect the wires from BO#23 of the wire harness to the front wafer (nearest the front panel) of switch G as follows:

- ( ) Yellow-white to lug 11 (S-1).
- ( ) Blue to lug 9 (S-1).
- ( ) Violet-violet-white to lug 6 (S-1).
- ( ) Connect a 5" black wire from lug 2 of control F (S-1) to lug 4 on the front wafer of switch G (S-1).
- ( ) Orange-orange-white to lug 13 (S-1).
- ( ) Blue-blue-white to lug 15 (S-1).

- ( ) Green to lug 16 (S-1).
- ( ) Blue-white to lug 17 (S-1).
- ( ) Gray-white to lug 18 (S-1).
- ( ) Red-white to lug 19 (S-1).
- ( ) Orange-white to lug 20 (S-1).
- ( ) Green-white to lug 1 (S-1).
- ( ) Black-white to lug 3 (S-1).

Connect the wires from BO#23 of the wire harness to the rear wafer of switch G as follows:

- ( ) Red-red-white to lug 18 (S-1).
- ( ) Black to lug 20 (S-1).
- ( ) Gray to lug 3 (S-1).

The black-black-white wire will be connected later.

**NOTE:** In the following four steps, connect only one end of each wire to the rear wafer of switch G. The free ends will be connected later.

- ( ) 2" black wire to lug 12 (S-1).
- ( ) 2-1/2" black wire to lug 13 (S-1).
- ( ) 3" black wire to lug 15 (S-1).
- ( ) 2-1/2" black wire to lug 17 (S-1).

Connect the cables from BO#12 of the coaxial harness to control F as follows:

- ( ) Orange: inner lead to lug 5 (S-1) and the shield to lug 6 (NS).
- ( ) Yellow: inner lead to lug 4 (NS) and the shield to lug 6 (S-3).
- ( ) Connect one end of a 3" black wire to lug 4 of control F (S-2). The other end will be connected later.

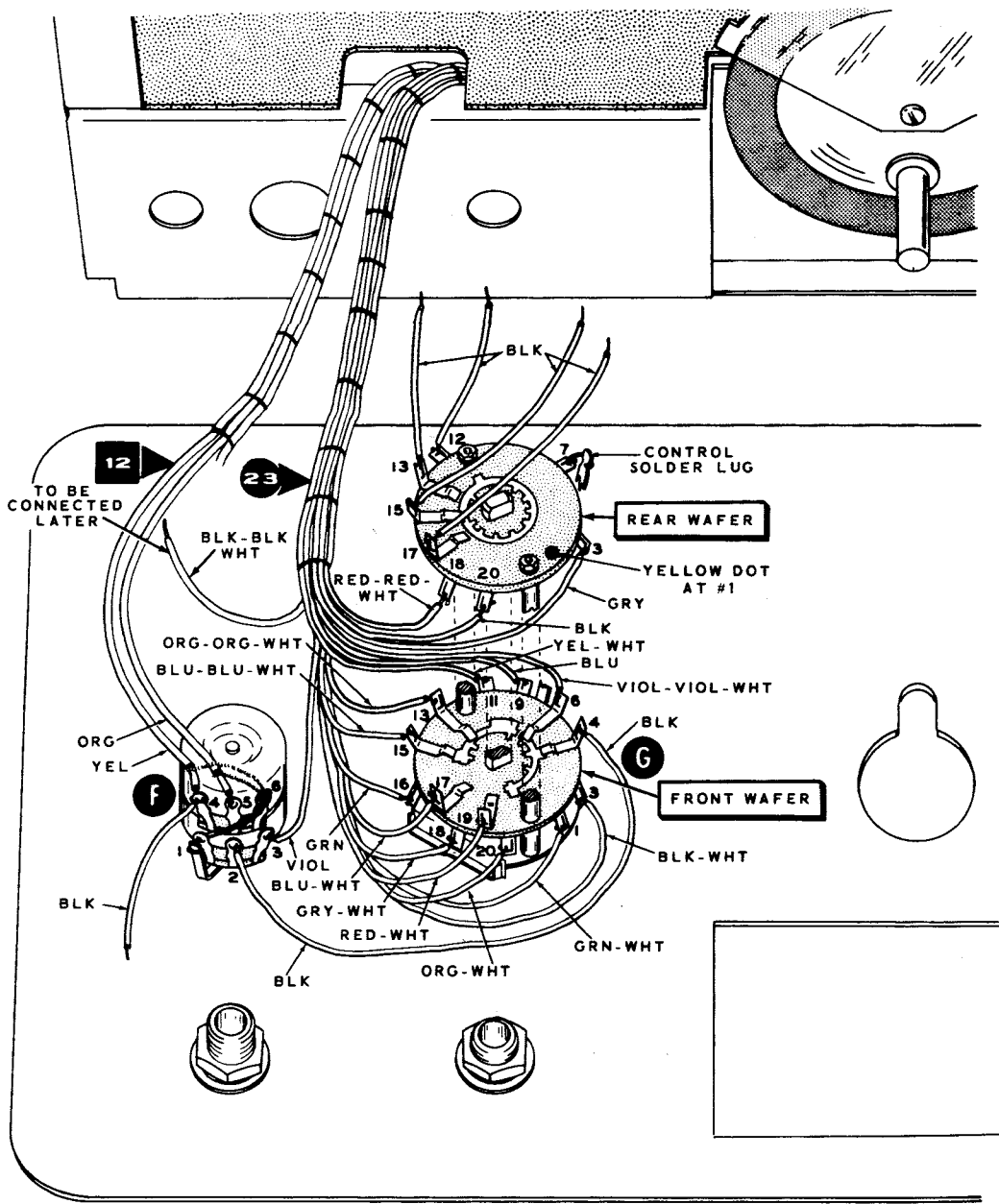

PICTORIAL 3-12

Refer to inset drawing #1 on Pictorial 3-13 for the following steps.

- ( ) Connect a 56  $\Omega$  (green-blue-black) resistor from lug 2 of switch J (NS) to the control solder lug mounted with the switch (NS).
- ( ) Connect a 100 pf mica capacitor from lug 1 of switch J (NS) to the control solder lug mounted with the switch (NS).
- ( ) Connect a 100  $\Omega$  (brown-black-brown) resistor between lugs 1 (NS) and 4 (S-1) of switch J.

Refer to Pictorial 3-13 for the following steps.

Connect the cables from BO#1 of the coaxial harness to switch J as follows:

- ( ) Violet: inner lead to lug 5 (S-1) and the shield to the control solder lug mounted with the switch (NS).
- ( ) White: inner lead to lug 3 (S-1) and the shield to the control solder lug mounted with the switch (NS).
- ( ) Orange: inner lead to lug 1 (S-3) and the shield to the control solder lug mounted with the switch (NS).
- ( ) Prepare the ends of a 10" length of coaxial cable as shown in Detail 3-13A. Install a phono plug at one end of the cable as shown.

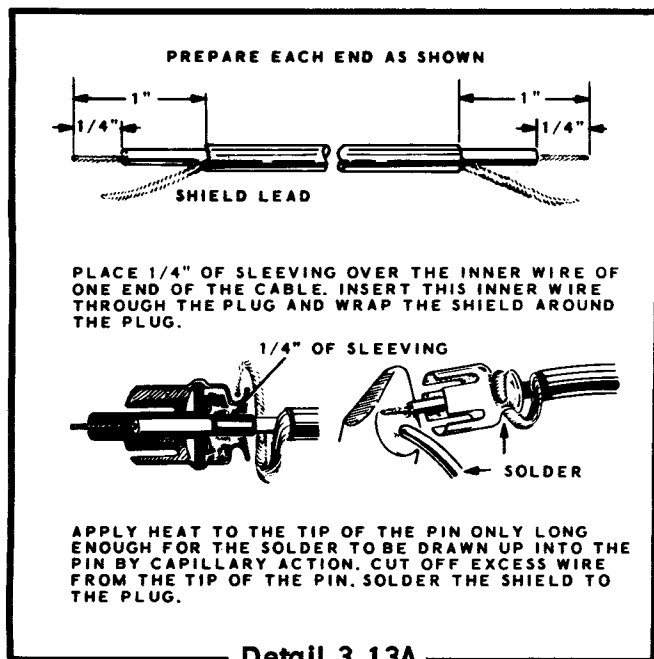

- ( ) At the free end of this cable, connect the inner lead to lug 2 of switch J (S-2), and the shield to the control solder lug mounted with the switch (S-6). Position this cable as shown.

Connect the wires from BO#1 of the wire harness to switch J as follows:

- ( ) Orange-orange-white to lug 9 (S-1).
- ( ) Green-green-white to lug 10 (S-1).
- ( ) Black-black-white to lug 11 (S-1).
- ( ) Violet-violet-white to lug 12 (S-1).

Connect the wires from BO#1 of the wire harness to switch D as follows:

- ( ) White to lug 5 (S-1).
- ( ) Gray to lug 7 (S-1).
- ( ) Gray-white to lug 6 (S-1).
- ( ) Red-red-white to lug 3 (S-1).
- ( ) Now solder lug 1 of switch D to the control solder lug mounted with the switch (S-1).
- ( ) Replace the cover of the snap switch on switch D. Fit the opening over the wires as shown. Solder the switch cover to the switch. Refer to inset drawing #2 on Pictorial 3-13.
- ( ) Connect a 1-3/4" bare wire from lug 8 (S-2), through lug 10 (S-2), to lug 11 (S-1) of switch K. Be sure the control solder lug mounted with the switch is soldered to lug 8. Also make sure this wire clears lug 9.
- ( ) Connect a 5" black wire from lug 6 of switch K (S-1) to lug 2 of meter E (S-1).

Connect the wires from BO#1 of the wire harness to switch K as follows:

- ( ) Yellow to lug 7 (S-1).
- ( ) Black to lug 9 (S-1).

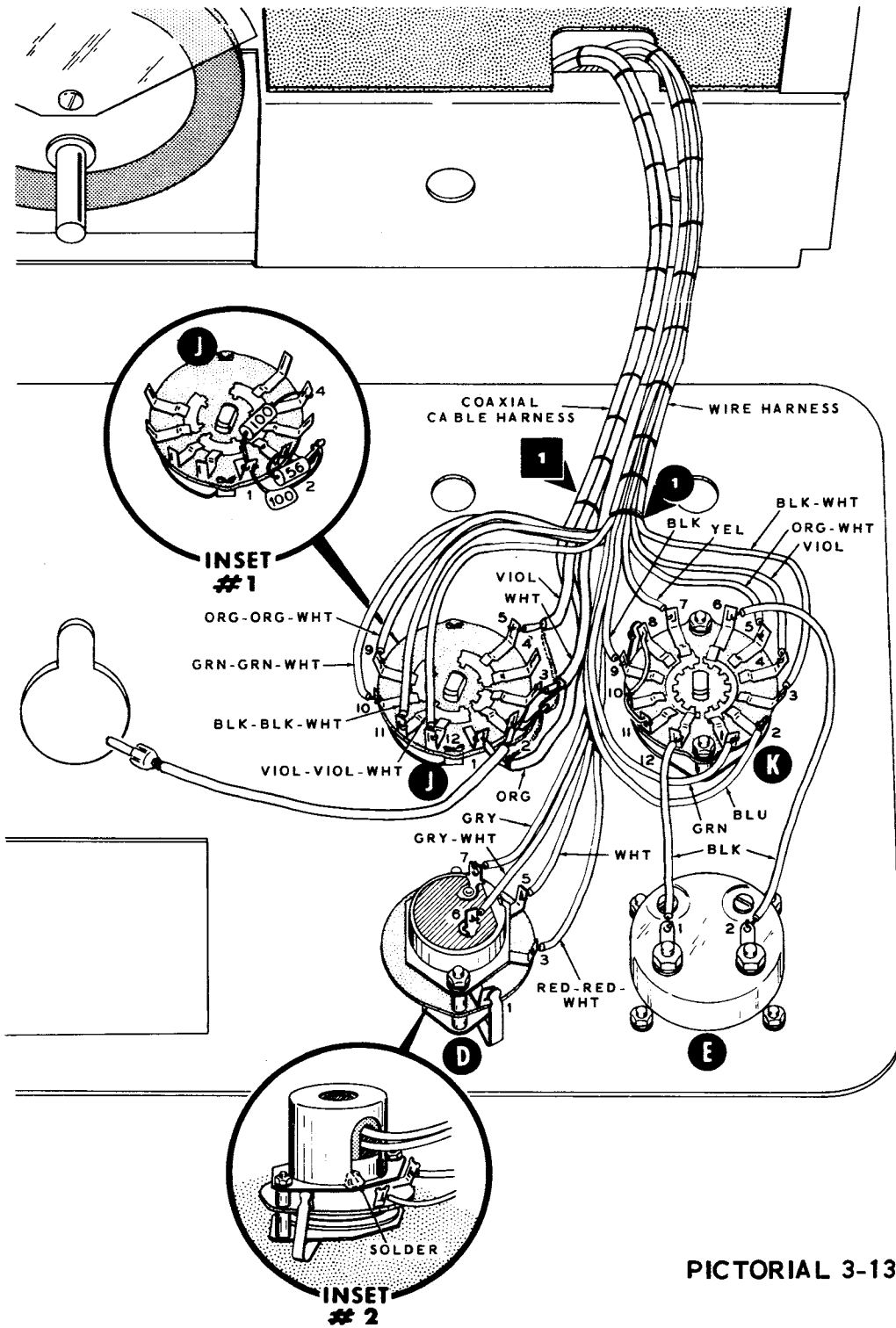

PICTORIAL 3-13

- ( ) Orange-white to lug 5 (S-1).
- ( ) Violet to lug 4 (S-1).
- ( ) Black-white to lug 3 (S-1).
- ( ) Blue to lug 2 (S-1).
- ( ) Green to lug 1 (S-1).
- ( ) Connect a 2-1/4" black wire from lug 12 of switch K (S-1) to lug 1 of meter E (S-1).

## FRONT PANEL MOUNTING

Refer to Pictorial 3-14 for the following steps.

- ( ) Remove the control nuts and control flat washers from the controls at R and P, and from jack L.
- ( ) Remove any tape along the edge of the panel that will be pinched by the chassis.
- ( ) Tip the front panel up into place and carefully bend the cable assemblies and wires between the switches so the front panel will fit against the front of the chassis. Do not pinch any wires between the front panel and chassis, and be careful not to break the switches at the ends of the front panel.
- ( ) Replace the control nuts and control flat washers at R, P, and L. Do not tighten the nuts at this time.
- ( ) Start 6-32 x 3/8" phillips head hardware at the top corners of the front panel. Do not tighten the hardware at this time.

Refer to Detail 3-14A for the following steps.

- ( ) Place the drive shaft bushing assembly (#455-42) over the dial drive pulley.
- ( ) Carefully lubricate the shaft of the dial drive pulley and the center bearing of the Zero set dial with a small amount of silicone grease.
- ( ) Push the dial drive bushing down into the keyhole slot so the dial drive pulley engages with the circular drive ring.
- ( ) Snap the zero set drive pulley (small pulley) onto the zero set dial. Position the pulley and dial as shown.
- ( ) Mount the dial escutcheon as follows: Start the shaft of the zero set pulley through the small hole in the escutcheon. Position the tabs at the top of the escutcheon inside the front panel. Slide the escutcheon in place with the dial drive bushing and shaft through the lower hole. Secure the dial drive bushing with the large flat washer, lockwasher, and nut.

**NOTE:** The amount of torque required to turn the circular dial can be adjusted by moving the dial drive bushing up or down.

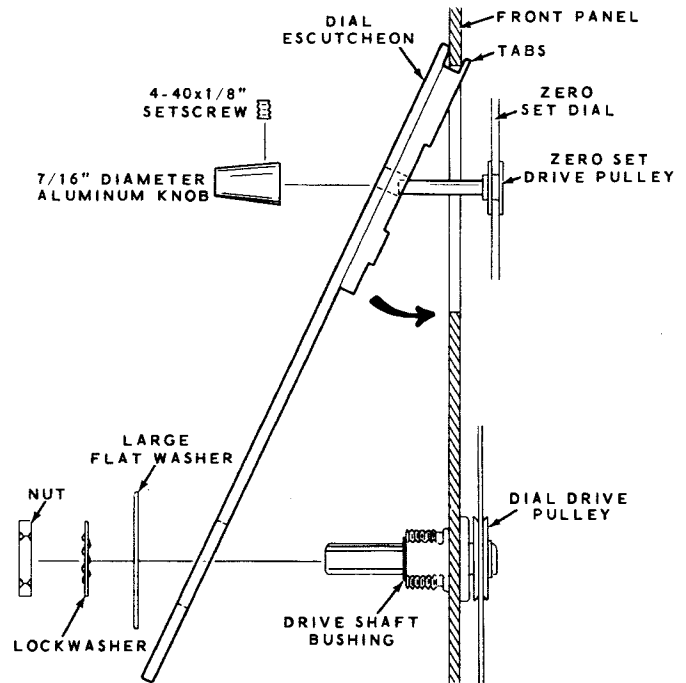

**Detail 3-14A**

- ( ) Push the zero set drive pulley flush with the inside of the dial escutcheon; then install the 7/16" diameter aluminum knob on the shaft of the zero set drive pulley with a 4-40 x 1/8" setscrew. Be sure the zero set dial does not rub against the circular dial plate. They must be separated by at least 1/64".

**NOTE:** The following adjustment of the front panel is critical and must be done carefully to obtain smooth operation of the dial mechanism.

- ( ) Align the small hole in the center of the escutcheon with the end of the LMO shaft by carefully moving the front panel. See the inset drawing on Pictorial 3-14. Tighten the control nuts at L, P, and R with the bottom edge of the front panel parallel with the bottom edge of the chassis. Also, tighten the hardware at the upper corners of the front panel.

Refer to Detail 3-14B for the following steps.

**NOTE:** Before mounting the female connector in the following step, be sure the small screw that holds the connector together is tight. Place some glue or fingernail polish over the head of this screw to keep it from working loose.



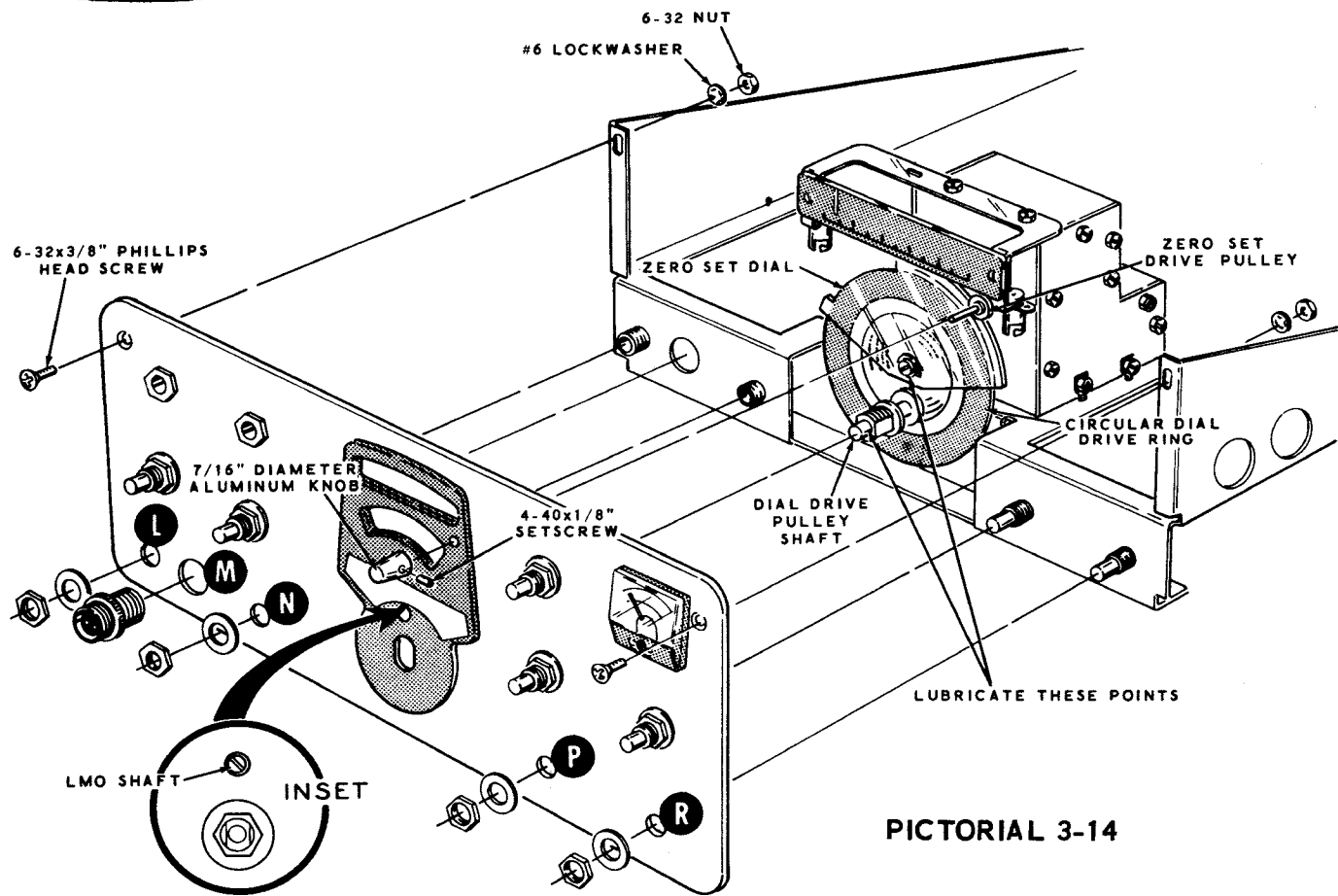

PICTORIAL 3-14

- ( ) Mount the female connector at M with the lockwasher and nut supplied with the connector. Position lug 1 as shown. The numbers are molded in the connector.
- ( ) Mount a rotary switch detent at N with a 3/8" control flat washer, a 3/8" control lockwasher, and a 3/8-32 control nut.
- ( ) Push the dial drive bushing down so the dial drive pulley engages with the circular drive ring; there should be just enough pressure to rotate the circular dial without slippage. Tighten the dial drive bushing. The amount of torque required to turn the circular dial can be adjusted by moving the dial drive bushing up or down.

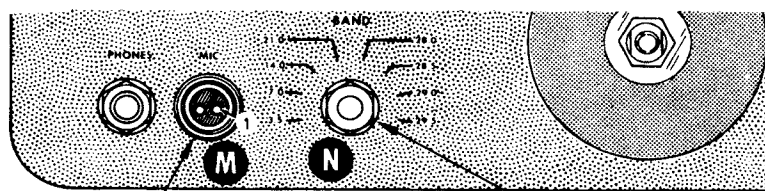

Detail 3-14B

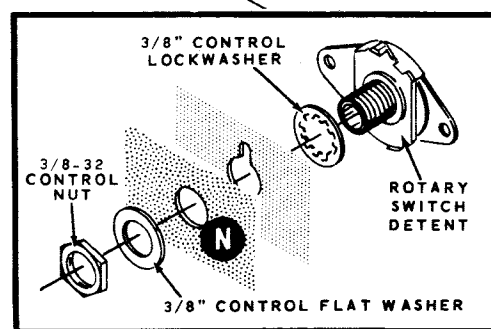
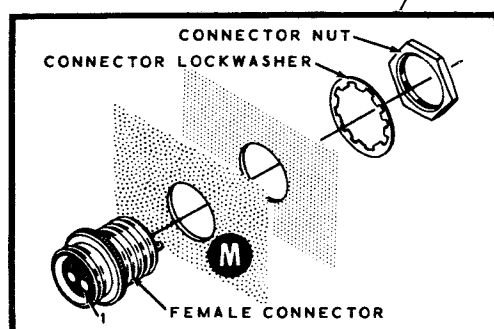

## WIRING-CHASSIS TOP

Refer to Pictorial 3-15 for the following steps.

- ( ) Plug the phono plug of the coaxial cable coming from switch J into the socket of the LMO.
- ( ) Locate the free end of the twisted wires from pilot lamp socket DG. Connect the white wire to 21 (S-1) and the brown wire to 22 (S-1) on the IF circuit board.

Refer to Detail 3-15A for the following steps.

- ( ) Bend lug 1 of a pilot lamp socket against its mounting foot and solder the two together (S-1). Be sure the other lug is not touching the mounting foot.
- ( ) Mount this pilot lamp socket at DH with 6-32 x 3/8" hardware. Position the socket as shown.
- ( ) Install a #44 pilot lamp and a pilot lamp shield at socket DH. Position the opening in the shield toward the meter.

Refer to Pictorial 3-15 for the following steps.

- ( ) Connect a 4" brown wire from lug 2 of pilot lamp socket DH (S-1) to 22 on the IF circuit board (S-1).

Connect the wire harness wires extending from cutout BY to the lugs of the LMO as follows:

- ( ) Orange-orange-white to the B+ lug (NS).
- ( ) Gray-white to the BIAS lug (NS).
- ( ) Connect a 1-1/2" brown wire from 7 on the bandpass circuit board (S-1) to the FIL lug on the LMO (NS).
- ( ) Connect a .005  $\mu$ fd disc capacitor from the BIAS lug on the LMO (S-2) to the GND lug on the LMO (NS).
- ( ) Connect a .2  $\mu$ fd resin capacitor from the FIL lug of the LMO (S-2) to the GND lug on the LMO (NS). The marked end may be in either direction.

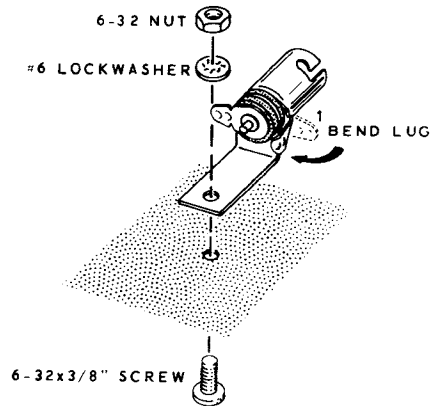

**Detail 3-15A**

- ( ) Connect a .005  $\mu$ fd disc capacitor from the B+ lug on the LMO (S-2) to the GND lug on the LMO (S-3).
- ( ) Connect a 3-1/2" black wire from Y on the bandpass circuit board (S-1) to Y on the RF-driver circuit board (S-1).
- ( ) Connect a 5-3/8" black wire from Z on the band-pass circuit board (S-1), through hole Z on the RF-driver circuit board for connection later.
- ( ) Connect a 1-3/4" black wire from W on the bandpass circuit board (S-1), to W on the audio circuit board (S-1).
- ( ) Connect a 2-1/4" black wire from X on the bandpass circuit board (S-1), to X on the audio circuit board (S-1).
- ( ) Connect the red lead of the output transformer into the RED LEAD hole in the audio circuit board (S-1).
- ( ) Connect the blue lead of the output transformer into the BLUE LEAD hole in the audio circuit board (S-1).
- ( ) Connect the free end of the black wire that comes from the variable capacitor mounted on the RF-driver circuit board, to the solder lug at DE on the RF cage (S-1). See the inset drawing on Pictorial 3-15.

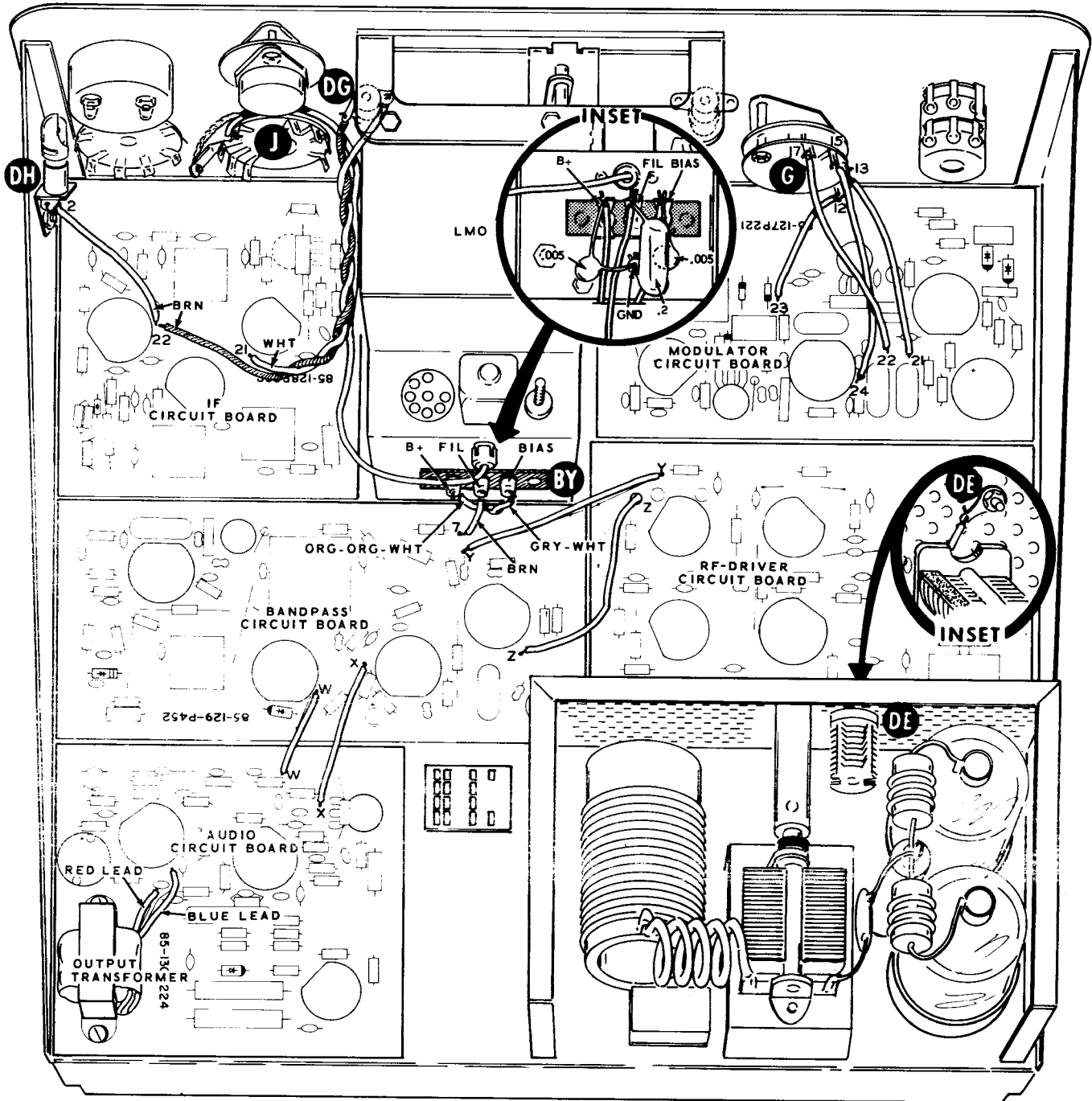

PICTORIAL 3-15

Connect the free ends of the wires coming from the lugs of switch G to the modulator circuit board as follows:

- ( ) Black from lug 12 to hole 23 (S-1).
- ( ) Black from lug 13 to hole 21 (S-1).
- ( ) Black from lug 15 to hole 24 (S-1).
- ( ) Black from lug 17 to hole 22 (S-1).

Refer to Pictorial 3-16 for the following steps.

- ( ) Refer to Detail 3-16A and mount a 1 megohm miniature control (#10-153) at S on the control bracket. Use a 1/4" control solder lug, a 1/4" control flat washer, and a 1/4-32 control nut. Position the control and solder lug as shown. Bend the control solder lug against lug 1 of the control.

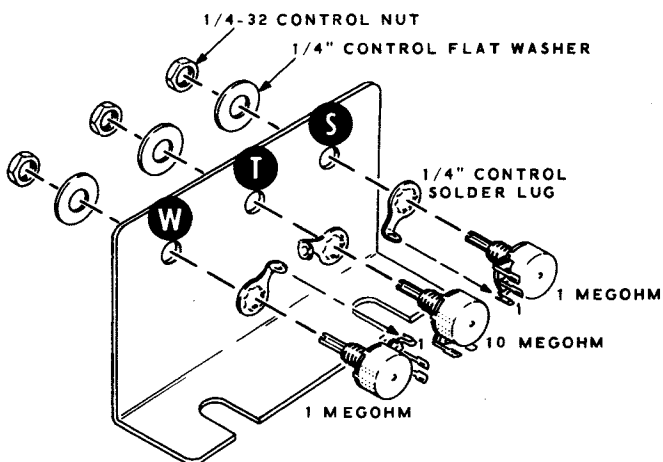

Detail 3-16A

- ( ) In a like manner, install a 10 megohm miniature control (#10-154) at T on the control bracket. Use a 1/4" control solder lug, a 1/4" control flat washer, and a 1/4-32 control nut. Position the control solder lug as shown.
- ( ) Install a 1 megohm miniature control (#10-153) at W on the control bracket. Use a 1/4" control solder lug, a 1/4" control flat washer, and a 1/4-32 control nut. Position the control and solder lug as shown. Bend the solder lug against lug 1 of the control.
- ( ) Pass one lead of a 2.2 megohm resistor (red-red-green) through lug 3 (S-2) to lug 2 (S-1) of control T. Connect the other lead of the resistor to the solder lug mounted with the control (S-1).

Connect the cables from BO#12 of the coaxial cable harness to the controls on the control bracket as follows:

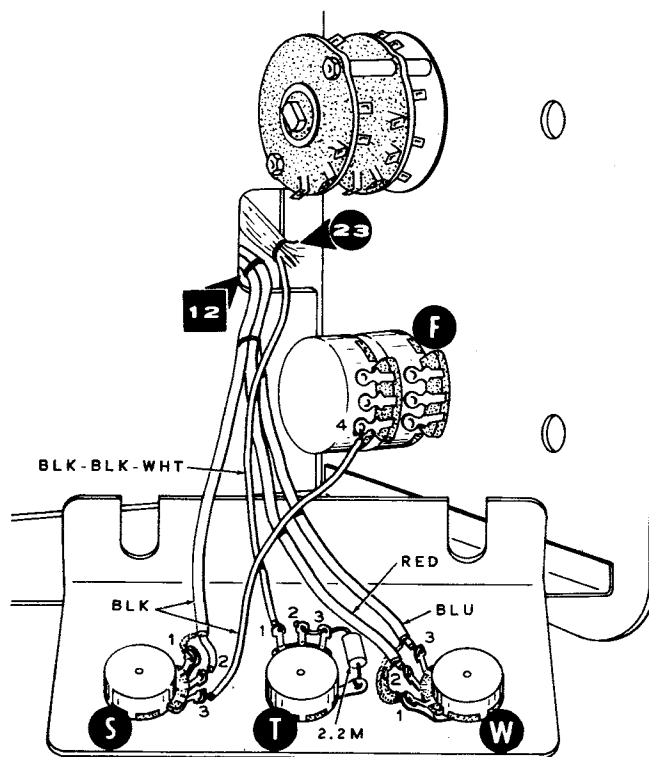

PICTORIAL 3-16

- ( ) Black: inner lead to lug 2 (S-1) and the shield to lug 1 (S-1) of control S. Be sure the solder lug is soldered to lug 1 of the control.
- ( ) Blue: inner lead to lug 3 (S-1) and the shield to lug 1 (NS) of control W.
- ( ) Red: inner lead to lug 2 (S-1) and the shield to lug 1 (S-2) of control W. Be sure the solder lug is soldered to lug 1 of the control.
- ( ) Connect the black wire coming from lug 4 of dual control F to lug 3 of control S (S-1).
- ( ) Connect the black-black-white wire from BO#23 of the wire harness to lug 1 of control T (S-1).

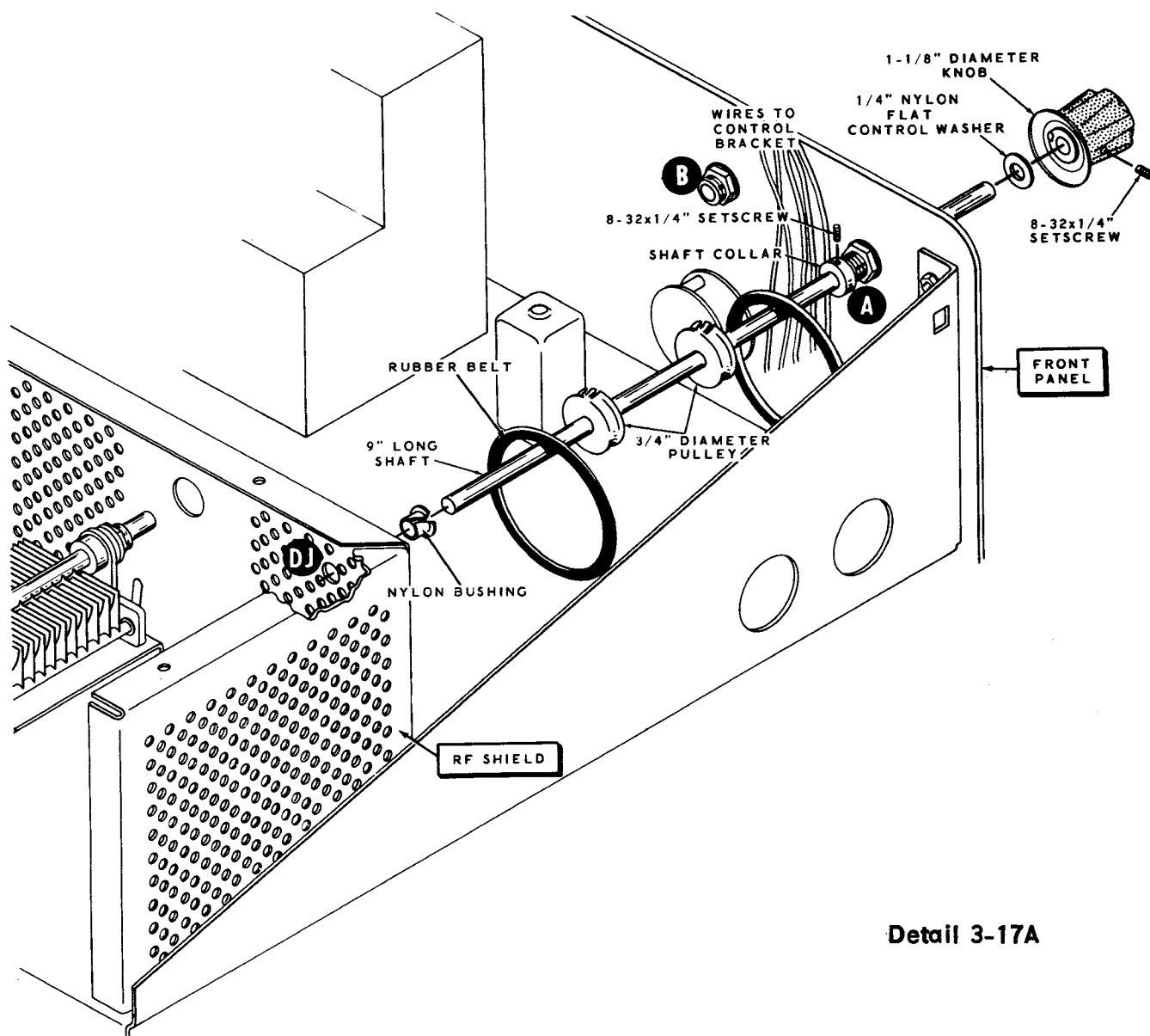

Detail 3-17A

Refer to Detail 3-17A for the following steps.

NOTE: Position the wires to the control bracket between bushings A and B before installing the shafts as follows:

- ( ) Install a nylon bushing at DJ in the RF cage.
- ( ) Install a 1-1/8" diameter knob on one end of the 9" shaft. Use an 8-32 x 1/4" setscrew.
- ( ) Place a 1/4" nylon flat control washer on the end of this 9" shaft, and pass the end of the shaft through the bushing at A in the front panel.
- ( ) Start an 8-32 x 1/4" setscrew in a shaft collar, and slide the shaft collar on the 9" shaft.
- ( ) Slide two 3/4" diameter pulleys on this shaft. Be sure the open sides of the pulleys are positioned as shown.
- ( ) Place two rubber belts over the shaft.
- ( ) Now, insert the end of this shaft into the nylon bushing at DJ. With the end of the shaft flush with the inside edge of the nylon bushing, push the shaft collar against the inside of the bushing at A on the front panel. Tighten the setscrew.

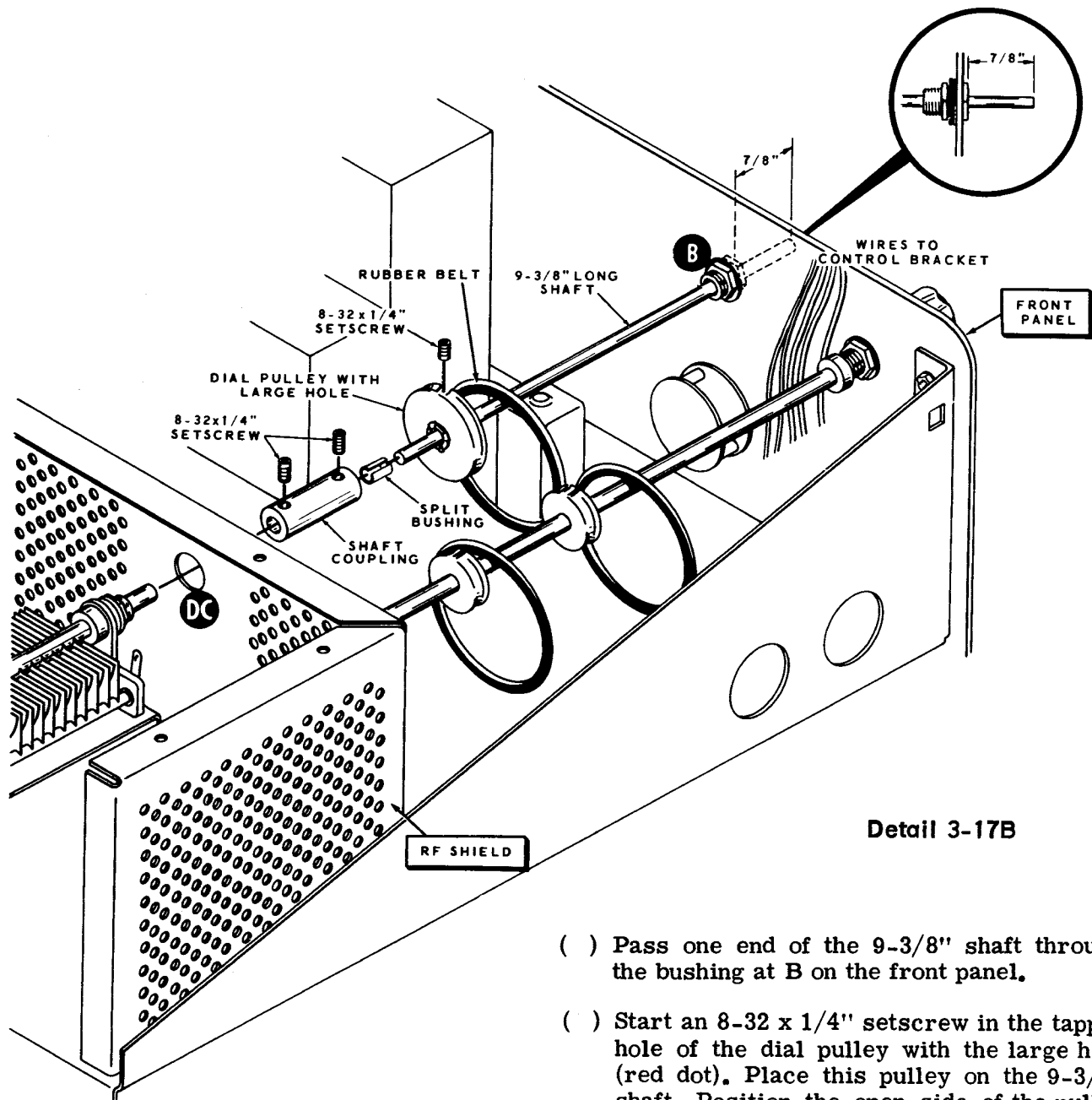

Detail 3-17B

Refer to Detail 3-17B for the following steps.

- ( ) Push a shaft coupling on the shaft of capacitor DC. Position the shaft coupling so the front setscrew hole is just outside the RF cage.
- ( ) Install a split bushing in the open end of the shaft coupling.
- ( ) Pass one end of the 9-3/8" shaft through the bushing at B on the front panel.
- ( ) Start an 8-32 x 1/4" setscrew in the tapped hole of the dial pulley with the large hole (red dot). Place this pulley on the 9-3/8" shaft. Position the open side of the pulley as shown.
- ( ) Place a rubber belt over the shaft.
- ( ) Insert the end of the 9-3/8" shaft into the shaft coupling until the other end of the shaft extends 7/8" from the front of the panel bushing.
- ( ) Install two 8-32 x 1/4" setscrews in the shaft coupling. Carefully tighten the setscrews.

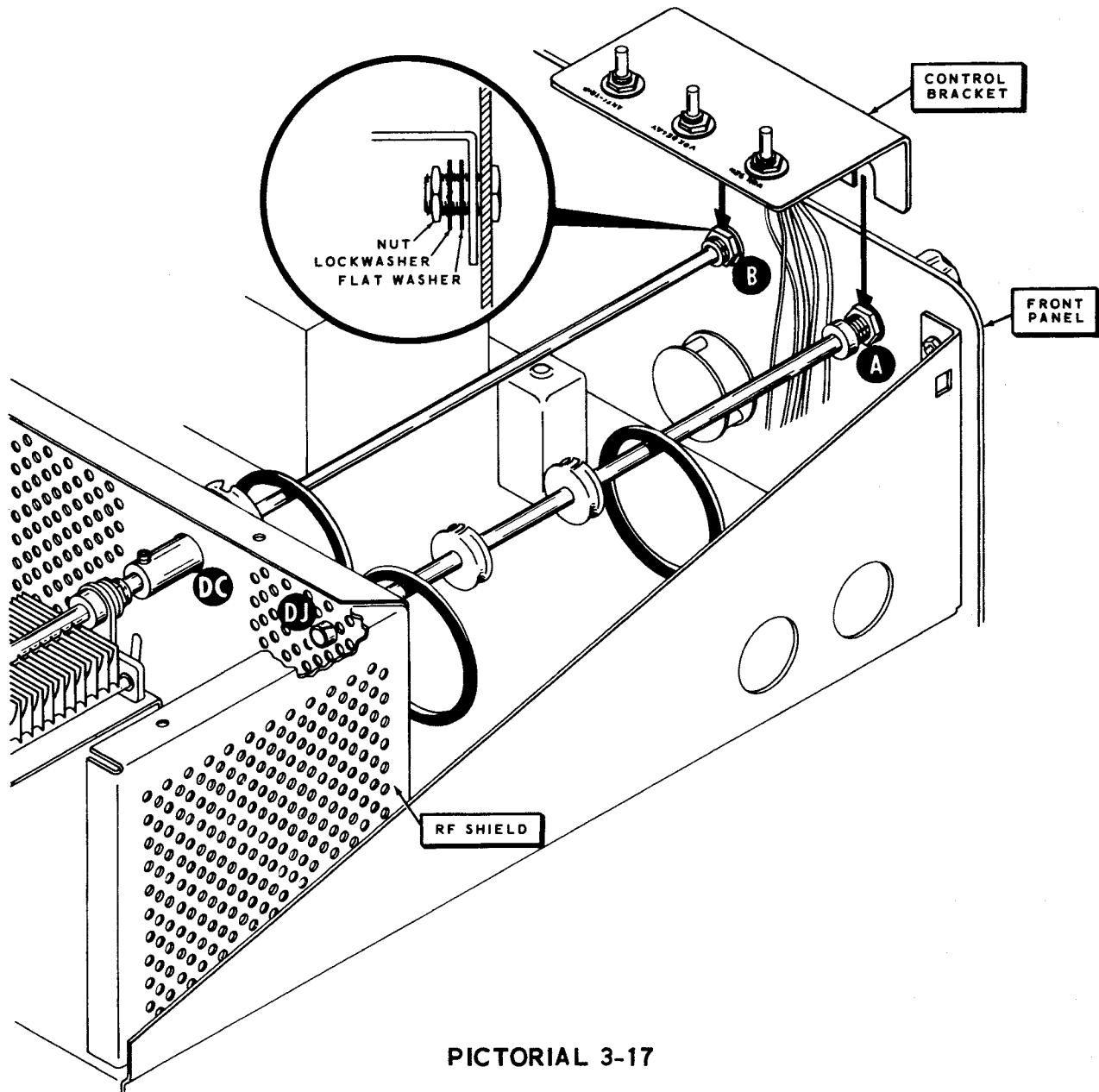

PICTORIAL 3-17

Refer to Pictorial 3-17 for the following steps.

- ( ) Temporarily remove the knob and nylon washer from the shaft at bushing A.
- ( ) Position the slots of the control bracket over the bushings at A and B. Tighten the bushing

hardware to hold the control bracket in place.

- ( ) Replace the knob and nylon washer on the shaft at bushing A. Be sure the shaft collar is against the inside of the bushing at A.

Refer to Pictorial 3-18 for the following steps.

- ( ) Slide the rear 3/4" diameter pulley on the shaft in bushing A until it is directly in line with the pulley on the variable capacitor mounted on the RF-driver circuit board.
- ( ) Solder the pulley to the shaft as shown in the inset drawing on Pictorial 3-18. Allow the pulley to cool before installing the rubber belt in the next step.
- ( ) Place the rubber belt, that was placed on the shaft earlier, over the lower pulley and then over the upper pulley.

Refer to Detail 3-18A for the following steps.

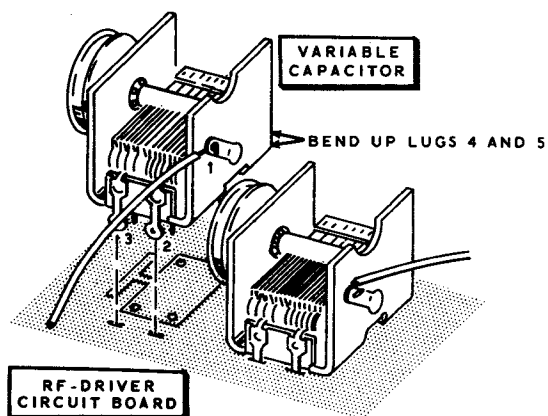

Detail 3-18A

- ( ) Remove 1/4" of insulation from only one end of a 2-1/2" black wire. Then connect this wire to lug 1 (S-1) of a two-section variable capacitor (#26-122).

NOTE: The variable capacitor may or may not have the two unused lugs that are referred to in the next step.

- ( ) If there is a lug 4 and a lug 5 on this variable capacitor, bend these lugs up tight against the capacitor insulator.

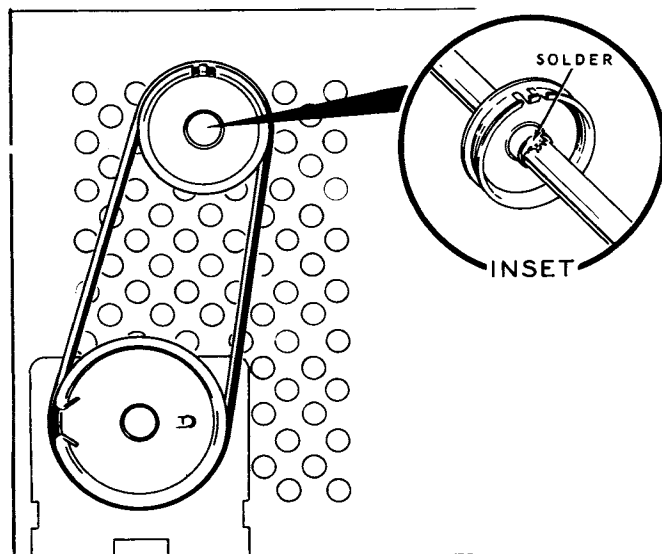

PICTORIAL 3-18

- ( ) Mount this capacitor at the forward position on the RF-driver circuit board. Solder the four pins and two lugs of the capacitor to the circuit board foil.
- ( ) Position the wire from lug 1 of this capacitor near tube socket V7. This is the neutralizing wire and its free end is left unconnected.
- ( ) Position the forward 3/4" diameter pulley, on the shaft in bushing A so it is directly in line with the pulley on the forward variable capacitor that is mounted on the RF-driver circuit board.
- ( ) Rotate the 3/4" diameter pulley so its slots are straight up, as is the other 3/4" diameter pulley. Solder this pulley to the shaft. Allow the pulley to cool before installing the rubber belt in the next step.
- ( ) Place one of the rubber belts, that were placed over the shaft earlier, over the lower pulley and then the upper pulley.



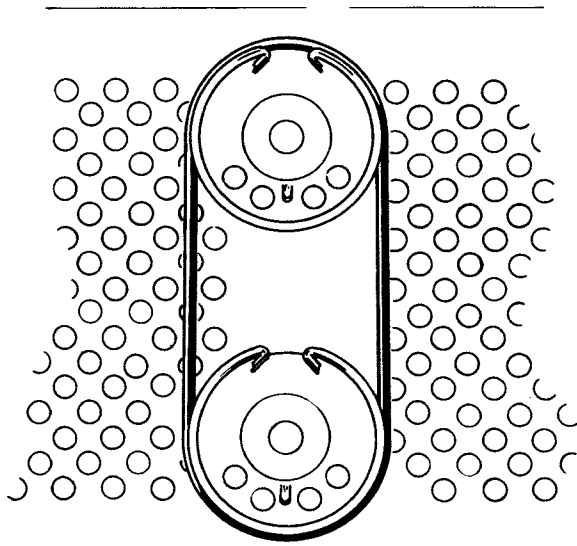

PICTORIAL 3-19

Refer to Pictorial 3-19 and Detail 3-19A for the following steps.

- ( ) Pass the unslotted end of the 8-1/4" tubular shaft over the shaft at bushing B, and into the dial pulley as shown. Use grease on the shaft where it fits into bushing B.
- ( ) Position this pulley even with the rear of the tubular shaft, and tighten the setscrew. Do not overtighten the setscrew, as this could bend the tubular shaft against the inner shaft and cause them to bind.
- ( ) Place the rubber belt, that was placed over the shaft earlier, over the lower pulley and then over the upper pulley.

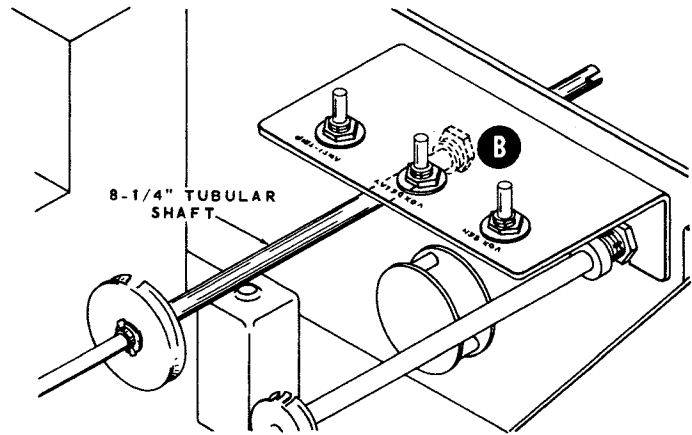

Detail 3-19A

- ( ) Install a 4PDT relay (#69-35) in each of the two relay sockets. One socket is inside the RF cage.
- ( ) Refer to Detail 3-19B and install the RF cage rear and top plates. Use #6 x 1/2" sheet metal screws. Do not use the #6 x 3/8" screws previously removed from the cage. They will be used later.

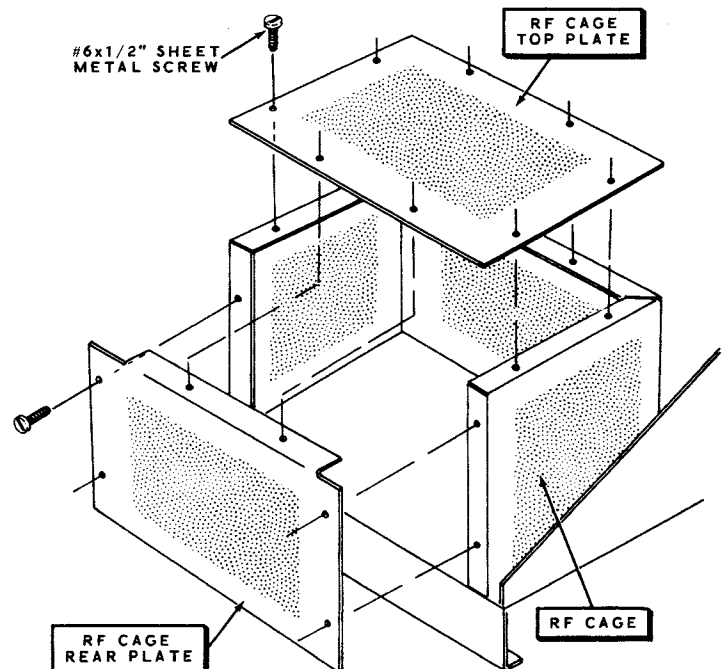

Detail 3-19B

## FINAL WIRING-CHASSIS BOTTOM

**NOTE:** Be extra careful when soldering to the circuit boards in the following steps. The driver plate, driver grid, and the heterodyne oscillator circuit boards are mounted in these steps. Best results can be obtained if the chassis is positioned so the foil side of the circuit board is horizontal. This will keep the solder from running down the board, and causing possible short circuits between the foils. Do not rest the weight of the Transceiver on the dial shafts, as this could damage the dial mechanism.

Refer to Pictorial 3-20 (fold-out from Page 73) for the following steps.

- ( ) Position the black wire extending from the RF-driver circuit board and the orange wire from grommet CB on the chassis as shown.
- ( ) Refer to Detail 3-20A and mount a comb bracket and two #3 spring clips to a support rail with 3-48 x 3/8" hardware. Position the comb bracket and spring clips as shown in the inset drawing. Bend the ends of the spring clips slightly as shown.

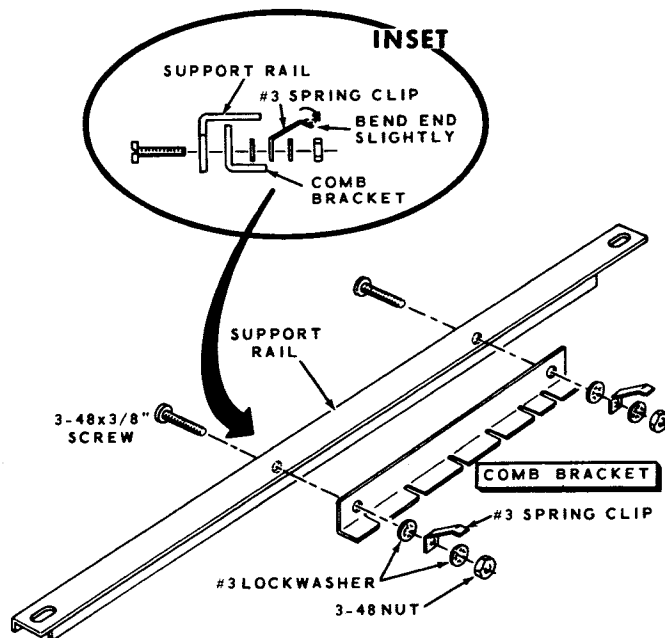

Detail 3-20A

Refer to Detail 3-20B for the following steps.

- ( ) Attach the proper end of the support rail to the rear flange of the chassis as shown. Use 6-32 x 3/8" flat head hardware. Tighten the hardware just enough to hold the support rail in place, yet permit it to swing out away from the side of the chassis.
- ( ) Swing the support rail out from the chassis.

Locate the driver plate circuit board.

- ( ) Make sure that the notch of the rotor and the color dot of the switch wafer are aligned with each other. See the inset drawing on Detail 3-20B and the lettered side of the circuit board.
- ( ) Position the driver plate circuit board in place over the RF-driver circuit board as shown. Fit the left end of the circuit board into the rear notch of the comb bracket mounted on the center shield.
- ( ) Swing the support rail back into place with the right end of the circuit board in the rear notch of the comb bracket. Do not fasten the support bracket at the front of the chassis, as it must swing out to allow the mounting of the other circuit boards.
- ( ) Locate the 11-1/4" shaft and insert the end with the two flat sides through the switch detent at N in the front panel, through the switch rotor, and into the bushing of the switch detent at BP on the RF shield. Check to see that the shaft is not binding. If necessary, loosen the nuts on the detents and adjust the detents to eliminate any binding.

Be very careful not to break the switches. It may be necessary to loosen the nut at BP and adjust the switch detent for better alignment.

Refer to Pictorial 3-20 (fold-out from Page 73) for the following steps.

Connect the coaxial cable coming from relay socket BG to the driver plate circuit board as follows:

- ( ) Inner lead to A (S-1) and the shield to B (S-1).

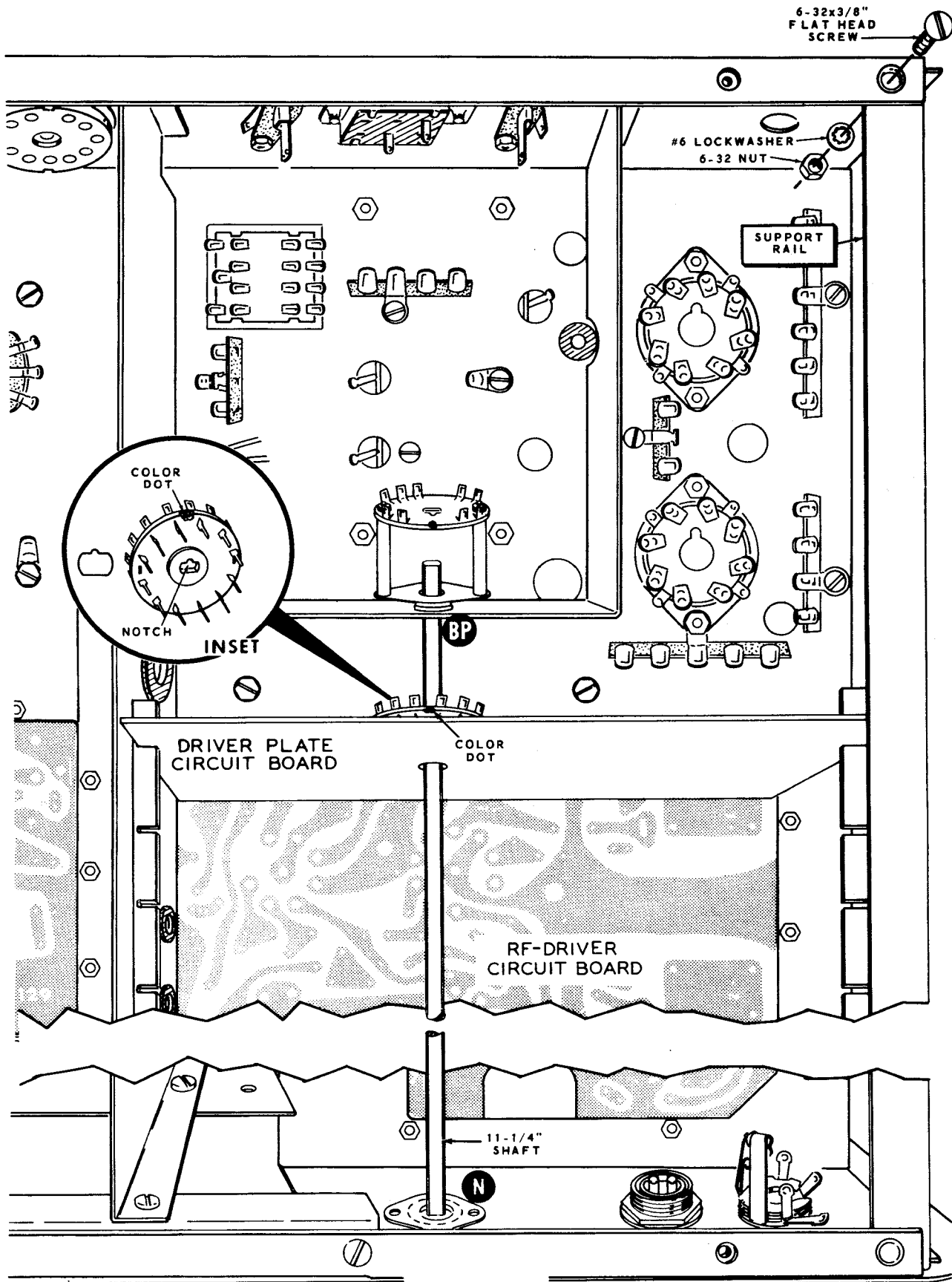

Detail 3-20B

Refer to Pictorial 3-20 for the following steps.

Connect the coaxial cable coming from the bandpass circuit board to the driver plate circuit board as follows:

- ( ) Inner lead to A (S-1) and the shield to B (S-1). Bend the switch lug at B out of the way.
- ( ) Connect the free lead of the 180 pf mica capacitor, coming from lug 1 of terminal strip BR, to 2 on the driver plate circuit board (S-1).
- ( ) Connect a 1-3/4" bare wire from 3 on the driver plate circuit board (S-1) to 3 on the RF-driver circuit board (S-1).
- ( ) Connect a 1-1/2" bare wire from 2 on the driver plate circuit board (S-1) to 7 on the RF-driver circuit board (S-1).
- ( ) Connect a 1-3/4" bare wire from 4 on the driver plate circuit board (S-1) to 1 on the RF-driver circuit board (S-1). Do not allow this wire to extend more than 1/8" through the lettered side of the RF-driver circuit board, as this would short circuit the variable capacitor mounted on top of the circuit board.
- ( ) Connect a 2-3/4" bare wire through hole 1 of the driver plate circuit board (S-2); then connect both ends of this wire at the locations shown, to the ground (outside) foil of the RF-driver circuit board. Solder both ends of the wire directly to the foil. There are no holes at these locations.

Refer to Pictorial 3-21 for the following steps.

- ( ) Remove the shaft and swing the support rail outward.
- ( ) Make sure the notch of the rotor and the color dot of the switch wafer of the driver grid circuit board are aligned with each other.
- ( ) Position the driver grid circuit board over the RF-driver circuit board as shown. Insert the left end of the circuit board into the third notch from the rear of the comb bracket that is mounted on the center shield.

- ( ) Swing the support rail back into place, with the right end of the circuit board in the correct notch of the comb bracket that is mounted on the support rail.
- ( ) Carefully install the 11-1/4" shaft as before.
- ( ) Connect a 1-3/4" bare wire from 3 on the driver grid circuit board (S-1) to 4 on the RF-driver circuit board (S-1).
- ( ) Connect a 1-1/2" bare wire from 2 on the driver grid circuit board (S-1) to 9 on the RF-driver circuit board (S-1).
- ( ) Connect a 1-1/2" bare wire from 4 on the driver grid circuit board (S-1) to 2 on the RF-driver circuit board (S-1). Do not allow this wire to extend more than 1/8" through the lettered side of the RF-driver circuit board, as this would short circuit the variable capacitor mounted on top of the circuit board.

**CAUTION:** In the next step, make sure you make this connection to the outside (ground) foil of the RF driver circuit board, and not to one of the other nearby foils.

- ( ) Connect a 1-3/4" bare wire from 1 of the driver grid circuit board (S-1) to the ground (outside) foil of the RF-driver circuit board (S-1). Solder this end of the wire directly to the foil at the indicated location. There is no hole at this location.
- ( ) Cut both leads of a 100  $\Omega$  (brown-black-brown) resistor to 1". Connect the resistor from 5 on the driver plate circuit board (S-1) to 5 on the driver grid circuit board (S-1). Position the resistor as shown to allow room for a shield that will be installed later.
- ( ) Cut both leads of a 100  $\Omega$  (brown-black-brown) resistor to 1/2". Connect this resistor between the indicated foils of the RF-driver circuit board. Solder the leads directly to the foil as there are no holes at these locations. Position the body of the resistor as shown.
- ( ) Connect the free end of the black wire, coming from 1 on the modulator circuit board, to 5 on the driver grid circuit board (S-1).

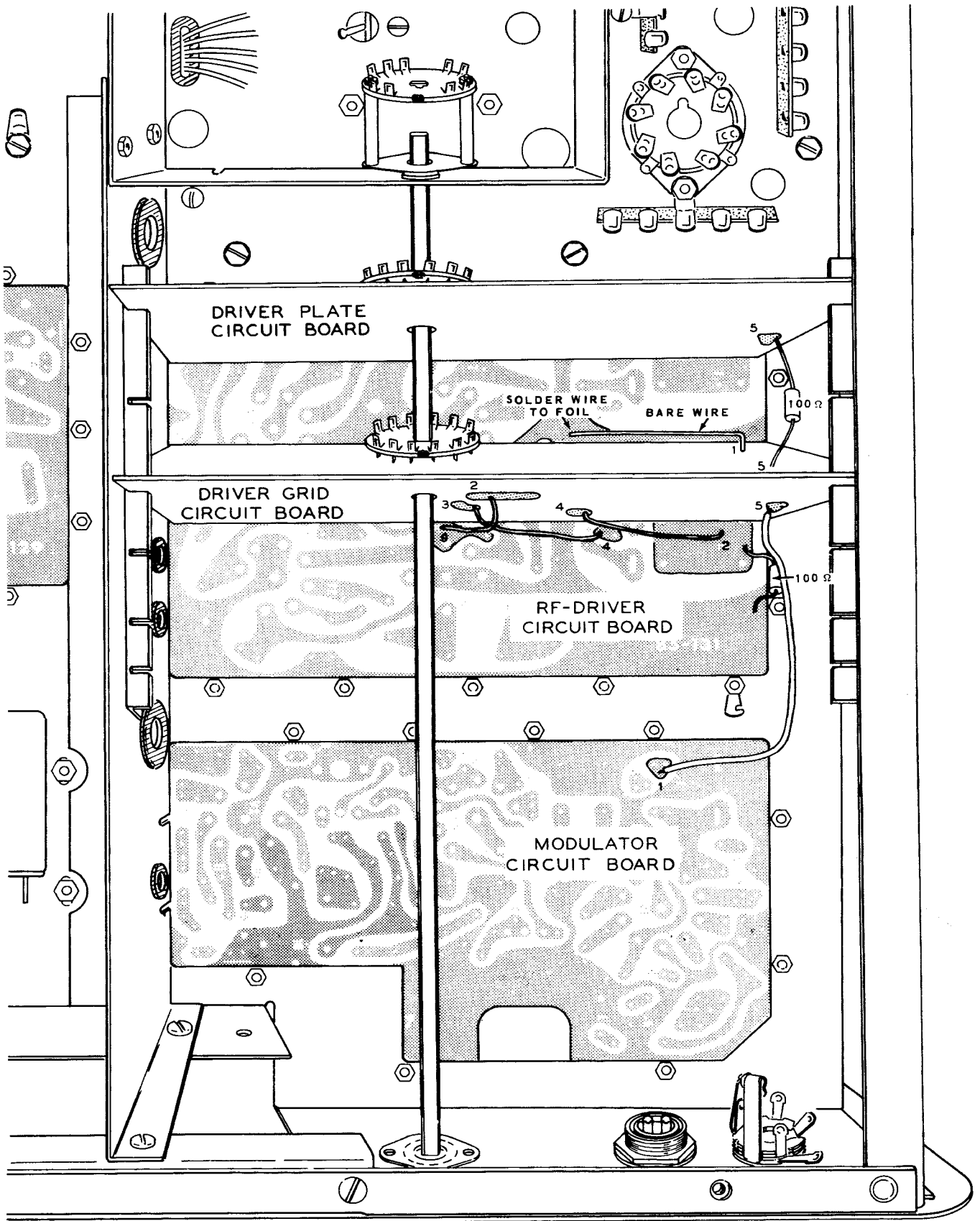

PICTORIAL 3-21

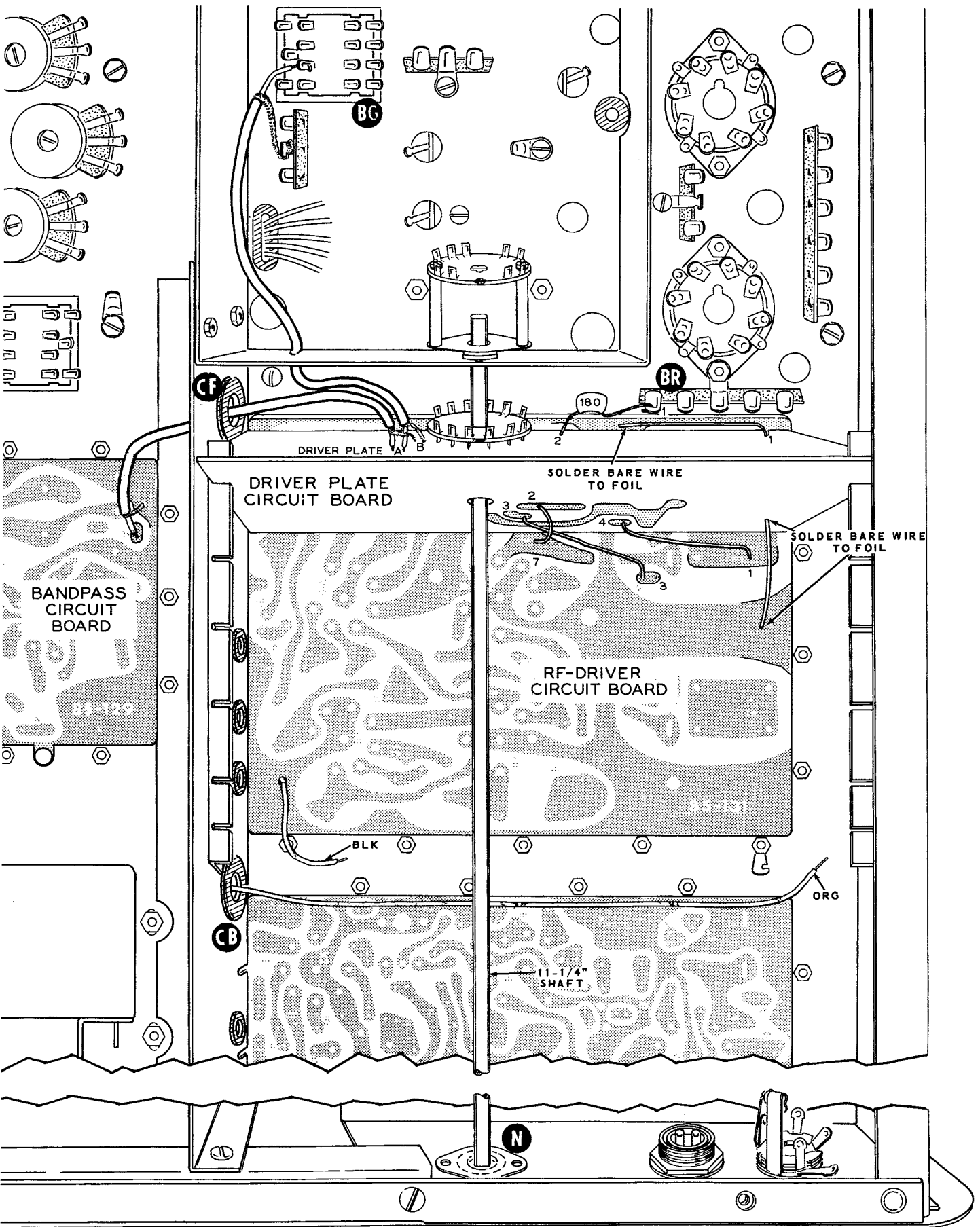

PICTORIAL 3-20

Refer to Pictorial 3-22 for the following steps.

- ( ) Remove the shaft and swing the support rail outward.
- ( ) Position the notch in the rotor of the switch wafer on the heterodyne oscillator circuit board so it is pointing away from the color dot on the switch wafer. See the inset drawing and the lettered side of the circuit board.
- ( ) Position the heterodyne oscillator circuit board over the RF-driver circuit board as shown. Insert the left end of the circuit board into the second notch from the front of the comb bracket that is mounted on the center shield. Be sure the black wire extending from the RF-driver circuit board is positioned under this circuit board as shown.
- ( ) Swing the support rail back into place, with the right end of the circuit board in the correct notch of the comb bracket mounted on the support rail.
- ( ) Carefully install the 11-1/4" long shaft as before.
- ( ) Connect the inner lead of the red coaxial cable, that has its shield connected to the center pin of tube socket V6 on the RF-driver circuit board to lug 10 of the switch wafer on the heterodyne oscillator circuit board (S-1). NOTE: Lug 10 is the long, or rotor, contact on the switch.
- ( ) Connect a 3/4" bare wire from 1 of the heterodyne oscillator circuit board (S-1), to the ground (outside) foil of the RF-driver circuit board (S-1). Solder this end of the wire directly to the foil. There is no hole at this location. At this time make sure the heterodyne oscillator is perpendicular to the chassis.
- ( ) Connect the free end of the orange wire, coming from BO#21 of the wire harness, to 5 on the heterodyne oscillator circuit board (S-1). Position the wire as shown.

Refer to Pictorial 3-23 for the following steps.

- ( ) Remove the shaft and swing the chassis support rail outward.
- ( ) Make sure the notch on the rotor and the color dot of the switch wafer of the crystal circuit board are aligned with each other.
- ( ) Position the crystal circuit board over the chassis as shown.
- ( ) Connect the free end of the black wire, extending from hole Z in the RF-driver circuit board, to 1 on the crystal circuit board (S-1).
- ( ) Insert the left end of the crystal circuit board into the front notch of the comb bracket that is mounted on the center shield.
- ( ) Swing the chassis rail back into place, with the right end of the circuit board in the correct notch of the comb bracket that is mounted on the chassis rail.
- ( ) Carefully install the 11-1/4" shaft as before.
- ( ) Place the lower right corner of the crystal circuit board against the solder lug at BT on the chassis and solder the two together (S-1). Bend solder lug BT as required to keep the circuit board perpendicular to the chassis.
- ( ) Place a 1/2" length of sleeving over the ends of both black wires from BO#1 of the wire harness. Connect both of these wires to lug 2 of connector M (S-2). After the connector has cooled, push the sleeving over the connector lug.
- ( ) Place a 1" length of sleeving on one lead of a 22 K $\Omega$  (red-red-orange) resistor. Then connect this lead to lug 1 of connector M (S-1), and connect the other lead to B on the modulator circuit board (S-1).

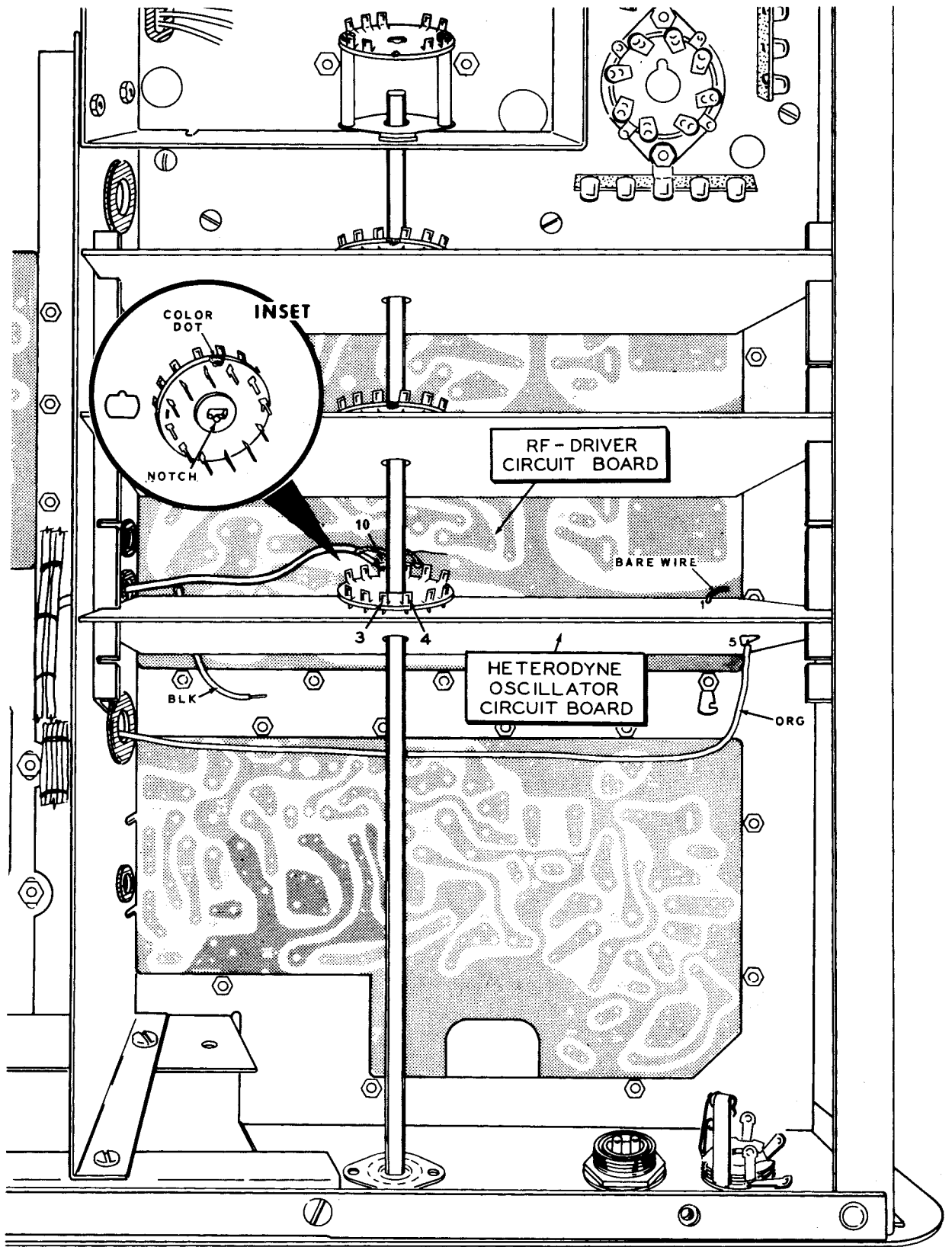

**PICTORIAL 3-22**



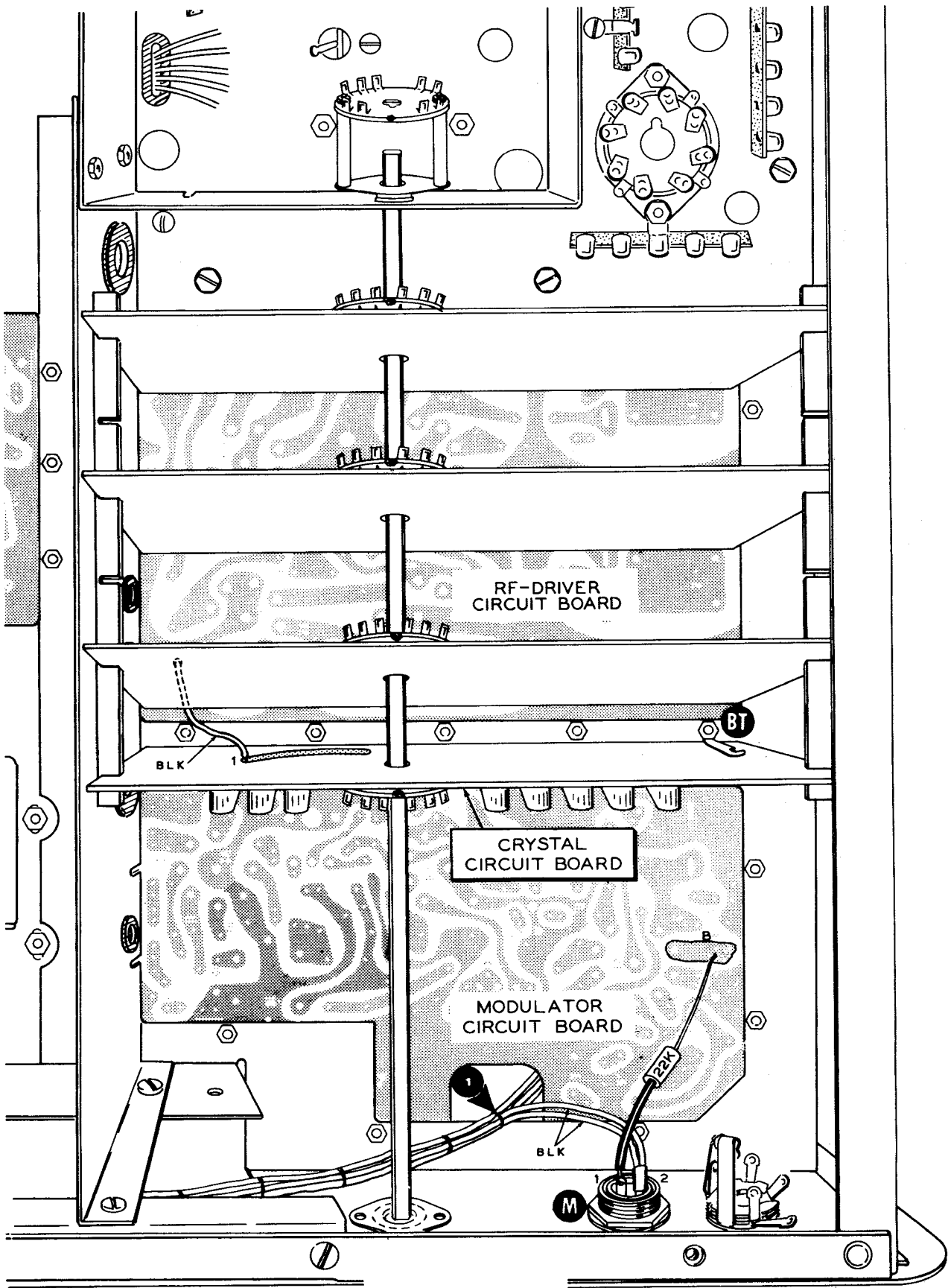

PICTORIAL 3-23

Refer to Detail 3-23A for the following steps.

- ( ) Remove the shaft and swing the support rail outward.
- ( ) Position the two switch shields into place over the RF-driver circuit board, with their left ends in the remaining slots in the comb bracket that is mounted on the center shield. Be sure the small hole in these shields is positioned in the lower right corner next to the circuit board.
- ( ) Swing the support rail back into place, with the right end of the switch shields in the correct slots of the comb bracket that is mounted on the support rail.
- ( ) Install the 11-1/4" long shaft as before. This time, be sure the small flat at the knob end faces 29.0 on the front panel. See the inset drawing on Detail 3-23A.
- ( ) Fit the two small notches in the bottom edge of the rear switch shield, so that one is on top of the center pin of tube socket V10, and the other on top of the center pin of tube socket V7. The bottom edge of the switch shield should be approximately 1/8" above the RF-driver circuit board, with the center hole of the switch shield centered around the shaft.

- ( ) Solder the switch shield to the center pins of tube sockets V10 (S-1) and V7 (S-1).
- ( ) Connect a 1" bare wire from the hole in the lower right corner of the rear switch shield (S-1) to the ground (outside) foil of the RF-driver circuit board (S-1). Solder this end of the wire directly to the foil. There is no hole at this location.

- ( ) Fit the two small notches in the bottom edge of the front switch shield, so that one is on top of the center pin of tube socket V11, and the other on top of the center pin of tube socket V6. The bottom edge of the switch shield should be approximately 1/8" above the RF-driver circuit board, with the center hole of the switch shield centered around the shaft.
- ( ) Solder the switch shield to the center pins of tube socket V11 (S-1) and V6 (S-1).
- ( ) Connect a 3/4" bare wire from the hole in the lower right corner of the front switch shield (S-1) to the ground (outside) foil of the RF-driver circuit board (S-1). Solder this end of the wire directly to the foil. There is no hole at this location.

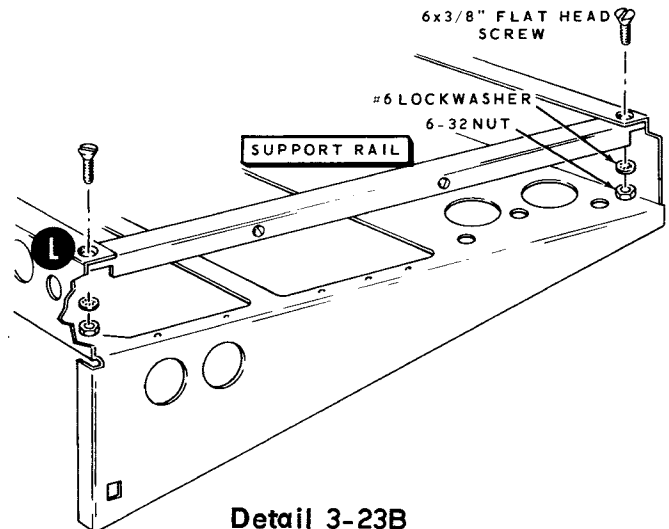

- ( ) Refer to Detail 3-23B and secure the front of the support rail to the front flange of the chassis. Use 6-32 x 3/8" flat head hardware. Tighten the hardware at the rear of this support rail. Be sure the front screw clears the lugs of the phone jack at L.
- ( ) Install a support rail at the other side of the chassis using 6-32 x 3/8" flat head hardware.

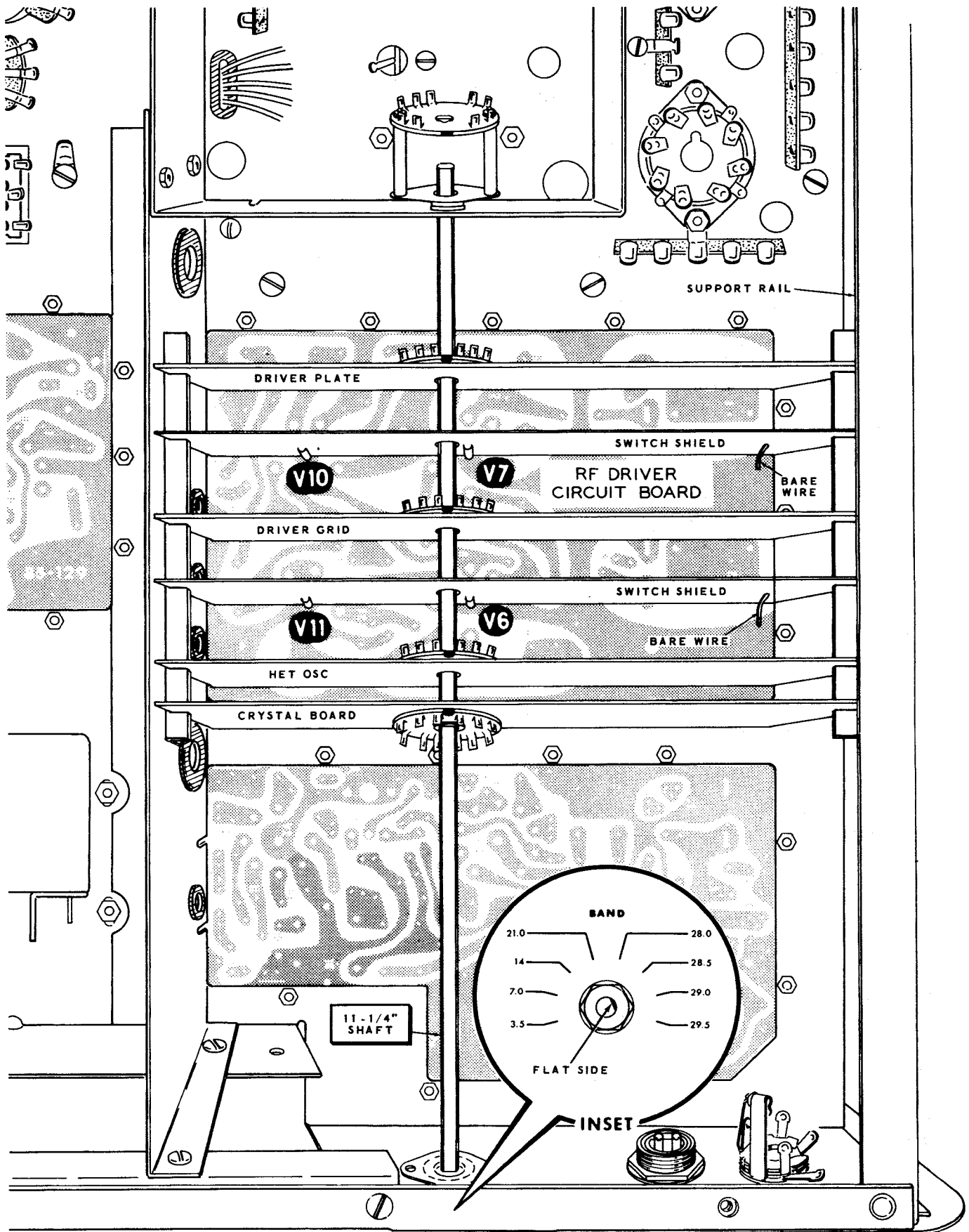

Detail 3-23A

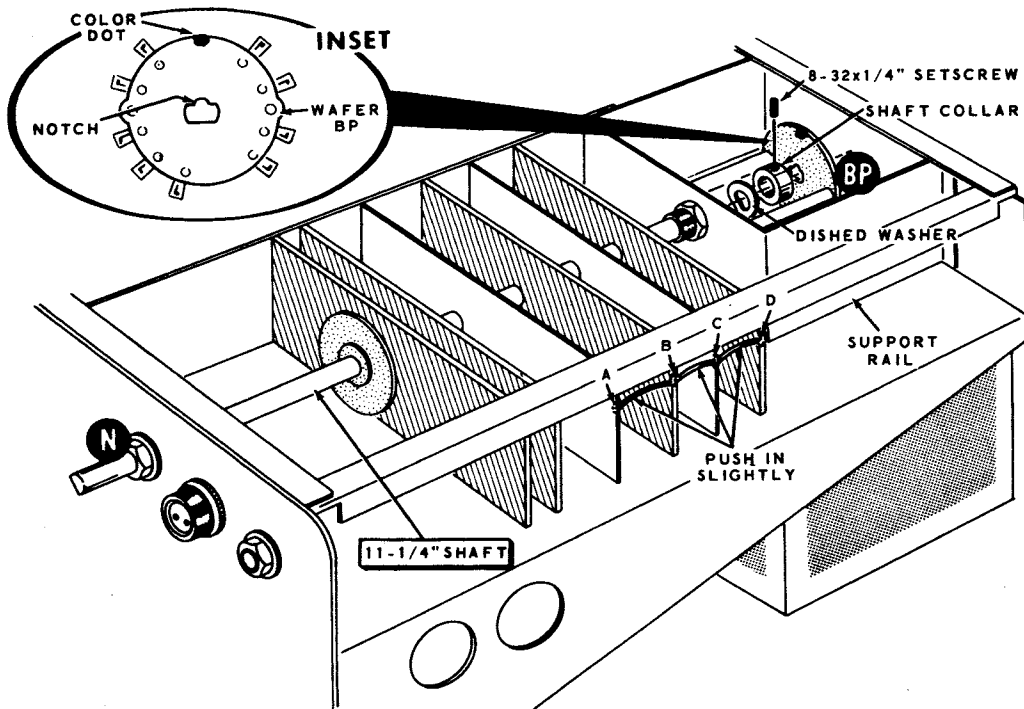

Detail 3-23C

Refer to Detail 3-23C for the following steps.

- ( ) Pull the 11-1/4" shaft out about an inch.
- ( ) Place a small amount of silicone grease around the shaft holes in switch detents BP and N.
- ( ) Push the shaft so the end near the rear of the chassis fits through the switch detent, but not into the rear section of the switch.
- ( ) Start an 8-32 x 1/4" setscrew in a shaft collar.
- ( ) Place a dished washer and the shaft collar over the end of the shaft.
- ( ) Make sure that the notch of the rotor and color dot of the switch wafer at BP are aligned as shown in the inset drawing of Detail 3-23C.
- ( ) Push the shaft in as far as possible, carefully fitting it through the rotor switch BP.
- ( ) Push the shaft collar forward, depressing the dished washer slightly against the rear of the detent, and tighten the setscrew.
- ( ) Solder a 2-3/4" small bare wire between shield A, the ground foil of circuit board B, shield C, and the ground foil of circuit board D. Position the wire approximately 1/2" away from the support rail. Before soldering, push on the wire slightly at the places shown in Detail 3-23C. This will make it easier to solder the wire to the foils and shields.

This completes the wiring of the Transceiver. Check it very carefully to see that all connections are soldered, and that no solder bridges exist between the foils of the circuit boards. Also see that the bare wires connected from the driver plate and driver grid circuit boards to the RF-driver circuit boards are not touching each other or other foils of the circuit boards. Shake out any wire clippings or solder splashes.

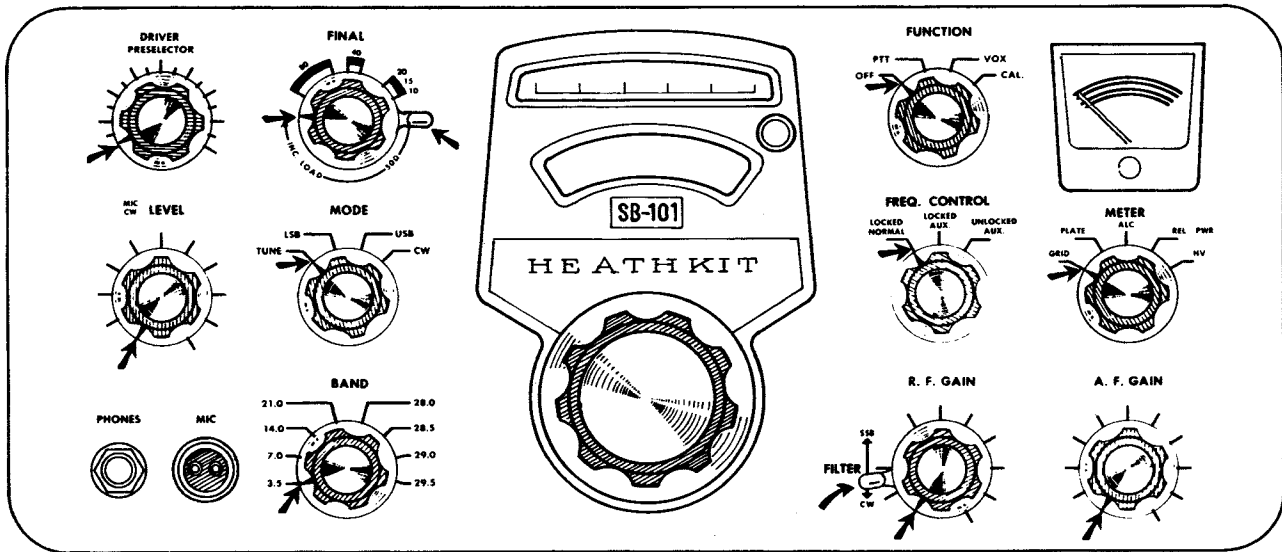

PICTORIAL 3-24

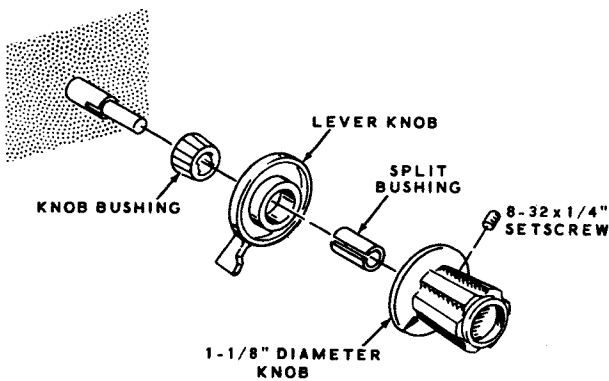

Detail 3-24A

Refer to Pictorial 3-24 for the following steps.

- ( ) Turn all switch and control shafts fully counterclockwise.
- ( ) Turn all variable capacitor shafts (extending from the front panel) so that the plates of the capacitors are fully meshed (closed).
- ( ) Start 8-32 x 1/4" setscrews in all the round knobs. There are two setscrews in the 2-1/2" diameter knob.
- ( ) Install the 2-1/2" diameter knob on the shaft of the LMO and tighten the setscrews.

- ( ) Refer to Detail 3-24A and install knob bushings on the tubular shafts at the FINAL and FILTER locations. Position each lever as indicated by the arrow and push the lever knobs on the bushings.

- ( ) Install 1-1/8" diameter knobs and split bushings on the small shafts at the FINAL and RF GAIN locations. Position the pointer on the knob as indicated by the arrow. Refer to Detail 3-24A.

Refer to Pictorial 3-24 for the following steps.

- ( ) If the pointer on the knob at the DRIVER PRESELECTOR location is not positioned as indicated by the arrow, turn the knob until the capacitors hit the stop and then continue to turn the knob. The belts on the pulleys will slip to allow knob setting. This also will assure that the capacitors are both against their stops and will track with each other.
- ( ) Install the 1-1/8" diameter knobs on the remaining front panel knob locations. Position the pointers on the knobs as indicated by the arrows. Tighten the setscrews.
- ( ) Locate the SB-101 label and remove the protective backing. Position the label and press it firmly in place in the dial es-cutcheon.

## CONTROL FUNCTIONS

The functions of the front panel and chassis controls are outlined in this section. Read the following paragraphs carefully, so you will be familiar with the operation of each control before starting to check, align, or operate this Transceiver.

### FRONT PANEL FUNCTIONS

#### Driver Preselector

This control is used to peak the receiver RF amplifier and transmitter driver tuned circuits. The adjustment can be made in either the receive or transmit mode of operation, and must be adjusted at each position of the BAND switch. This adjustment should also be made when the operating frequency is changed appreciably.

#### Mic/CW Level

When the MODE switch is in the LSB or USB position, this control is used to adjust the audio drive. The control has range enough to adjust for most high level crystal microphones or dynamic microphones.

With the MODE switch in the Tune or CW position, the carrier output level of the transmitter is adjusted with this control.

#### Phones

High impedance headphones can be connected to this jack. When the headphone plug is inserted, the speaker is disconnected from the circuit.

#### Mic (Microphone)

A high-impedance microphone should be connected to this socket. Provisions are made in the socket for connecting a microphone with a push-to-talk switch.

#### Final

The round knob is the FINAL tuning control, and the panel markings are for the 80-meter through 10-meter bands. After the Main Tuning control has been set to the desired operating frequency, and the MODE switch set to the TUNE position, this control is adjusted for maximum (Relative Power) meter indication to tune the transmitter for maximum output.

The lever arm is the FINAL loading control. It is also tuned for a maximum (Relative Power) meter indication. At this point, there is a proper impedance match between the final amplifier circuit and the antenna.

The FINAL Tuning and FINAL loading controls have some interaction and must be adjusted alternately until maximum relative power is achieved.

#### Mode

This switch selects the LSB, USB, or CW mode of operation for the receive and transmit sections. In the TUNE position, the transmitter is turned on so the driver and final RF stage can be tuned.

#### Band

In the first four switch positions, this switch selects the following bands: 80-meter (3.5 MHz to 4.0 MHz), 40-meter (7.0 MHz to 7.5 MHz), 20-meter (14.0 MHz to 14.5 MHz), and 15-meter (21.0 MHz to 21.5 MHz).

The following 500 kHz portions of the 10-meter band are selected in the other four positions of this switch: 28.0 MHz to 28.5 MHz, 28.5 MHz to 29.0 MHz, 29.0 MHz to 29.5 MHz, and 29.5 MHz to 30.0 MHz.

#### Filter Switch

This switch selects either the SSB crystal filter or, if installed, the accessory CW crystal filter.

#### Main Tuning

The Main Tuning (LMO) has two dials; the lower (circular) and upper (straight) dials.

The lower or circular dial is divided into one-hundred 1 kHz segments. The upper or straight dial is numbered from 0 to 5, and is divided into five 100 kHz segments. The distance between any two consecutive numbers is equal to 100 kHz or one revolution of the circular dial. Each large segment is divided into two 50 kHz segments, each equal to one-half of a revolution of the circular dial.

The frequency setting of the Main Tuning dial is determined by adding three numbers together as follows: the BAND switch setting in megahertz, the upper dial setting in hundreds of kilohertz, and the circular dial setting in kilohertz.

**Example #1**

BAND switch set at 7.0	7.0 MHz
Upper dial pointer between 2 and 3	200 kHz
Circular dial pointer at 26	26 kHz
Transceiver frequency	7.226 MHz

**Example #2**

BAND switch set at 28.5	28.5 MHz
Upper dial pointer between 3 and 4	300 kHz
Circular dial pointer at 74	74 kHz
	28.874 MHz

**Zero Set Dial**

This control adjusts the position of the zero set line when the dial is calibrated. First, the Main Tuning control is adjusted for a zero beat with the 100 kHz calibrate signal. Then the Zero Set knob is turned until the zero set line is over the zero mark on the circular dial. The Zero Set Dial should be adjusted at each new setting of the BAND switch. NOTE: On the higher bands, extra signals may be heard in the CAL position. The correct ones should be quite near "0", and can be peaked with the DRIVER PRESELECTOR.

**Function**

This switch turns the Transceiver OFF, or turns it on when set at the PTT (push-to-talk), VOX (voice-operated-transmit), or CAL (calibrate) positions.

In the PTT position, the Transceiver is changed from receive to transmit operation by using a push-to-talk microphone switch, or a CW key. The MODE switch must be set at LSB or USB for push-to-talk operation, or at CW when using a CW key.

In the VOX position, the Transceiver is changed from receive to transmit operation when the operator talks into the microphone, or when the CW key is depressed (depending on the MODE switch position).

In the CAL position, the 100 kHz crystal oscillator signal is turned on to calibrate the Main Tuning dial at 100 kHz intervals.

**FREQ CONTROL**

At the LMO position of this switch, the receiver and transmitter operating frequencies are determined by the linear master oscillator. The linear master oscillator frequency is determined by the setting of the Main Tuning control.

In the LOCKED AUX position, the auxiliary crystal and crystal oscillator tube V5B determine the receiver and transmitter operating frequency.

in the UNLOCKED AUX position, the auxiliary crystal and crystal oscillator tube V5B determine only the transmitter frequency. The receiver frequency is set with the Main Tuning (LMO) control.

**RF Gain**

The receiver sensitivity is controlled by the RF GAIN control. This control is set at the full clockwise position for maximum gain.

**Meter**

In the receive mode of operation, the METER switch is normally set at the ALC position. Then the meter is connected as an S-Meter that reads from 0 to 60 db over S-9.

In the transmit mode of operation, the METER switch selects one of the following five measurements to be read on the meter: final amplifier Grid current (0 to 1 ma), final amplifier Plate current (0 to 500 ma), Automatic Level Control, Relative (output) Power, and High Voltage on the B+ line (0 to 1000 volts DC).

**AF Gain**

The AF GAIN control adjusts the audio output in the receive mode of operation.

**CHASSIS FUNCTIONS**
**VOX Sen**

The VOX SENSitivity control adjusts the VOX relay circuit to operate at the voice level desired by the operator. When the operator talks into the microphone, the VOX relay is energized and places the transmitter "on-the-air."

### VOX Delay

This control adjusts the length of time the transmitter stays on after the operator stops talking (when the FUNCTION switch is set at VOX). Proper setting of the VOX DELAY control eliminates repeated keying of the transmitter at the beginning of each word.

### Anti-Trip

The ANTI-TRIP control adjusts the VOX circuit to keep the received signal (at the speaker) from turning on the transmitter by feedback into the microphone.

### Meter Zero

The METER ZERO control is adjusted for a zero reading on the meter in the receive mode of operation with no signal being received and with the RF GAIN control turned fully clockwise.

### Carrier Null Control

This control balances the modulator to suppress the carrier.

### Carrier Null Capacitor

The CARRIER NULL CAPACITOR is adjusted to complete the modulator balance.

### Cal Xtal

This trimmer adjusts the 100 kHz oscillator to exactly 100 kHz.

### Aux Trim

This trimmer permits the frequency of the auxiliary crystal oscillator to be adjusted a small amount.

### CW-Tone Volume

With the MODE switch set to CW and with the CW key depressed, the CW-TONE VOLUME control adjusts the CW tone to the desired monitoring level from the speaker.

### Phone VOL

The PHONE VOLUME control is adjusted to obtain the desired balance between the speaker and headphone levels.

### Bias Adjust

This control adjusts the bias voltage on the final RF amplifier tubes when the MIC/CW LEVEL control is turned fully counterclockwise.

### Relative Power

The Relative Power control adjusts the meter sensitivity when the METER switch is in the REL PWR position.

### Antenna

In the COMmon position, the built-in antenna relay switches the common receiving and transmitting antenna from the receiver to the transmitter sections.

In the RECEiver position, the receiver antenna circuit is connected to the RECEiver ANTenna jack when separate receiving and transmitting antennas are used.

Also, this switch makes it possible to use this Transceiver with a linear amplifier that does not have a built-in antenna change-over relay.

## PRELIMINARY CHECKS

Before applying power to the Transceiver, complete the preliminary checks as outlined in this section. These checks are needed to be sure there are no short circuits or open connections that would cause damage to the Transceiver components.

- ( ) Check the position of the pointer on the panel meter. If necessary, adjust the screw at the front of the meter until the pointer is on zero.



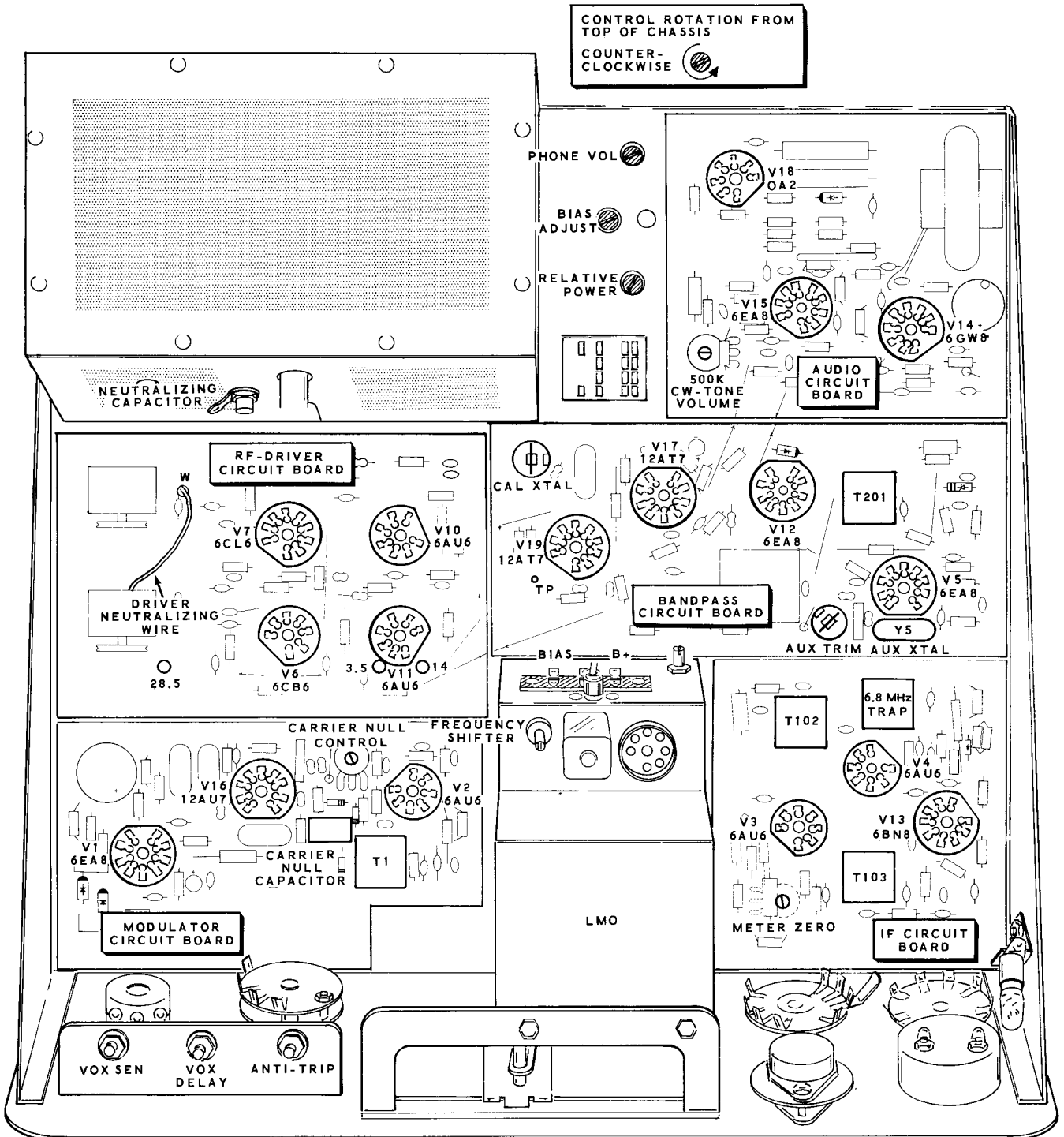

**FIGURE 1-1**

- ( ) Turn the following front panel controls to a fully counterclockwise position.

DRIVER PRESELECTOR control  
 MIC/CW LEVEL control  
 MODE switch  
 BAND switch  
 FUNCTION switch  
 FREQ control  
 RF GAIN control  
 METER switch  
 AF GAIN control  
 FILTER switch

- ( ) Set the following chassis controls to a fully counterclockwise position. Refer to Figure 1-1 (fold-out from Page 82) to help locate the controls.

VOX SEN  
 VOX DELAY  
 ANTI-TRIP  
 CARRIER NULL control  
 METER ZERO  
 CW-TONE VOLUME  
 PHONE VOL  
 BIAS ADJUST  
 RELATIVE POWER

- ( ) At the rear of the chassis, push the ANTENNA switch to the REC position.

### METER CIRCUIT CHECKS

Refer to Figure 1-2 (fold-out from Page 99) to locate the test points for the following checks.

An ohmmeter will be used for the following checks. When making the first check, the polarity of the ohmmeter test leads will be determined. Then the test points for the common and positive (+) leads will be called out in each step.

- ( ) Set the ohmmeter to the RX1 range.
- ( ) Turn the front panel METER switch to the PLATE position.
- ( ) Check the polarity of the ohmmeter leads as follows: Connect one ohmmeter lead to the Transceiver chassis and the other lead to pin 1 of tube socket V9. If an "up scale" deflection of the panel meter is not obtained, reverse the ohmmeter leads. When an "up scale" meter indication is obtained, the meter lead connected to pin 1 of tube socket V9 should be marked (+) positive. This lead should be used as the positive (+) lead for the remaining checks.

NOTE: If the correct results are not obtained in the following steps, refer to the In Case Of Difficulty section on Page 112. It is suggested that all the checks be completed before doing any troubleshooting. The resistance reading may set some pattern that will make the difficulty easier to locate.

Complete each of the following checks by connecting the ohmmeter leads as indicated. Set the METER switch and the ohmmeter range as listed in the step. For each check, the panel meter should indicate in an "up scale" direction.

METER SWITCH	OHMMETER RANGE	COMMON LEAD	POSITIVE (+) LEAD
( - ) GRID	RX10	Pin 5 of tube socket V9	Chassis
( ) ALC	RX1	Pin 7 of tube socket V3 (on IF circuit board)	Chassis
( ) REL PWR	RX1	Chassis	Lug 1 of terminal strip BH
( ) HV	RX100	Chassis	Lug 1 of terminal strip BK

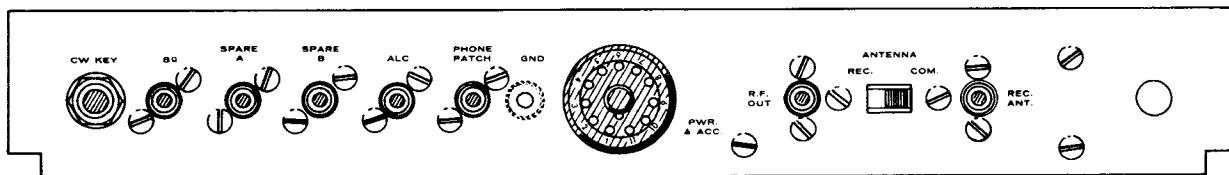

Figure 1-3

**RESISTANCE CHECKS**

Refer to Figures 1-1 (fold-out from Page 82), 1-2 (fold-out from Page 99), and 1-3 for the following resistance checks.

Complete the resistance checks listed in each of the three charts. Connect the common and positive (+) ohmmeter leads and set the switches as listed in the chart.

When more than one switch setting is given, make the resistance check at each setting of the switch. Also, observe the special instructions given in the NOTES column.

**NOTE:** If any incorrect resistance readings ( $\pm 20\%$  from the listed value) are obtained, refer to the In Case Of Difficulty section and correct the trouble before proceeding.

**IMPORTANT:** The word "Diode" in the NOTES column of the following charts indicate that a diode is in the circuit under test. Therefore, the measured resistance can vary due to the forward current of the diode, and depending on the range setting of the ohmmeter. The ohmmeter readings in the chart were made with a VTVM. Readings made with a VOM will be considerably different than those listed.

OHMMETER TEST POINTS		MODE SWITCH	RESISTANCE IN OHMS	NOTES
COMMON LEAD	POSITIVE (+) LEAD			
( ) Chassis	CW KEY jack, lug 3	CW	50K	
( ) CW KEY jack, lug 3	Chassis	"	30K	(Diode)
( ) "	"	TUNE, LSB, and USB	80K	(Diode)
( ) Chassis	8 $\Omega$ jack, lug 2	TUNE	.7	
( ) "	Spare A jack, lug 2	"	INF	
( ) "	Spare B jack, lug 2	"	INF	
( ) "	ALC jack, lug 2	"	5 to 20	(Diode)
( ) ALC jack, lug 2	Chassis	TUNE and CW	10K to 500	(Diode) Varies with setting of MIC/CW LEVEL control.
( ) "	"	LSB and USB	1M to 3M	(Diode)
( ) Chassis	Phone Patch jack, lug 2	TUNE	1M	
( ) "	Power plug Pin 1	"	13K	
( ) "	" Pin 2	"	0	

OHMMETER TEST POINTS		MODE SWITCH	RESISTANCE IN OHMS	NOTES
COMMON LEAD	POSITIVE (+) LEAD			
( ) Chassis	Power plug, Pin 3	TUNE, LSB, USB, CW	35K	
( ) "	Power plug, Pin 4	TUNE	1M	
( ) "	" Pin 5	"	INF	
( ) "	" Pin 6	"	1	
( ) "	" Pin 7	"	0	
( ) "	" Pin 8	"	INF	
( ) "	" Pin 9	"	INF	
( ) "	" Pin 10	"	INF	
( ) "	" Pin 11	"	INF	
( ) Power Plug, Pin 9	" Pin 10	"	INF	
( ) " "	" "	"	0	Check at three positions of FUNCTION switch: PTT, VOX and CAL. Then return the FUNCTION switch to the OFF position.
( ) Chassis	RF OUT jack, lug 2	"	INF	
( ) "	"	"	.2	Check with ANT switch at COM.
( ) "	REC ANT jack, lug 1	"	.2	
( ) "	PHONES jack, contact 5	"	.2 to 2000 to 3	Varies with setting of PHONE VOL control.
( ) "	MIC socket, lug 1	"	1M	
( ) "	" lug 2	"	0	
( ) "	" "	LSB, USB, and CW	500K	
( ) "	RF GAIN control, lug 2	TUNE	70K to 10	Varies with setting of RF GAIN control.
( ) "	AF GAIN control, lug 2	"	0 to 500K	Varies with setting of AF GAIN control.

OHMMETER TEST POINTS		BAND SWITCH	RESISTANCE IN OHMS
COMMON LEAD	POSITIVE (+) LEAD		
( ) Chassis	Capacitor lug DB-1	3.5 and 7.0	11K
( ) "	" " "	14.0 through 29.5	INF
	<u>CIRCUIT BOARD LOCATION</u>		
( ) Power Plug, Pin 3	RF DRIVER Foil 7	3.5	100
( ) "	" 3	"	100
( ) "	" 3	7.0 through 29.5	22K
( ) "	" 9	3.5	1000
( ) "	" 4	"	1000
( ) "	" 4	7.0 through 29.5	INF
( ) Chassis	Lug 1 (Wafer BS1 of BAND switch)	3.5	4700
( ) "	"	7.0 through 29.5	INF
( ) "	Audio 22 Circuit Board	3.5	35K
( ) Audio Circuit Board 22	Bandpass Circuit Board B	All Positions	100

OHMMETER TEST POINTS			MODE SWITCH	FREQUENCY CONTROL SWITCH	RESISTANCE IN OHMS	NOTES
COMMON LEAD	POSITIVE (+) LEAD					
( ) Chassis	CIRCUIT BOARD	LOC.	TUNE	LOCKED NORMAL and UNLOCKED AUX	.3	
	Bandpass	H				
( ) "	"	H	"	LOCKED AUX	INF	
( ) "	"	F	"	LOCKED NORMAL	100	
( ) "	"	F	"	LOCKED AUX and UNLOCKED AUX	INF	
( ) "	"	G	"	LOCKED NORMAL	INF	
( ) "	"	J	"	"	150K	
( ) Audio Circuit Board 22	"	19	"	LOCKED NORMAL and UNLOCKED AUX	INF	
( ) " 22	"	19	"	LOCKED AUX	0	
( ) " 22	B+ (terminal board at rear of LMO)		"	"	INF	
( ) " 22	"		"	LOCKED NORMAL and UNLOCKED AUX	0	
( ) Chassis	CIRCUIT BOARD	LOC.	"	LOCKED NORMAL	35K	
	Bandpass	E				
( ) "	"	8	"	"	100K to 600K	Varies with setting of VOX SEN control.
( ) "	"	8	CW	"	0	
( ) "	"	D	TUNE, USB, LSB	"	0 to 500K	Varies with setting of VOX SEN control.
( ) "	"	"	CW	"	0 to 100K	"
( ) "	"	10	"	"	350K to 500K	Varies with setting of ANTI-TRIP control. (Diode)

OHMMETER TEST POINTS			MODE SWITCH	FREQUENCY CONTROL SWITCH	RESISTANCE IN OHMS	NOTES
COMMON LEAD	POSITIVE (+) LEAD					
( ) Chassis	<u>CIRCUIT BOARD</u> Bandpass	<u>LOC.</u> 14	TUNE	LOCKED NORMAL	2M to 12M	Varies with setting of VOX DELAY control.
( ) "	"	16	"	"	0	
( ) "	"	16	LSB, USB, and CW	"	500K	
( ) "	Bandpass	3	TUNE	LOCKED NORMAL	INF	Goes to "0" in "CAL" position of FUNCTION switch.
( ) "	"	C	"	"	35K	
( ) "	IF	B	"	"	4700	
( ) "	IF	13	"	"	100K	(Diode) Varies with setting of RF GAIN control.
( ) "	Audio	B	"	"	1M to 100K	Varies with setting of ANTI-TRIP control.
( ) "	Modulator (See top side)	21	TUNE, USB, and CW	LOCKED NORMAL	INF	
( ) "	"	21	LSB	"	100K	
( ) "	" Socket V16 Pin1		LSB	"	INF	
( ) "	" Socket V16 Pin 1		TUNE, USB, and CW	"	70K	
( ) "	"	D	TUNE	"	0 to 500K	Varies with setting of MIC/CW LEVEL control.
( ) "	BIAS (terminal board at rear of LMO)		TUNE, USB, and CW	"	7000 to 4300	Varies with setting of BIAS adjust control.
( ) "	"		LSB	"	11K	

This completes the Preliminary Checks.

### COIL COVER INSTALLATION

Refer to Pictorial 3-25 for the following steps.

- ( ) Install the eight spring clips on the coil cover with 3-48 x 3/8" hardware. Position the spring clips as shown. Bend the clip ends down slightly as shown in the inset drawing.

**CAUTION:** Be sure that none of the lugs of the switch wafers that are mounted on the driver plate, driver grid, heterodyne oscillator, and crystal circuit boards extend beyond the edges of these circuit boards.

- ( ) Refer to Detail 3-25A and mount the coil cover on the bottom of the chassis with #6 x 3/8" sheet metal screws (screws from the RF cage). Be sure the spring clips on the coil cover fit on each side of the two switch shields. Note that the edge of the coil cover must first be positioned under the support rail, before the coil cover can be positioned into place. This can be checked by looking at the ends of the circuit boards from under the support rail.

- ( ) Check the resistance between pin 3 of the power plug and the chassis. A zero resistance reading indicates a short circuit caused by the coil cover touching one or more of the switch lugs. This condition must be corrected before turning on the Transceiver.

### TUBE INSTALLATION

- ( ) Replace the tube and tube shield that were removed previously from the LMO.
- ( ) Install the remaining tubes in their sockets, as identified on the circuit boards.

Install the tube shields as follows:

- ( ) Small tube shield (1-3/4" long) at V6.
- ( ) Large tube shield (2" long) at V7.
- ( ) Large tube shield (1-3/4" long) at V1.

Refer to the Special Crystal Considerations section of the Manual on Page 98, for the crystal that may be used in the Auxiliary Crystal socket on the bandpass circuit board.

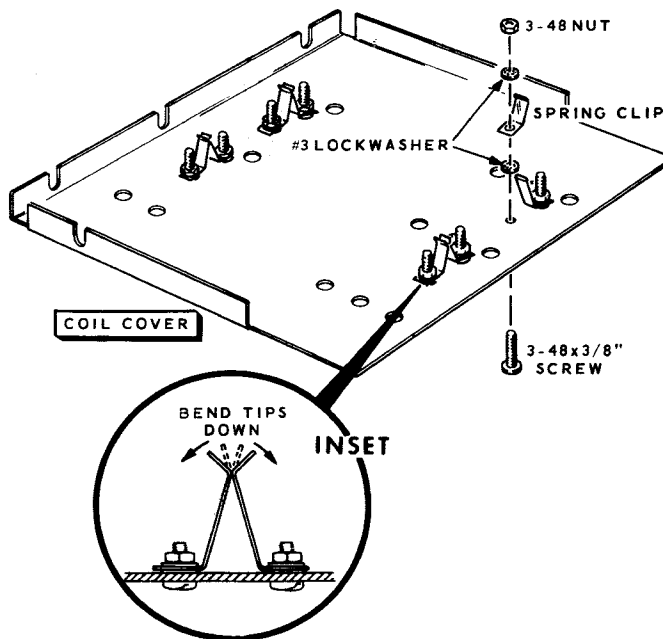

PICTORIAL 3-25

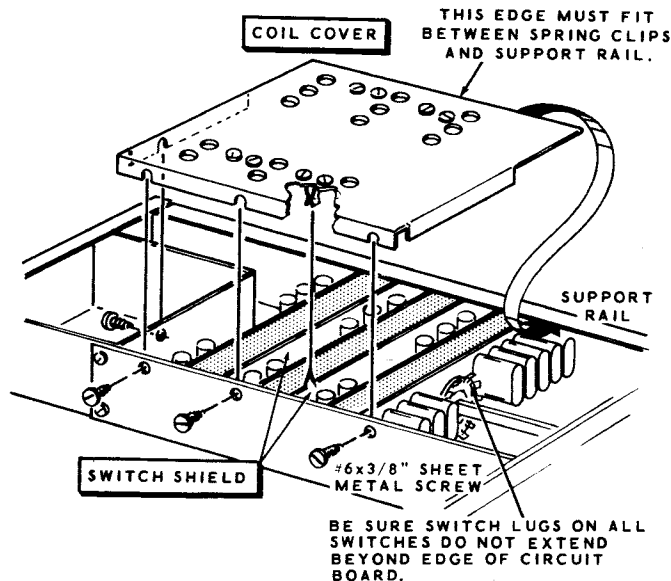

Detail 3-25A



## POWER SUPPLY CONNECTIONS

The Transceiver was designed to operate with the Heathkit Models HP-13 (12 V DC power source) and HP-23 (117 V AC power source) Power Supplies. The following information will help you wire the 11-pin socket (supplied with the Transceiver) for the power cable of the Power Supply you intend to use.

### HP-13 POWER SUPPLY CONNECTIONS

**CAUTION:** Be sure the alternate connection in the low voltage DC circuit of the HP-13 Power Supply is connected for +300 volts output as outlined in the HP-13 Manual. Be sure the automobile voltage regulator is set to less than 14.5 volts.

**NOTE:** If the Heathkit Model SBA-100-1 Mobile Mount is used, complete the power supply connections as directed in that manual.

Refer to Figure 1-4 for the following steps.

- ( ) Install the 11-pin socket cap over the free end of the 8-wire cable from the HP-13 Power Supply, as shown.
- ( ) Remove 3/4" of the outer insulation from the end of the 8-wire cable. Then remove 1/4" of insulation from the end of each wire.
- ( ) Melt a small amount of solder on each of the exposed wire ends to hold the small strands of wire together.

- ( ) Insert the lead from the cap end of the fuseholder (an in-line fuseholder with lead is supplied with the HP-13 Power Supply) through the socket cap as shown.

If the Heathkit Model HA-14 Linear Amplifier is used, a coaxial cable from the HA-14 power connector should be inserted through the socket cap as shown. Use the coaxial cable with the inner lead connected to lug 12 and the shield to lug 1 of the HA-14 power connector.

- ( ) Cut seven 5/8" lengths of large sleeving and slip them over the indicated wires.

- ( ) Connect the wires of the 8-wire cable, the fuseholder lead, and the coaxial cable (if the HA-14 Linear Amplifier is used) to the 11-pin socket lugs as shown. Solder each connection.

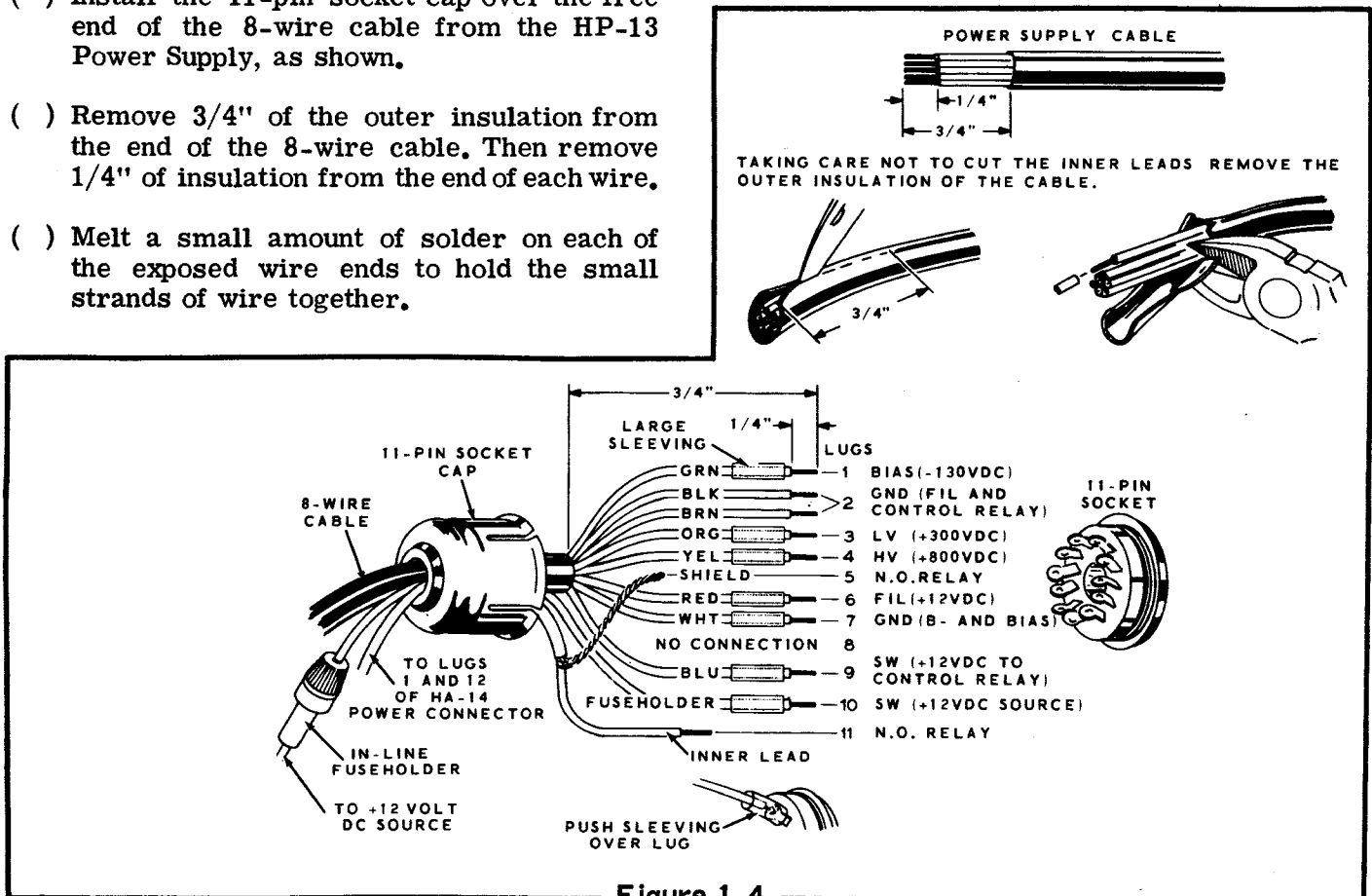

Figure 1-4

- ( ) Push the lengths of sleeving over the lugs of the socket.
- ( ) Snap the socket cap onto the 11-pin socket. **IMPORTANT:** When using the HP-13 Power Supply with the Transceiver, be sure the Bias control of the Power Supply is in its fully clockwise position. This setting will supply a maximum bias voltage at pin 9 of the power socket.

**HP-23 POWER SUPPLY CONNECTIONS**

**CAUTION:** Be sure the alternate connection in the low voltage DC circuit of the HP-23 Power Supply is connected for +300 volts DC output as outlined in the HP-23 Manual.

Refer to Figure 1-5 for the following steps.

- ( ) Install the 11-pin socket cap over the free end of the 8-wire cable from the Power Supply.
- ( ) Remove 3/4" of the outer insulation from the end of the 8-wire cable. Then remove 1/4" of insulation from the end of each wire.
- ( ) Melt a small amount of solder on each of the exposed wire ends to hold the small strands of wire together.

If the Heathkit Model HA-14 Linear Amplifier is to be used, a coaxial cable from the HA-14

power connector should be inserted through the socket cap as shown. Use the coaxial cable with the inner lead connected to lug 12 and the shield to lug 1 of the HA-14 power connector.

For the SB-200 and other Linear Amplifiers, use a piece of coaxial cable through the cap to bring out the relay connections.

- ( ) Cut seven 5/8" lengths of large sleeving and slip them over the indicated wires.
- ( ) Connect the wires of the 8-wire cable and the coaxial cable (if a Linear Amplifier is used) to the 11-pin socket lugs as shown. Solder each connection.
- ( ) Push the lengths of sleeving over the lugs of the socket.
- ( ) Snap the socket cap onto the 11-pin socket.

**NOTE:** With the above connections, the BIAS control in the HP-23 Power Supply is inoperative. Proper bias settings are accomplished with the BIAS control in the Transceiver.

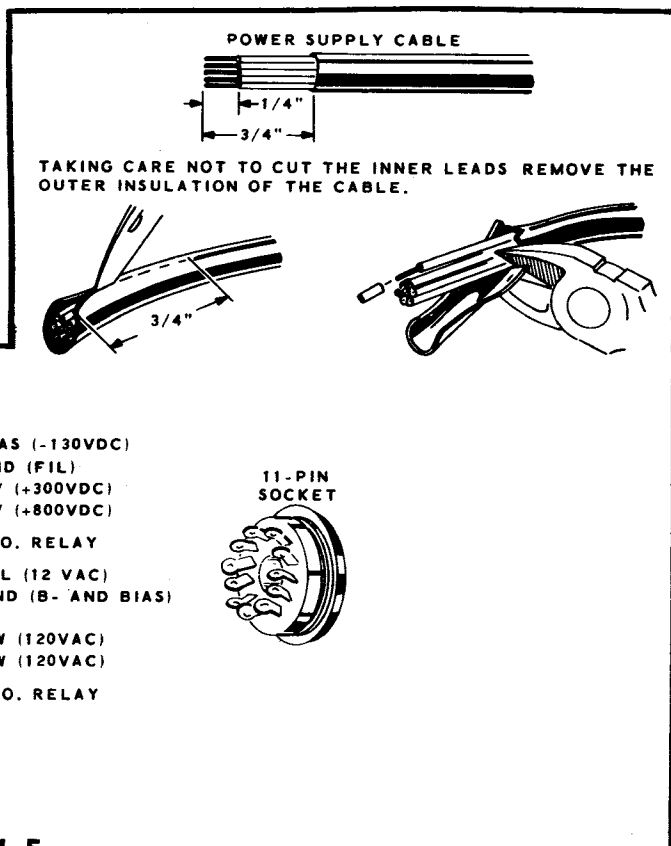

Figure 1-5

## INITIAL TEST

**CAUTION: BEFORE APPLYING POWER TO THE TRANSCEIVER, NOTE THAT LETHAL VOLTAGES ARE PRESENT BOTH ABOVE AND BELOW THE CHASSIS. DO NOT TOUCH ANY HIGH VOLTAGE POINTS WITH YOUR HANDS. USE WELL INSULATED TOOLS FOR ANY ADJUSTMENTS ON THE CHASSIS.**

**TO LESSEN THE SHOCK HAZARD, CONNECT A LEAD FROM A GOOD EARTH GROUND TO THE GROUND BOLT LOCATED ON THE REAR OF THE CHASSIS AND TO ALL TEST EQUIPMENT.**

- ( ) Set the front panel controls as follows:  
     FINAL (round knob) . . . . . to 80.  
     FINAL (lever knob) .. over the 50  $\Omega$  marking.  
     MODE. . . . . LSB.  
     RF GAIN. . . . . fully clockwise.  
     FILTER. . . . . SSB.
- ( ) Set the remaining front panel controls fully counterclockwise.
- ( ) Set the BIAS ADJUST control (on top of the chassis) fully counterclockwise.
- ( ) Connect the socket on the power supply cable to the Transceiver power plug.
- ( ) Connect the power supply to the proper power source.
- ( ) Connect an 8  $\Omega$  speaker to the 8  $\Omega$  socket at the rear of the Transceiver. CAUTION: Never operate the Transceiver unless a speaker or headphones are connected. For safety reasons, it is not recommended that headphones be used during the testing of the Transceiver.

If abnormal operation is encountered at any time during the following tests, turn the Transceiver off immediately, and refer to the In Case Of Difficulty section of the Manual on Page 112.

- ( ) Turn the FUNCTION switch to PTT. The panel lamps should now light with equal brilliance.
- ( ) Turn the METER switch to HV. The panel meter should indicate +800 to +900 volts.
- ( ) Visually check all parts for any signs of overheating, and check to see that each tube filament glows.
- ( ) Turn the METER switch to PLATE. The panel meter should indicate zero.
- ( ) Turn the AF GAIN control in a clockwise direction until noise is heard from the speaker. NOTE: If no noise is heard, check to be sure the transmitter is not keyed by a depressed switch on a PTT microphone, or a closed key.

Check the voltages listed in the next two steps with a voltmeter. Refer to Figure 1-2 (fold-out from Page 99) for the location of test points.

- ( ) +300 volts DC from point 5 on the bandpass circuit board to chassis ground.
- ( ) -111 volts DC (bias) from point 4 on the audio circuit board to chassis ground.

## ALIGNMENT

The coils and transformers in your Transceiver have been preset at the factory. Only slight readjustments should be necessary during the following alignment procedure.

The following equipment is necessary for alignment of the Transceiver.

1. An 11 megohm input VTVM, such as the Heath Model IM-11, (a 20 K $\Omega$ /V VOM may also be used).
2. A 50  $\Omega$  nonreactive dummy load that is capable of 100 watts dissipation, such as the Heathkit Model HN-31. Do not use light bulbs as a dummy load, as their resistance varies radically with voltage.
3. A receiver capable of receiving WWV, such as the Heath Model GR-54, at 2.5, 5, 10, or 15 MHz. If this type of receiver is not available, a receiver tunable to a standard broadcast station that is operating at an even multiple of 100 kHz (such as 600 kHz, 1000 kHz, etc.) can be used.

For the alignment of the transmitter section it is recommended that you use an oscilloscope, such as the Heathkit Model SB-610 Monitor Scope to observe the output RF envelope.

**WARNING:** Do not place the Transceiver in the transmit mode of operation until directed to do so or the Transceiver may be seriously damaged.

- ( ) Set the ANTENNA switch (located on rear of chassis) to the COM position.
- ( ) Connect a 50  $\Omega$  dummy load, capable of 100 watts dissipation, to the RF OUT jack on the rear of the chassis. CAUTION: Do not use light bulbs as a dummy load.
- ( ) Be sure an 8  $\Omega$  speaker is connected to the 8  $\Omega$  jack on the rear of the chassis.
- ( ) Preset the CAL XTAL trimmer so its notch is towards the 100 kHz crystal as shown in Figure 1-1 (fold-out from Page 82).

- ( ) Preset the front panel controls as follows:

DRIVER PRESELECTOR - 12 o'clock position (3.7, 7.2, 14.2).

MIC/CW LEVEL - fully counterclockwise.

MODE - LSB

BAND - 3.5

Main tuning dial (LMO) - 3.7 MHz (upper dial pointer at 2, and the circular dial at 0).

FUNCTION - PTT.

FREQ CONTROL - LOCKED NORMAL.

RF GAIN - fully clockwise.

FILTER - SSB.

METER - ALC.

AF GAIN - 9 o'clock position.

### S-METER ADJUSTMENT

- ( ) After a few minutes warmup, adjust the METER ZERO control (on the IF circuit board directly behind the FREQ CONTROL switch) for a zero reading on the panel meter.

### RECEIVER ALIGNMENT

- ( ) Set the VTVM switches so the meter will indicate a negative (-) DC voltage.
- ( ) Connect the common lead of the VTVM to the chassis and the other lead to the circuit board foil at TP on the screened side of the bandpass circuit board near tube V19.

The heterodyne oscillator output will be checked at each position of the BAND switch in the following steps. If necessary, the heterodyne oscillator coils will be adjusted to obtain a preliminary output voltage reading. Final adjustment will be made later.

- ( ) With the BAND switch at 3.5, the VTVM should indicate about -0.5 to -2 volts DC. If necessary, adjust coil 3.5 (near tube V11 on the top side of the RF-driver circuit board) for the proper VTVM reading. NOTE: When adjusting this coil in one direction, the oscillator output voltage will change rapidly; when adjusting the coil in the opposite direction from the peak, the output voltage will change slowly. Adjust the coil in the direction that gives the slower change in output voltage.
  - ( ) Similarly, check the heterodyne oscillator output voltage at all positions of the BAND switch. If necessary, adjust the correct heterodyne oscillator coil for any BAND switch position that does not give an indication of about -0.5 to -2 volts DC on the VTVM. The heterodyne oscillator coils for bands 3.5, 14, and 28.5 are marked, and adjusted at the top side of the RF-driver circuit board; the coils for the other bands are marked on the shield cover, and are adjusted from the bottom of the chassis.
  - ( ) Set the FUNCTION switch to CAL and the BAND switch to 3.5, then turn the Main Tuning dial back and forth around 3.7 MHz to get the loudest signal. Check for the calibrate signal by turning the FUNCTION switch to VOX and back to CAL; the signal should stop and then start again and should peak with the DRIVER PRESELECTOR.
  - ( ) Reset the DRIVER PRESELECTOR to the 12 o'clock position.
  - ( ) Disconnect the VTVM leads from the Transceiver.
- The S-Meter will be used as an output indicator during the remaining alignment of the Transceiver, and the 100 kHz calibrator will be used as a signal source.
- ( ) Adjust transformer T201 for maximum volume.
  - ( ) Adjust the top and bottom slugs of transformer T102 for a maximum volume or S-Meter indication.
  - ( ) Adjust the slug of transformer T103 for a maximum S-Meter indication.
  - ( ) Repeat the adjustments of transformers T201, T102, and T103 for a maximum S-Meter indication.

The driver grid and driver plate coils will be adjusted in the following steps. The coil locations are marked on the shield cover at the bottom of the chassis. These coils must be adjusted in the proper sequence as follows:

- ( ) Adjust driver grid coil 3.5 and driver plate coil 3.5 for a maximum S-Meter indication. The S-Meter will move slowly during the adjustment of these two coils.

- ( ) Change the setting of the front panel controls as follows:

DRIVER PRESELECTOR - 29.2 position.  
See the inset drawing on Figure 1-2 (fold-out from Page 99).

BAND - 29.0

Main Tuning dial (LMO) - 29.2 MHz

- ( ) Turn the Main tuning dial back and forth around 29.2 MHz to get the loudest signal. Check for the calibrate signal by turning the DRIVER PRESELECTOR to see if there is any variation in volume. Return the DRIVER PRESELECTOR to the 29.2 position.

- ( ) Adjust driver grid coil 29 and driver plate coil 29 for a maximum S-Meter indication.

- ( ) Change the setting of the front panel controls as follows:

DRIVER PRESELECTOR - 21.2 position.  
See the inset drawing on Figure 1-2.

BAND - 21.0

Main tuning dial - 21.2 MHz.

- ( ) Turn the Main tuning dial back and forth around 21.2 MHz for the loudest signal. Check for the calibrate signal by turning the FUNCTION switch to VOX and back to CAL again.

- ( ) Adjust driver grid coil 21 and driver plate coil 21 for a maximum S-Meter indication.

- ( ) Turn the BAND switch to 14.0, the Main tuning dial to 14.2 MHz, and the DRIVER PRESELECTOR to the 14.2 position.

- ( ) Tune the Main tuning dial for the loudest signal and check for the calibrate signal.
- ( ) Adjust driver grid coil 14 and driver plate coil 14 for a maximum S-Meter indication.
- ( ) Set the BAND switch at 7.0, the Main tuning dial at 7.2 MHz, and the DRIVER-PRE-SELECTOR to the 7.2 position.
- ( ) Tune the Main tuning dial for the loudest signal.
- ( ) Adjust driver grid coil 7 and driver plate coil 7 for a maximum S-Meter indication.
- ( ) Turn the FUNCTION switch to PTT

Proper receiver operation will be indicated by calibrator signals of S9 +20 db at 3700 kHz and decreasing to S6 at 29.2 MHz.

### TRANSMITTER ALIGNMENT

See the "Reading The Meter" section on Page 108 before making any more adjustments.

NOTE: The coil cover must be in place for transmitter operation.

- ( ) Connect a push-to-talk microphone to the MIC connector on the front panel.
- ( ) If an oscilloscope is available, connect the oscilloscope between the RF OUT jack and the dummy load. Be sure the dummy load is capable of 100 watts dissipation.
- ( ) Set the NEUTRALIZING CAPACITOR (on the RF cage) at the 1/2 meshed position. The slot in the shaft should be vertical.
- ( ) Set the front panel controls as follows:  
DRIVER PRESELECTOR - 12 o'clock position.

MIC/CW LEVEL - fully counterclockwise.

FINAL (round knob) - to 80.

FINAL (lever knob) - over the 50  $\Omega$  marking.

MODE - LSB.

BAND - 3.5

Main tuning dial - 3.7 MHz.

FUNCTION - PTT.

FILTER - SSB.

### FREQ CONTROL - LOCKED NORMAL

#### METER - PLATE.

- ( ) Press the PTT microphone button and turn the BIAS ADJUST control in the Transceiver for a plate current reading of 50 ma. If the meter reads more than 100 ma, do not press the microphone button more than a few seconds at one time, until the plate current has been properly adjusted.
- ( ) If an oscilloscope is not used, preset the RELATIVE POWER control to the center of its range and turn the METER switch to REL PWR.
- ( ) With the MODE switch set at the TUNE position, slowly turn the MIC/CW LEVEL control in a clockwise direction until there is an indication of RF output on the meter or oscilloscope.
- ( ) Turn the MIC/CW LEVEL control for a low level of RF output, then adjust the DRIVER PRESELECTOR control for maximum RF output.
- ( ) Adjust the FINAL tune (round knob) control for maximum RF output.
- ( ) Turn the MIC/CW LEVEL control counterclockwise to obtain approximately 1/4 maximum output.
- ( ) Adjust transformer T1 for maximum RF output. It should not be necessary to adjust this transformer more than one complete turn.
- ( ) Turn the MIC/CW LEVEL control and DRIVER PRESELECTOR control to obtain maximum RF output on the meter or oscilloscope. Then turn the METER switch to GRID (grid current); the meter should indicate full scale.
- ( ) Turn the METER switch to the PLATE position.
- ( ) Adjust the FINAL tune control for minimum plate current. Turn the METER switch to REL PWR or observe the output on an oscilloscope. Adjust the FINAL tune control for maximum meter indication and note the position of the FINAL tune control. (If necessary, readjust the RELATIVE POWER control so the meter does not indicate beyond full scale.) If maximum relative

power and minimum plate current do not occur at the same point of tuning, then turn the neutralizing capacitor a small amount. Check the position of the FINAL tune control at minimum plate current and also at the maximum relative power indication. The neutralizing capacitor should be adjusted a small amount at a time until minimum plate current and maximum relative power occur at the same point of tuning the FINAL tune control.

- ( ) Turn the MIC/CW LEVEL control fully counterclockwise.
- ( ) Turn the MODE switch to LSB, push the PTT switch on the microphone, then adjust the CARRIER NULL control for minimum RF output. NOTE: Readjust the RELATIVE POWER control for more sensitivity if the panel meter is used to indicate relative power.
- ( ) Adjust the CARRIER NULL capacitor for minimum RF output.
- ( ) If necessary, repeat the adjustments of the CARRIER NULL control, and the CARRIER NULL capacitor until the RF output or null reading is about the same on both the LSB and USB positions of the MODE switch. (The output should null down to a quarter of a volt or less, if an RF voltmeter is available.)

**CAUTION:** The 6.8 MHz trap coil is sealed, and should not be turned.

- ( ) Turn the MODE switch to TUNE. Tune for maximum output, and adjust the RELATIVE POWER control for a 6 to 8 meter reading.
- ( ) Leave the BAND switch at 3.5, and adjust for a maximum output. Then set the MIC/CW LEVEL control for a grid current reading of about 0.3 ma.
- ( ) Adjust heterodyne oscillator coil 3.5 for maximum grid current, with the tuning on the "slow" side of the peak.
- ( ) At each position of the BAND switch, adjust the heterodyne oscillator coil for maximum grid current. Adjust the coil that has the same number as the BAND switch position.

- ( ) Check the grid current at each position of the BAND switch. The maximum grid current reading should be near or over full scale on each band.
- ( ) Set the BAND switch at 21.0 and turn the Main tuning dial to read 21.2 MHz.
- ( ) Position the free end of the driver neutralizing wire into hole W in the RF-driver circuit board as shown in Figure 1-1 (fold-out from Page 82).
- ( ) Adjust the DRIVER PRESELECTOR control for maximum RF output; then turn the control back and forth to see if this produces a smooth peaking in RF output.
- ( ) If the turning of the DRIVER PRESELECTOR control causes ragged changes in the RF output, readjust the position of, or bend, the driver neutralizing wire to produce a smooth peaking in RF output.
- ( ) Check the final neutralizing again at 14.2 MHz as in the last step on Page 95.
- ( ) Rezero the S-Meter while receiving, with the BAND switch at 29.5. Then check to be sure the meter reads zero in each Band switch position. If the S-Meter does not read zero on any band, readjust the heterodyne oscillator coil for that band, as directed in previous steps.

### CRYSTAL CALIBRATOR ALIGNMENT

In the following steps, the 100 kHz crystal calibrator signal is adjusted by "zero beating" it against the accurate signal from WWV on another receiver, or against the signal from a standard broadcast station that is on a multiple of 100 kHz.

Zero beat will occur when a harmonic of the 100 kHz crystal calibrator signal corresponds to the frequency of the station tuned in on the external receiver. As zero beat is approached, a tone will be heard that decreases in frequency until it stops completely at the zero beat point; then the tone begins to increase again.

If the external receiver has an S-Meter, accurate alignment can be achieved by observing the S-Meter as zero beat is approached. When you tune close to zero beat, the S-Meter will start to pulsate. The closer you approach zero beat, the slower the pulsations will become. At zero beat the pulsations will stop.

**IMPORTANT:** For greatest accuracy, be sure to adjust the crystal calibrator as close to zero beat as possible. A 20 Hz error at the 100 kHz calibrator frequency, for example, would cause a 740 Hz error at 3.7 MHz (where the 37th harmonic of 100 kHz would be used for dial calibration purposes;  $100 \text{ kHz} \times 37 = 3.7 \text{ MHz}$ ;  $20 \text{ Hz} \times 37 = 740 \text{ Hz}$ ).

( ) Connect the free end of the antenna wire from the external receiver to the REC ANT jack at the rear of the Transceiver.

( ) Set the Transceiver controls as follows:

FUNCTION switch - CAL.

AF GAIN control - full counterclockwise.

ANTENNA switch (at rear of Transceiver) - REC.

MODE switch - CW, LSB, or USB.

( ) Tune the external receiver to WWV; or a standard broadcast station broadcasting at a frequency which is a multiple of 100 kHz.

( ) Carefully adjust the CAL XTAL trimmer capacitor (on the bandpass circuit board) for a "zero beat" in the external receiver. When WWV is tuned in, the period when no tone modulation is present allows the zero beat to be more easily heard.

( ) Switch the Transceiver FUNCTION switch between VOX and CAL to be sure the external receiver S-Meter stays steady, thus insuring a true zero beat.

( ) Remove the external receiver antenna wire from the REC ANT jack on the Transceiver.

**NOTE:** To make sure it is heard on each band, a high content of harmonic energy is needed in the 100 kHz calibrate signal. Because of this, some spurious signals may also appear when tuning across some segments of the bands. The desired 100 kHz calibrate signals are easily identified by their greater signal strength. Also, the proper harmonics may be peaked by the DRIVER PRESELECTOR.

#### LMO SHIFTER ADJUSTMENT

( ) Adjust the Main tuning dial to 3.7 MHz (BAND switch to 3.5, the upper dial at 2, and the circular dial to 0).

( ) Set the FUNCTION switch to CAL.

( ) Turn the MODE switch to USB.

( ) Carefully zero beat the calibrator signal (using the Main Tuning dial) and peak the DRIVER PRESELECTOR control.

( ) Set the MODE switch to LSB. Be careful not to touch the Main Tuning dial. Note that the calibrator signal may or may not be exactly at zero beat in the LSB position.

( ) Turn the frequency shifter adjustment on the LMO for an exact zero beat in the LSB mode. See Figure 1-1 (fold-out from Page 82).

( ) Recheck the zero beat in the USB mode to be certain of the adjustment. Repeat the procedure if necessary.

#### DIAL CALIBRATION

( ) Zero beat the Main Tuning dial at 3.7 MHz.

( ) Check for the calibrate signal and set the Zero Set dial. If the hairline is not close to the window center, proceed with the following steps.

( ) Remove the knob from the Main Tuning shaft without disturbing the zero beat setting.

( ) Place a screwdriver through the hole in the dial escutcheon (directly above the main tuning shaft) and into the LMO dial drive shaft.

( ) Hold the LMO dial drive shaft on zero beat and loosen the setscrew in the circular dial. Turn the circular dial until the 0 is directly behind the line on the zero set dial. Now re-tighten the setscrew in the circular dial. Wrap tape around the allen wrench so you do not short circuit the pilot lamp socket with the allen wrench.

( ) Make sure the circular dial turns freely and the nylon spiral follower is properly engaged in the spiral groove before proceeding.

( ) Replace the knob on the Main Tuning shaft.

This completes the alignment of your Transceiver.



## SPECIAL CRYSTAL CONSIDERATIONS

### CRYSTAL CONTROL FOR MARS OR NET OPERATION

With the **FREQ** control switch of the Transceiver in the **UNLOCKED AUX** position, the transmitter operates at a fixed frequency that is determined by crystal Y5 in the crystal oscillator circuit of tube V5B. The receiver is still tuned by the LMO.

By placing the **FREQ** control switch in the **LOCKED AUX** position, both the transmitter and receiver frequencies are determined by crystal Y5.

**IMPORTANT:** Because of the steep-sided characteristics of Bandpass filter T202, operation of the Transceiver using a crystal at Y5 will be limited to approximately 25 kilohertz outside of each band. Also, since the **DRIVER PRESELECTOR** tunes the same circuit for both transmit and receive, the frequency spread between the transmit and receive frequencies is limited to about 20 kHz at 3.5 MHz, 40 kHz at 7 MHz, etc.

Select the crystal frequency for Y5 for the sideband to be used, or for CW operation. The examples below are for one of the **MARS** channels located at 7.305 MHz.

For USB and compatible USB-CW operation:

$$f_{x(USB)} = f_h - f_m - 3.3964$$

For LSB operation:

$$f_{x(LSB)} = f_h - f_m - 3.3936$$

For CW Net operation:

$$f_{x(CW)} = f_h - f_n - 3.3954$$

Definition of terms:

$f_x$  = Crystal frequency in MHz, for crystal Y5.

$f_h$  = heterodyne crystal frequency, different for each band:

<u>BAND</u>	<u><math>f_h</math> *</u>
3.5	12.3950
7.0	15.8950
14.0	22.8950
21.0	29.8950
28.0	36.8950
28.5	37.3950
29.0	37.8950
29.5	38.3950

$f_m$  = carrier frequency of desired SSB operation, further specified by LSB or USB designations. This is the operating frequency for SSB.

\*NOTE: Because of the manufacturing tolerances of the heterodyne crystals, these frequencies may be in error by as much as 1500 Hz. For critical applications it will be advisable to measure the heterodyne crystal frequencies exactly to obtain correct values of  $f_h$  for the above formulae.

To measure the heterodyne oscillator frequency, connect a frequency counter or a frequency meter through a small capacitor to pin 7 of V11. Leave the transceiver in the Receive mode with the **FREQ CONTROL** switch in the **LOCKED AUX** position, **RF GAIN** fully counterclockwise, in **PTT** and at **LSB**.

$f_n$  = Exact transmitter frequency for CW Nets. Use this where CW only is used on a specific frequency. This operation is not compatible with USB operation, as the receiving station would have to retune his receiver 1 kHz lower to receive SSB, and this would be impossible if he were crystal controlled.

Compatible USB-CW operation is used in some MARS Nets. In this service, a channel is specified which is wide enough for only one sideband. The carrier frequency is specified at the lower edge of the channel, and CW transmission is 1 kHz higher than the carrier frequency. This 1 kHz offset then produces a 1 kHz beat note in the receivers set to USB or CW without any tuning. Either USB or CW can then be transmitted or received.

When using auxiliary crystal control, switching modes will cause the transmitting frequency to change, except for compatible USB-CW operation. Therefore, care must be taken to avoid out-of-band operation by inadvertently switching to the wrong mode.

Example: Mars SSB on USB at 7,305 MHz.

$$f_{h(7.0)} = 15.8950$$

$$f_{m(USB)} = \frac{-7.3050}{8.5900}$$

$$8.5900$$

$$\underline{-3.3964}$$

$$f_{x(USB)} = 5.1936 \text{ MHz}$$

Caution: Always be sure to use the correct heterodyne crystal frequency.

When purchasing crystals for Y5, specify the frequency and the following characteristics:

Operation Mode.....	Fundamental.
Tolerance.....	.01 %.
Holder.....	HC-6/U.
Pin Diameter.....	.050".
Pin Spacing.....	.486.
Load Capacity ( $C_L$ )..	32 pf.
Internal Capacity ( $C_O$ ).	7 pf maximum.
Series Resistance ( $R_S$ ).	25 $\Omega$ maximum.
Drive Level.....	10 milliwatts.

The trimmer capacitor next to Y5 (AUX TRIM) can be adjusted for an exact MARS or Net frequency.

## HETERODYNE OSCILLATOR

The heterodyne oscillator crystals that are supplied with the Transceiver provide coverage from 3.5 to 4.0 MHz, 7.0 to 7.3 MHz, 14.0 to 14.5 MHz, 21.0 to 21.5 MHz, and 28.0 to 30.0 MHz. Since the driver grid and driver plate coils must be sequence-tuned, because of their series-parallel arrangement, other heterodyne crystals for out-of-band operation could introduce a wide variety of possible tuning conditions. Therefore, the use of crystals of frequencies other than those supplied is not recommended.

## CABINET INSTALLATION

**NOTE:** If the Transceiver is to be mounted with the Heathkit Mobile Mount, Model SBA-100-1, be sure to install the plastic snap-in nuts in the side-front corners of the chassis and install the threaded bushing in the rear apron of the chassis. These parts are supplied with the Mobile Mount.

Refer to Figure 1-6 for the following steps.

- ( ) Position the cabinet right-side up on the work area.
- ( ) Remove the tape from around the front panel edges.
- ( ) Slide the chassis into the cabinet from the front.
- ( ) Carefully turn the cabinet and chassis over.
- ( ) Install a rubber foot at each rear corner with 6-32 x 5/8" screws and #6 flat washers. The screws fit through the cabinet holes into the tapped holes in the chassis.
- ( ) Install a rubber foot and a foot spacer at each front corner of the cabinet with a 6-32 x 1-1/2" screw and a #6 flat washer.
- ( ) Remove the protective backing from the high voltage label. Then press the label firmly in place inside the cabinet cover, as shown. It may be necessary to trim the label to size.
- ( ) Start 8-32 x 1/4" oval head screws into the front-side holes of the cabinet.
- ( ) Close the cover and tighten the screws.

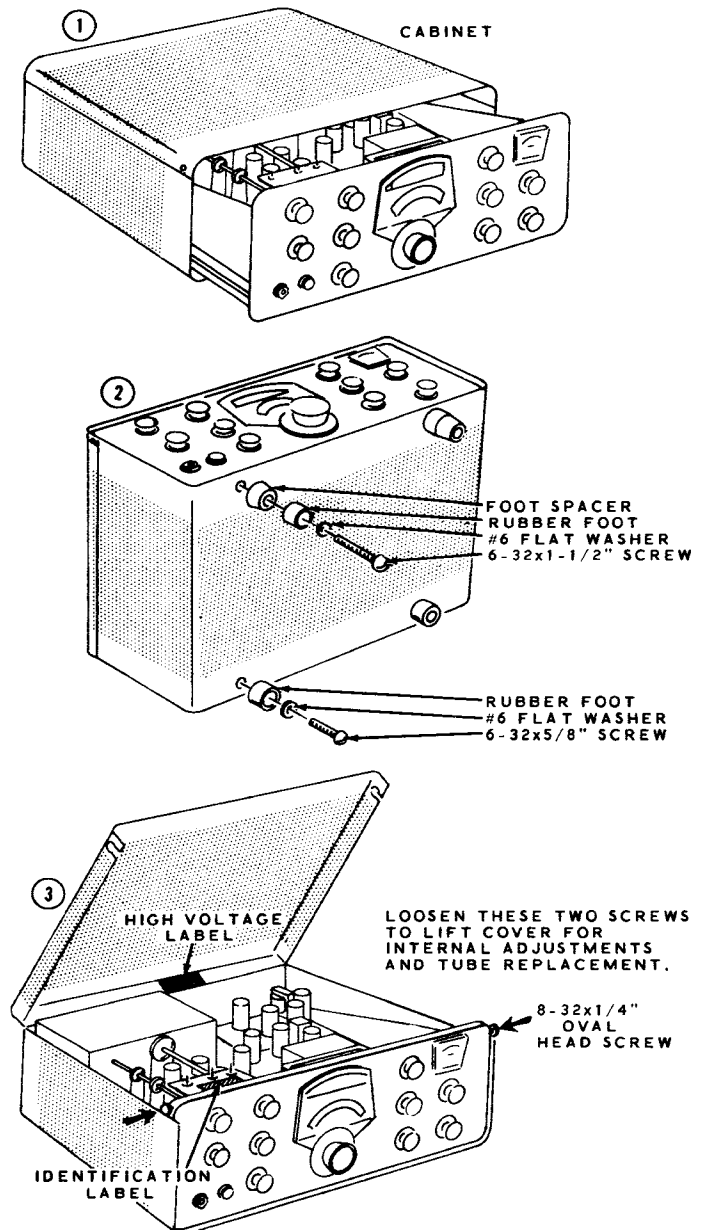

Figure 1-6

### MICROPHONE CONNECTION

Refer to Figure 1-7 for the following steps.

**NOTE:** A high-impedance microphone equipped with a push-to-talk switch should be used with the Transceiver so either the PTT or VOX methods may be used to turn on the Transmitter. A two-pin microphone connector (Amphenol 80MC2M) is furnished for this purpose. It should be connected to the microphone cable as directed in the following steps.

- ( ) Determine the desired length of your microphone cable, and cut off any excess. Unbraid the shield for a distance of 7/8".
- ( ) Remove 1/2" of insulation from the ends of the two inner leads. Then melt a small amount of solder on the exposed lead ends. Now proceed to the steps on Figure 1-7.

### IDENTIFICATION LABEL

**NOTE:** The blue and white identification label shows the Model Number and Production Series Number of your kit. Refer to these numbers in any communications with the Heath Company; this assures you that you will receive the most complete and up-to-date information in return.

- ( ) Install the identification label in the following manner:

1. Select a location for the label where it can easily be seen when needed, but will not show when the unit is in operation. This location might be on the control bracket. See Figure 1-6.

2. Carefully peel away the backing paper. Then press the label into position.

- ( ) Fill out the registration card and mail it to the Heath Company.

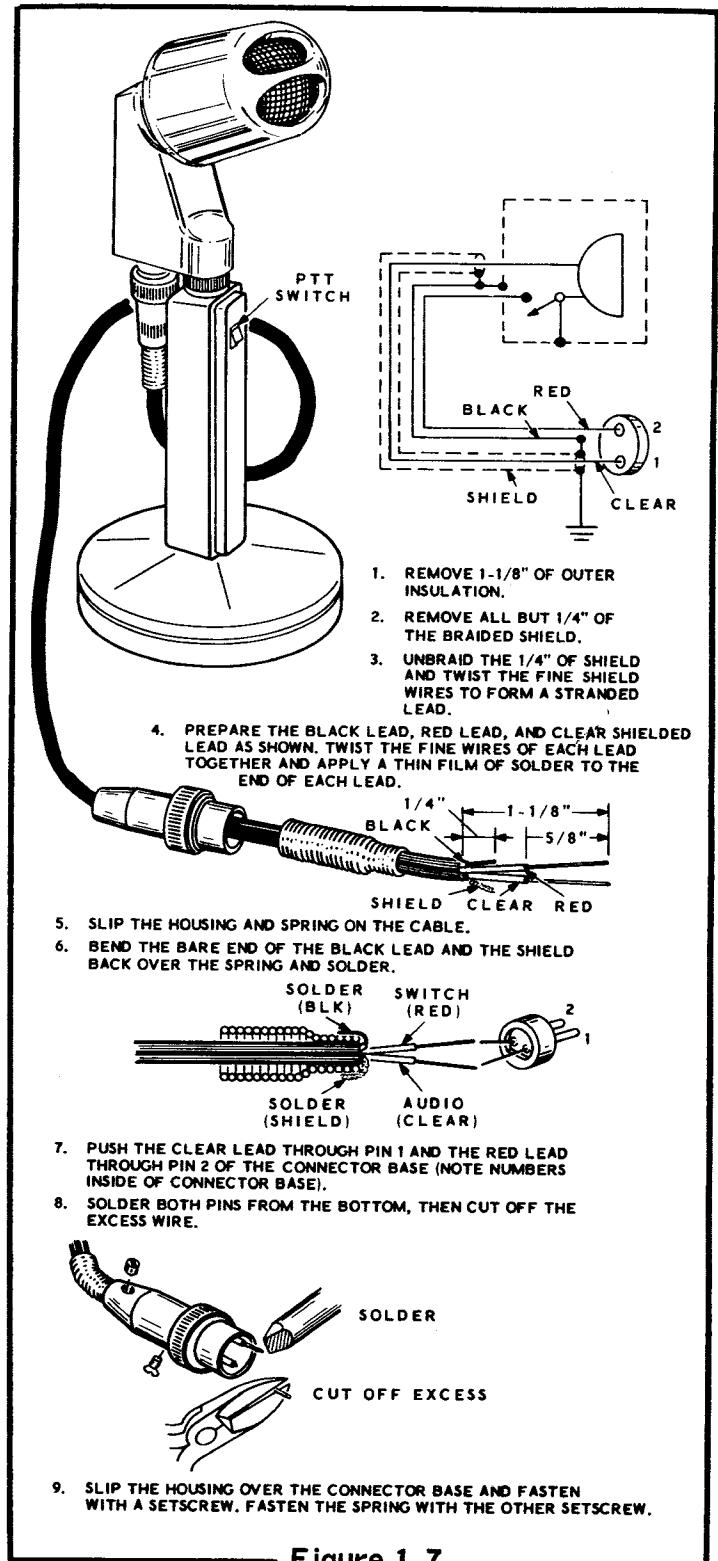

Figure 1-7

# INSTALLATION

Because of the heat generated by the tubes of the Transceiver, it should be placed where adequate air circulation is present. Do not place other equipment, papers, or other objects under or on top of the Transceiver that would cut off air circulation through the unit.

## FIXED STATION INSTALLATION

Figure 1-8 shows a Typical fixed station hook-up. Various accessories are shown that may be used with the Transceiver. These same accessories may also be used with a linear amplifier; however, the linear amplifier is shown separately in Figure 1-10 for clarity.

When using the Transceiver as a complete station unit, the ANTENNA switch should be in the COMMon position as shown in Figure 1-8.

Cables can be prepared following the instructions in Figure 1-9. Make the cables to the lengths required for your installation.

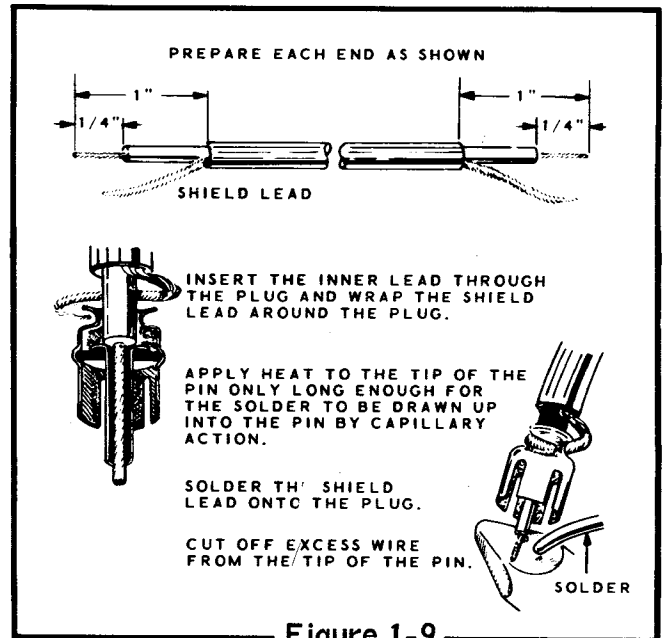

Figure 1-9

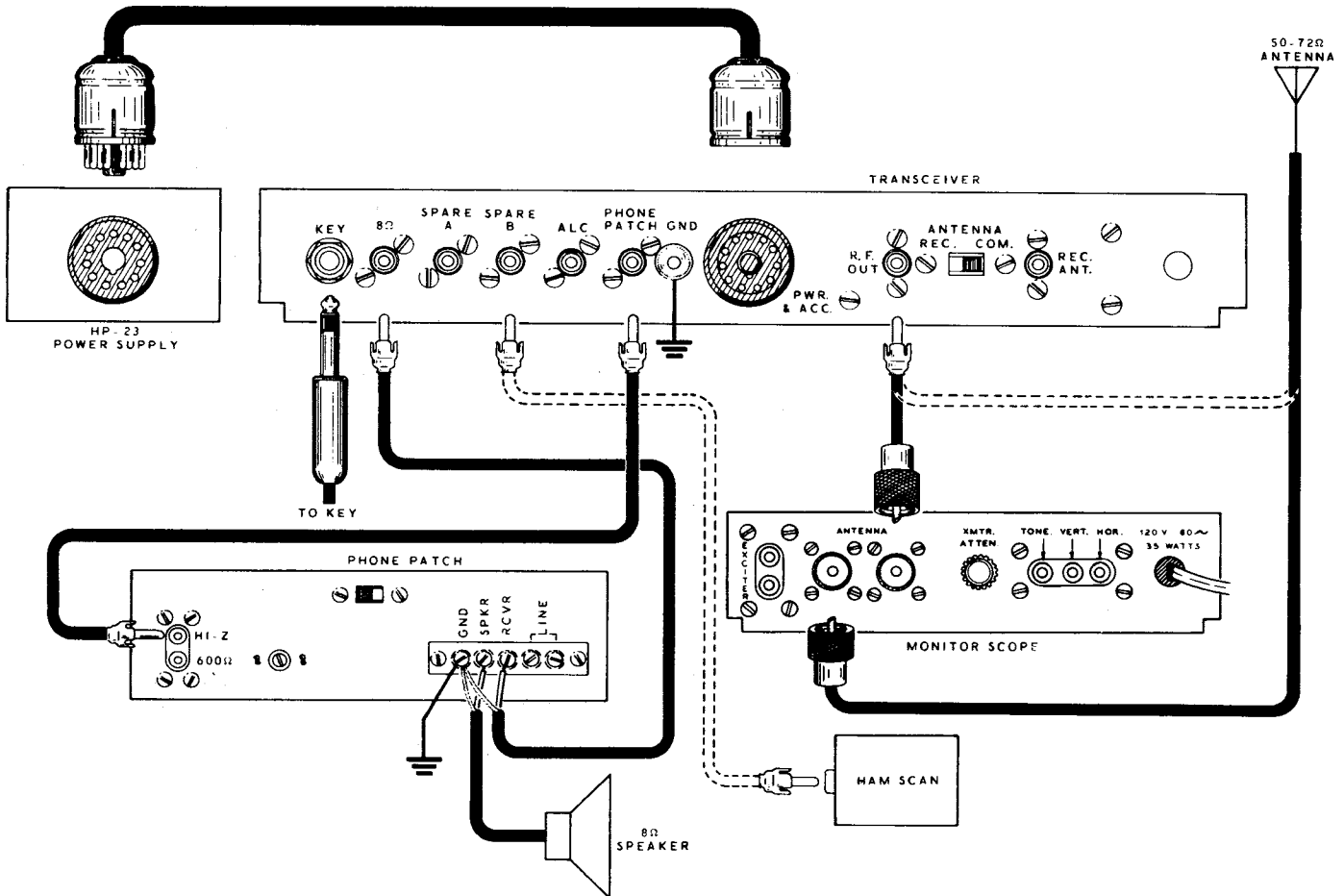

Figure 1-8

**Linear Amplifier Considerations**

**SB-200 AND HA-14**

Figure 1-10 shows a typical installation using an SB-200 amplifier. This linear amplifier provides ALC voltage and has internal antenna switching.

The Model HA-14 Linear Amplifier is similar in use to the Model SB-200. Neither Amplifier requires a swamping pad.

**OTHER LINEAR AMPLIFIERS**

Information regarding antenna switching, cutoff bias, and ALC should be obtained from the Linear Amplifier Instruction Manual.

A spare set of SPDT relay contacts are available at the PWR and ACC (power and accessory) plug of the Transceiver (pins 5, 8, and 11). These contacts can be used to switch an external antenna relay. Power for the external antenna relay will have to be obtained externally. Under these conditions the ANTENNA switch should be in the RECEIVE position with the coaxial cables connecting the RF OUT to the linear amplifier; the linear output, the antenna, and the REC ANT to the relay.

If the linear amplifier being used has internal antenna switching capabilities, the ANTENNA switch on the Transceiver can be at the COMMON position. Under these conditions, an external antenna relay is not necessary, and there will be no connection to the RECEIVER ANTenna jack on the Transceiver. The spare relay contacts in the Transceiver can now be used to switch either the cutoff bias or the internal antenna relay of the linear amplifier.

If the output power of the Transceiver is too high for the drive requirements of the linear amplifier, a swamping T-pad must be used between the two units. Such a pad is shown below. This pad will provide 10 dbattenuation with a terminal impedance of 50 ohms. This will allow adequate driving power for a linear amplifier that requires 10 watts input.

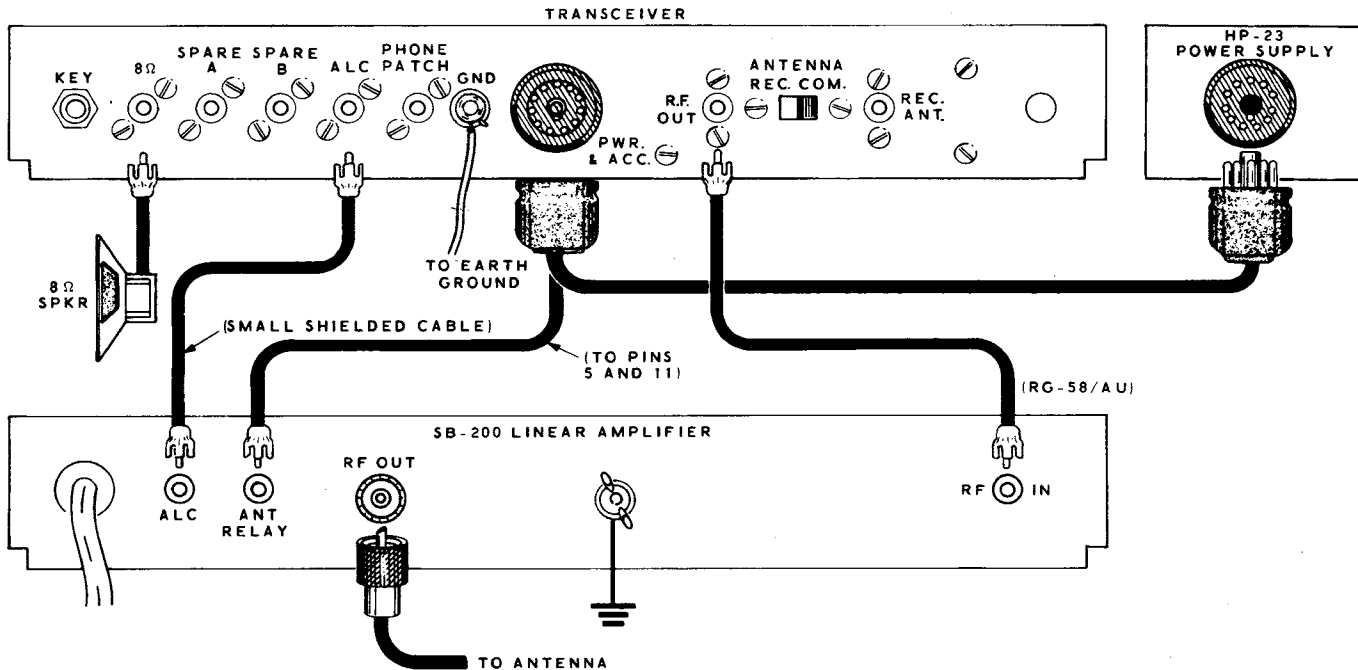
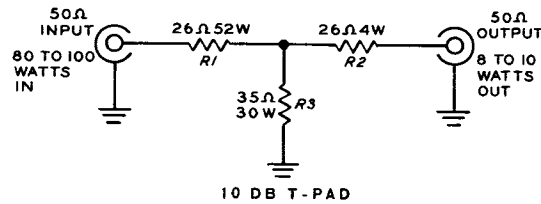

Figure 1-10

## T-Pad

Resistors R1, R2, and R3 can be made from combinations of common 2 watt carbon resistors wired into a metal box with phono-type jacks or connectors. NOTE: Do not use wire-wound resistors; the resistors in the T-pad must be a non-inductive type.

Combinations of 2 watt carbon resistors for a pad suitable for SSB service at reduced power levels, are listed below. WARNING: Steady full level carrier excitation should be avoided except for very brief test periods, since the dissipation rating of the resistors will be exceeded.

R1 = thirteen  $330 \Omega$  2 watt carbon resistors in parallel.

R2 = two  $47 \Omega$  2 watt carbon resistors in parallel.

R3 = eight  $270 \Omega$  2 watt carbon resistors in parallel.

## MOBILE INSTALLATION

A Mobile Mount (Heathkit Model SBA-100-1) is available for use with the Transceiver, and is recommended for Mobile operation. With this mount, the Transceiver can be quickly and easily installed or removed so it can be used for mobile and fixed station operation.

Be sure the voltage regulator of the automobile is set to not exceed 14.5 volts.

### Mobile Antennas

Mount the antenna according to the manufacturer's instructions. Be sure to make a good ground connection between the shield of the coaxial cable and the car body at the antenna base.

Mobile antennas present loading situations which must be carefully handled for each band. Because whip antennas must be kept short for mobile use, they represent only a fraction of a wavelength on the lower frequency bands. Thus, their radiation resistance is extremely low and their reactance is capacitive. Therefore, loading coils must be used and the losses kept low to insure a minimum loss of radiated power in the form of heat in the loss resistances.

A good quality antenna will have low resistance losses, and with a high "Q" loading coil, its bandwidth on 75 meters could be less than the IF bandwidth of many receivers used for AM reception. A typical loading coil with a "Q" of 300 would have a bandwidth of 13 kHz to the half-power points at 3.9 MHz.

Because of this sharp tuning, deviation from the center frequency of the antenna will quickly introduce enough reactance to present an impossible loading situation to the transmitter. The antenna should be carefully adjusted for a low SWR before placing the transmitter in operation.

The following is a list of antenna considerations for each band of the Transceiver.

### 3.5-4 MHz

This band presents the greatest problem. The normal tuning range of a good antenna on this band is about 10 kHz on each side of the antennas resonant frequency.

Actual measured resistance at the base of an antenna at these frequencies is 15 to 20 ohms; this represents an SWR of nearly 3 to 1. In order to get proper matching to the 50 ohm line, a 1000 pf mica capacitor should be connected between the inner conductor and shield of the coaxial line at the base of the antenna. Some antennas may require a different value, somewhere between 300 and 1500 pf.

The antenna tuning must be checked after the capacitor is installed. This capacitor is part of an L network that is used to get a 50 ohm match. The inductive portion of this network is formed by a portion of the loading coil.

### 7-7.3 MHz

This band ordinarily does not need a correcting network, and has a useful bandwidth of about 50 kHz.

### 14 MHz

No network needed. Bandwidth is approximately 100 kHz.

### 21 MHz

No network needed. Bandwidth is about 150 kHz.

### 28 MHz

The antenna for this band is normally cut for 1/4 wavelength, with no loading coil required. The bandwidth is about 200 kHz.

## TYPICAL TUNING PROCEDURE

The following is a typical tuning procedure.

A whip antenna that is properly tuned on 75 meters will have a high peak of receiver activity for about 25 kHz around the antenna's resonant frequency. Turn on the receiver and tune through the band to discover where this high peak of receiver activity is at for the present setting of your antenna. Then adjust the length of the whip in 1/4 inch increments and retune the receiver until the peak of receiver activity is centered around the frequency at which you normally operate. The antenna can then be tuned as described in the following steps. The receiver peaking may not be noticeable on bands other than 75 meters.

- ( ) 1. Connect an SWR meter in series with the lead to your antenna.
- ( ) 2. Set the SWR meter to the "forward" position.
- ( ) 3. Turn the Meter switch on your Transceiver to PLATE. If the meter needle does not point to 50 ma when the PTT button is depressed, perform the Bias Setting steps in the first step in the right-hand column on Page 95.
- ( ) 4. Turn the MODE switch to TUNE.
- ( ) 5. Adjust the MIC GAIN control for a full-scale meter indication on the SWR bridge. Peak the Final TUNE and DRIVER PRESELECTOR controls.
- ( ) 6. Switch the SWR meter to the "reverse" position. Note the SWR reading.
- ( ) 7. Switch the SWR meter to the "forward" position. Then set the transmitter to higher and lower frequencies, and repeat steps 5 and 6 at each frequency, until you find the minimum SWR.
- ( ) 8. Set the transmitter to the desired operating frequency. Then adjust the length of the antenna as follows:
  - A. If the point of the lowest SWR is lower than the desired operating frequency, shorten the antenna as described below.
  - B. If the point of lowest SWR is higher than the desired operating frequency, lengthen the antenna as described below.
  - C. Change the antenna length in 1/4" increments and repeat steps 2, 5, and 6 at each new length until the minimum SWR is obtained. The SWR should be about 1.2 or less at the desired frequency. NOTE: It may be necessary to add a capacitor at the base of the antenna, as described previously, if you cannot get the SWR down to about 1.2.



## Noise Suppression

To obtain good noise suppression, you must suppress electrical interference at its source, so it does not reach the input of the receiver. Once it has been radiated, noise cannot be suppressed by bypassing, etc.

It is difficult to determine the source of various types of noise, particularly when several items are contributing to the noise. Follow the procedure outlined below to isolate and identify the various items that may be producing the major noise interference.

In most cases, one source of interference will mask others. Consequently, it will be necessary to suppress the strongest item first, and then continue with the other steps. Figure 1-11 shows a typical ignition system and the suggested placement of noise suppression components.

1. Position the vehicle in an area that is free from other man-made electrical interference such as power lines, manufacturing processes, and particularly other automobiles.
2. With the Transceiver on, run the automobile at medium speed. Then let up on the gas, and turn the ignition switch off and to the accessory position. Allow the vehicle to coast in gear. If all noise stops, the major source of interference is from the ignition system.
3. If the noise interference continues from step 2, but at a reduced level, both the ignition and generator systems are at fault.
4. If the noise has a "whine" characteristic and changes in pitch with varying engine speed and is still present with the ignition off, then the generator is the major source of interference.
5. A distinct but irregular clicking noise, or "hash" as it is sometimes called, that disappears with the engine idling, indicates the voltage regulator is at fault.
6. A steady popping noise that continues with the ignition off indicates wheel or tire static interference. This is more pronounced on smooth roads.
7. The same type of interference as in step 6, but more irregular when on bumpy roads, particularly at slow speeds, indicates body static.

Refer to the Troubleshooting Chart on Page 107 and Figure 1-11 (fold-out from Page 107), to help determine how to suppress most noise interference. Naturally, not all vehicles will require suppression to the extent shown in Figure 1-11, but some stubborn cases may require all the suppression components shown, plus shielding of the ignition system.

Bonding of various parts of the automobile, starting from the hood and continuing to the trunk, even including bonding of the transmission line every few feet from the antenna may be necessary.



## NOISE SUPPRESSION TROUBLESHOOTING CHART

TYPE OF NOISE	POSSIBLE CAUSE	RECOMMENDED REMEDY
Loud popping increasing to buzz with increased engine speed.	Ignition system.	<ol style="list-style-type: none"> <li>1. Replace plugs with resistor type. (Most recommended.)</li> <li>2. Loose crimped connections should be cleaned and soldered.</li> <li>3. Place resistors in distributor system.</li> </ol>
Whine - varies with engine speed.	Generator.	<ol style="list-style-type: none"> <li>1. 0.1 <math>\mu</math>fd coaxial type capacitor in series with the armature (A lead).</li> <li>2. Clean commutator.</li> <li>3. Replace brushes.</li> <li>4. Ground generator shaft.</li> <li>5. Parallel trap (#10 wire-coil and suitable capacitor) in series with armature lead, tuned to operating frequency.</li> </ol>
Distinct but irregular clicking noise.	Voltage regulator.	<ol style="list-style-type: none"> <li>1. 0.1 <math>\mu</math>fd coaxial type capacitor in series with the battery (B) and armature (A) leads.</li> <li>2. A series combination of a .002 <math>\mu</math>fd mica capacitor and a 4 <math>\Omega</math> carbon resistor to ground from the field (F) terminal. All components should be mounted as shown in diagram, close to voltage regulator.</li> </ol>
Same as above.	Energy transfer to primary system.	<ol style="list-style-type: none"> <li>1. Bypass at the following points: coaxial bypass in lead to coil from ignition switch (0.1 <math>\mu</math>fd). Battery lead to ammeter (.5 <math>\mu</math>fd); to gas gauge (0.5 <math>\mu</math>fd); to oil signal switch (0.5 <math>\mu</math>fd); head and tail light leads (.5 <math>\mu</math>fd); accessory wiring from engine compartment (.5 <math>\mu</math>fd).</li> </ol>
Loud popping noise that changes from one type road to another. Most pronounced on concrete.	Wheel static.	<ol style="list-style-type: none"> <li>1. Installation of front wheel static collectors (available from most automotive distributors). These should be checked every 5000 miles for excessive wear.</li> </ol>
Same as above.	Tire static.	<ol style="list-style-type: none"> <li>1. Injection of anti-static powder into tire through valve stem.</li> </ol>
Irregular popping noise when on bumpy roads, particularly at slow speeds.	Body static.	<ol style="list-style-type: none"> <li>1. Tighten all loose screws.</li> <li>2. Use heavy flexible braid and bond the engine to the frame and fire wall. Bond the control rods, speedometer cable, exhaust pipes, etc., to the frame.</li> </ol>

If an extensive amount of suppression is required, the engine should be retimed and tuned up at a reputable garage.

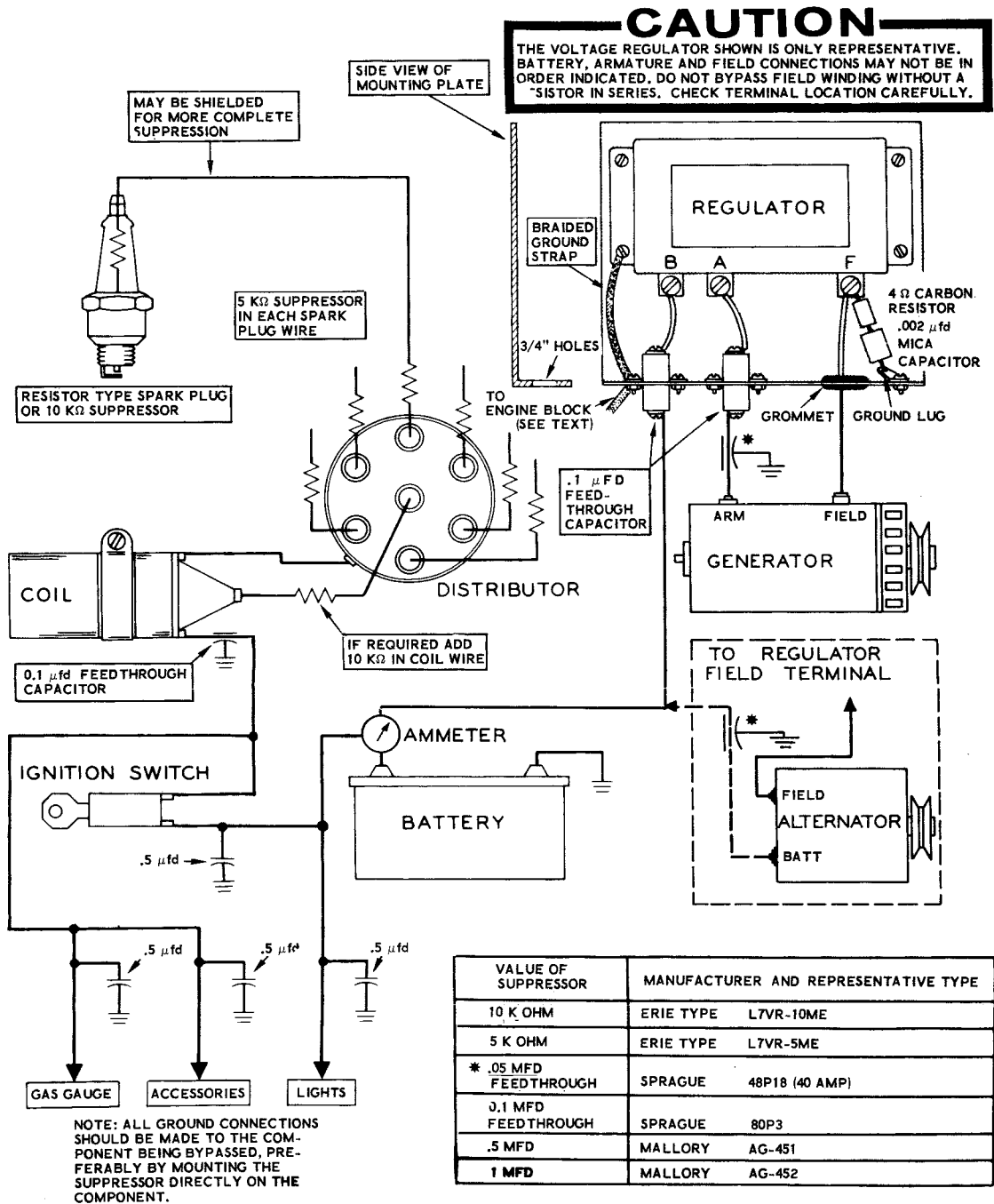

**FIGURE 1-11**

## OPERATION

**NOTE: YOU MUST HAVE AN AMATEUR RADIO OPERATOR AND A STATION LICENSE BEFORE PLACING THE TRANSMITTER SECTION OF THE TRANSCEIVER ON THE AIR. INFORMATION ABOUT LICENSING AND AMATEUR FREQUENCY ALLOCATIONS IS AVAILABLE FROM PUBLICATIONS OF THE FEDERAL COMMUNICATIONS COMMISSION OR THE AMERICAN RADIO RELAY LEAGUE.**

Operation of the Transceiver has been simplified as much as possible to permit rapid adjustment by the operator. Once the initial settings have been made, it should not be necessary to readjust most of the controls. Read the following information carefully. Good operating techniques will provide good clean signals and long trouble-free life of the Transceiver.

**CAUTION:** Be sure a 50 to 75  $\Omega$  nonreactive load is connected to the ANT RF OUT jack before operating the Transceiver. This load can be an antenna, a dummy load, or a properly adjusted linear amplifier. (See the Installation section of the Manual on Page 102).

### READING THE METER

Refer to Figure 1-12, and study the meter scale. Note how it reads for various positions of the Meter switch. Observe that the meter has two main scales and an ALC area.

TOP 20db POINT REPRESENTS MAXIMUM ALLOWABLE MODULATION DETERMINED BY MICROPHONE LEVEL CONTROL

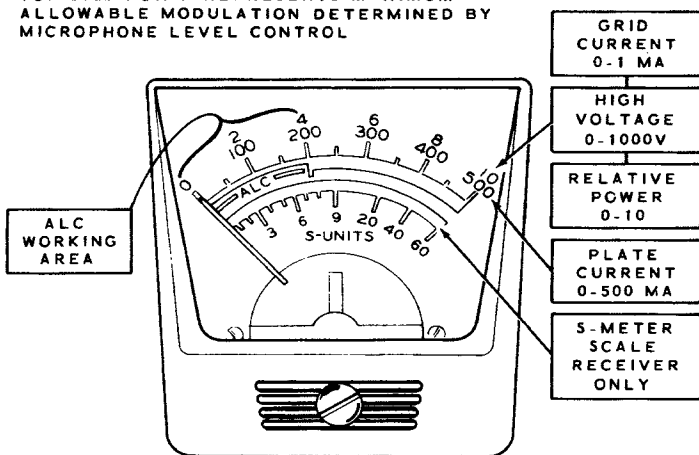

Figure 1-12

For receiver operation, the meter operates as an S-Meter and reads from 0 to 60, with the Meter switch in the ALC position.

For transmit operation, the scale numbered from 0 to 10 is read directly for relative power, 0 to 1 ma for grid current, and 0 to 1000 for high voltage indications. Read the 0 to 500 scale directly to read plate current in milliamperes.

### RECEIVER SECTION

Connect an 8  $\Omega$  speaker to the 8  $\Omega$  SPEAKER jack, or plug a set of headphones into the PHONES jack.

1. Set the MODE switch to either LSB or USB.
2. Set the FREQ CONTROL switch to LOCKED NORMAL.
3. Turn the RF GAIN control to its fully clockwise position.

If an extremely strong station overloads the receiver front end, or if there are many weaker signals near the desired signal, leave the AF GAIN control set for comfortable listening; then adjust the receiver level with the RF GAIN control. This will keep the front end from overloading and masking the weaker signals.

The S-Meter will move with adjustment of the RF GAIN control, but will still read correctly with the RF GAIN set at less than maximum, if the received signal level is high enough to register on the S-Meter. For example; if the RF GAIN control is set for a no-signal meter reading of S-5, and the meter registers S-9 with a signal, then the received signal is S-9.

4. Set the FUNCTION switch to PTT and allow the Transceiver to warm up.
5. Adjust the AF GAIN control clockwise until some receiver noise is heard.

**NOTE:** The AF GAIN control adjusts the overall receiver (speaker and headphones) volume. When headphones are used, set the HEADPHONE VOLUME control to the same relative level as the speaker. Then regardless of whether a speaker or headphones are used, only the AF GAIN control need be changed for different volume levels.

6. The Transceiver is now ready to receive. Turn the BAND switch to select the desired 500 kc band segment. The frequency of the tuned signal is determined by adding together the settings of the BAND switch, the upper dial, and the circular dial.
7. Peak the DRIVER PRESELECTOR for maximum signal.
8. Turn the FUNCTION switch to CAL. Rotate the Main Tuning dial (LMO) to the nearest 100 kHz point (0 on the circular dial).

Adjust the Main Tuning dial until the calibrate signal is at zero beat. (To be sure that the correct calibrate signal is being used, check the DRIVE PRESELECTOR tuning. If the signal strength varies, you are tuned to the correct calibrator signal.)

**WARNING:** Some portions of each band are for CW operation only. Do not operate the transmitter (with modulation) in the VOX or PTT modes if the receiver is tuned to these portions of the bands and the FREQ CONTROL switch is in the LOCKED NORMAL position, or the transmitted signal will be outside of the phone part of the band. (When the FREQ CONTROL switch is in the LOCKED NORMAL position, the transmitter and receiver operate on the same frequency.)

## TRANSMITTER SECTION

### Initial Tune Up

The first 10 steps of this procedure must be performed for all modes of operation.

1. Set the BAND switch and Main Tuning dial for the desired frequency.
2. Place the METER switch in the PLATE position.
3. Turn the MIC/CW LEVEL control fully counterclockwise.
4. Set the FREQ CONTROL switch to LOCKED NORMAL. If crystal control of the transmitter is desired, set the FREQ CONTROL switch to UNLOCKED AUX. (See the Special Crystal Considerations section on Page 98 of the Manual.)

5. With the RF load connected to the RF OUT jack, set the MODE switch to TUNE. The meter should read 50 ma.

**CAUTION:** For the following setups, do not leave the transmitter on at full output for extended periods of time or the final amplifier tubes and/or the power supply may be damaged.

6. Set the METER switch to REL PWR and adjust the FINAL loading control (lever knob) to 50.
7. Be sure the FINAL tuning (round knob) indicates the band segment of the band in use. **IMPORTANT:** Observe, while turning the MIC/CW LEVEL control clockwise, that the plate current and relative power readings reach a saturation point. Further increase in the setting of this control will show little or no increase in meter readings.
8. Turn the MIC/CW LEVEL control clockwise to obtain an up-scale indication on the meter. Then adjust the DRIVER PRESELECTOR, the FINAL tuning and FINAL loading controls for a maximum indication on the meter. Plate current should be approximately 250 ma with the MIC/CW LEVEL control set for maximum output.
9. Return the MIC/CW LEVEL control to its full counterclockwise position.
10. Place the MODE switch in the position for the desired mode of operation: USB, LSB, or CW.

**CAUTION:** The Transceiver should be retuned if the frequency is changed by any great amount. Be sure to readjust the FINAL tuning and loading controls. It may also be necessary to repeak the DRIVER PRESELECTOR control.

**NOTE:** The DRIVER PRESELECTOR peaks at slightly different position in transmit than in receive. For transceive operation it should be peaked on transmit.

This completes the Initial Tune Up. Before placing the Transceiver in operation, complete either the following CW or Single Sideband adjustments.

## CW Operation

For CW operation the FUNCTION switch can be set to either the PTT or VOX positions. Even though CW operation is possible in the CALIBRATE position, it is not recommended because of possible spurious outputs.

NOTE: For 400 Hz CW selectivity, the Heath SBA-301-2 CW Crystal Filter must be installed.

Be sure steps 1 through 10 have been satisfactorily completed before proceeding with the following adjustments.

11. Place the MODE switch in the CW position.

12. Plug a key into the CW KEY jack.

The VOX SENSitivity, ANTI-TRIP, and VOX DELAY controls are located on the control bracket under the cabinet cover.

13. While sending a series of "V's" adjust the VOX DELAY control so the relays stay energized between groups of characters. Clockwise rotation of this control will increase the holding time of the relays.

The final setting of the VOX DELAY control will be determined by the sending speed of the operator. The slower the sending speed, the higher the setting of this control. NOTE: Be sure the VOX DELAY control is adjusted so the relays do not open after each character is sent.

14. Hold the key down and adjust the CW TONE VOLUME control for a comfortable monitoring level.

NOTE: The frequency of the CW output signal is 1000 hertz higher than the dial reading. The received signal is actually in the USB position even though the MODE switch is set at CW. Consequently, cross-mode operation is possible between USB and CW without any resetting of the Main Tuning dial. For example, if two stations begin operation in the USB mode of operation and one operator changes to CW, the other station will hear a 1000 hertz note without retuning his receiver. Also, the station operating in the CW mode will receive the USB signal from the other station without

changing back to the USB position of the MODE switch. When operating in the LSB mode, the operator changes to USB or CW, contact will be lost until the other station changes to either USB or CW.

15. Adjust the MIC/CW LEVEL control for approximately 1/2 scale grid current for CW operation.

16. The FILTER switch may be used in either the SSB or CW position (with the 400 Hz filter installed) for CW operation, depending upon the receiver selectivity desired. Transmission will not be affected.

## Single Sideband Operation

Be sure steps 1 through 10 have been satisfactorily completed before proceeding with the following adjustments.

11. Set the MODE switch to either the USB or LSB position.

12. Set the FILTER switch to SSB.

13. Connect a microphone to the MIC connector.

14. Place the FUNCTION switch in the PTT position. (If your microphone does not have push-to-talk capabilities, make the VOX adjustments first, and then proceed with step 15.)

15. Set the METER switch to ALC.

16. Actuate the transmitter (PTT or VOX); and while speaking into the microphone, turn the MIC/CW LEVEL control clockwise until the peak deflections register at about S-6 on the meter. Do not allow the meter to deflect beyond the 20 db point.

NOTE: With the METER switch in the GRID position, there will be very little meter indication during voice operation.

## VOX ADJUSTMENTS

( ) Turn the MIC/CW LEVEL control fully counterclockwise. Leave this control in this position for the following adjustments.

( ) Set the FUNCTION switch to VOX.



NOTE: Close-talk into the microphone when using VOX operation to prevent background noise from tripping the Transceiver into transmit operation.

- ( ) While speaking into the microphone, turn the VOX SENSitivity control to just beyond a setting that will energize the relays. Be sure this control is not set so high that it will allow background noise to trip the relays.
- ( ) Tune the receiver to a fairly strong signal and adjust the AF GAIN control for a comfortable listening level.
- ( ) Place the microphone where it will normally be used, Advance the ANTI-TRIP gain control to just beyond a setting that will keep the speaker signal from tripping the relays (through the microphone and VOX circuits). Be sure this control is not set so high that it completely disables the relay closing action.
- ( ) While speaking into the microphone, turn the VOX DELAY control to a setting that will hold the relays energized during the slight pauses between words. This prevents the relays from tripping at the beginning and end of each word.

NOTE: There will be a slight interaction between the VOX SENSitivity, ANTI-TRIP, and VOX DELAY controls. Consequently, it may be necessary to readjust these controls slightly to achieve the desired results.

The Transceiver is now ready for transmit operation in the SSB mode. Speaking into the microphone (VOX) or using the microphone push-to-talk switch (PTT) will change the Transceiver from receive to transmit operation. Remember, as long as the FREQ CONTROL switch is in the LOCKED NORMAL position, the receiver and transmitter are locked on the same frequency.

## OPERATION WITH A LINEAR AMPLIFIER

Operation with a linear amplifier is similar to operation with an antenna at the output of the

Transceiver, except that the linear amplifier input may have a different impedance. This will make it necessary to adjust the FINAL Tuning and Loading controls for maximum output (input to the linear amplifier). Figure 1-10 on Page 103 shows the proper connections between a linear amplifier and the Transceiver.

## MOBILE OPERATION

If the Heathkit Model HP-13 Power Supply is to be used with the Transceiver in a mobile installation, and the BIAS control in the Transceiver has already been preset for fixed station operation, make the following adjustments.

- ( ) Turn the MIC/CW LEVEL control fully counterclockwise.
- ( ) Place the MODE switch in either the USB or LSB position.
- ( ) Set the FUNCTION switch to PTT.
- ( ) Place the METER switch in the PLATE position.

NOTE: The following adjustment should be made with the automobile engine running at about a 30 mph speed so the generator is charging.

Activate the transmitter with the push-to-talk button on the microphone, and adjust the bias control in the HP-13 Power Supply for a plate current reading of 50 ma. This will make it unnecessary to readjust the BIAS control of the Transceiver each time it is changed from mobile to fixed station use.

The VOX SENSitivity, VOX DELAY, and ANTI-TRIP gain circuits will operate in mobile use, but because of the different power supplies, it may be necessary to readjust these controls. For VOX operation, leave clearance in the mobile installation so the Transceiver cover can be opened to make these adjustments.

Transmitter loading may be somewhat more critical on mobile antennas because of their sharper frequency characteristics. Consequently, the mobile antenna must be tuned as closely as possible to the desired operating frequency with the lowest possible SWR (standing wave ratio).

## IN CASE OF DIFFICULTY

Refer to the Kit Builders Guide for Service and Warranty information.

A review of the Operation and Installation sections of the Manual may indicate any conditions overlooked.

**NOTE:** At no time should the LMO be opened or the Warranty will be voided. The LMO was aligned using the tube supplied. Changing this tube may cause some slight difference in calibration. Replace the tube with one of the same brand if replacement is necessary.

Refer to the Schematic Diagram (fold-out from Page 151) and to the Chassis Photos and X-Ray Views (Pages 146 to 151) for the location of parts.

Check the receiver and transmitter voltage readings against those shown in Figures 1-13A and 1-13B (fold-out from Page 112). Check the resistance readings against the readings shown in Figure 1-14 (fold-out from Page 113). All voltage readings were taken with an 11 megohm input digital voltmeter. Voltages may vary as much as 10%.

Refer to the Receiver Signal Voltage Chart (fold-out from Page 112) if a signal generator is used to troubleshoot the Transceiver.

**NOTE:** Breaks in the foil of the circuit boards can easily be detected by placing a bright light under the foil side of the board and looking through the board from the lettered side. A break will appear as a hair-line crack in the foil.

Wiring errors and poor soldering are the most common causes of difficulty. Therefore, the first step in troubleshooting is to recheck all wiring against the Pictorials and Schematic diagrams. Often, having a friend check the wiring will locate an error consistently overlooked.

Quite often, soldered connections that appear good will have an insulating coating of rosin between the wire, the terminal, and the solder. This results from insufficient heat being applied when soldering. Many troubles can be eliminated by reheating each connection to make sure that it is properly soldered as illustrated in the Proper Soldering Techniques section of

the Kit Builders Guide. The power cable should be removed from the power supply for such tests. As additional insurance against shock, a screwdriver blade should be used to short from the chassis to the red B+ wires.

If fuses blow instantly when power is applied to the unit, make resistance checks of the power supply, B+ circuits, and filament circuits. Check all tubes for possible shorts. Also refer back to the Initial Test section on Page 92. Check to be sure that all tubes are in their proper locations.

Be sure to read the Circuit Description so that "Cause-and-Effect" reasoning may be employed as the search for the trouble progresses. If some difficulty still persists after the steps outlined in the Troubleshooting Chart have been completed, try to localize the trouble to a particular stage in the circuit by using the voltage and resistance charts. Then refer to the Block Diagram and Schematic to visualize circuit relationships.

A VTVM will be needed to measure voltages. Most of the RF voltages can be measured with the aid of an RF probe.

A grid dip meter or wavemeter and a general coverage receiver are ideal instruments for checking operation of the RF circuits.

**NOTE:** If there is instability in the unit, check all circuit board mounting screws. These screws should be tight to the chassis and to the circuit board. Be sure lockwashers are against the foil side of the boards for good grounding.

The sealed relays used in this unit will be troublefree for years of normal use.

**DO NOT REMOVE ANY OF THE TUBES OR PILOT LAMPS WITH POWER APPLIED TO THE UNIT.** Because of the series-parallel filament circuit arrangement when using a 12 volt supply, removing the tube with power applied may destroy other tubes due to an increase in filament current through them.



- NOTES:**
1. POWER SUPPLY AND 8 Ω SPEAKER CONNECTED.
  2. ANTENNA NOT CONNECTED.
  3. BAND SWITCH IN 3.5 POSITION.
  4. MODE SWITCH IN LSB POSITION.
  5. FREQ. CONTROL SWITCH IN LOCKED NORMAL POSITION.
  6. FUNCTION SWITCH IN PTT POSITION.
  7. RF GAIN MAXIMUM CLOCKWISE.
  8. AF GAIN AT 9 O'CLOCK POSITION.
  9. FILAMENT VOLTAGES NOT SHOWN: -  
BROWN - 6.3 V AC/DC  
BROWN/WHITE - 12.6 V AC/DC
  10. BIAS AT 50 MA PLATE CURRENT.
- MEASURED WITH 11 MEGOHM INPUT VTVM.  
□ RF VOLTAGES - NO SIGNAL (USE RF PROBE WITH VTVM).

**RECEIVER SIGNAL VOLTAGE CHART**  
(Refer to Receiver DC Voltage Chart)

- NOTES:**
- CONTROL AND SWITCH SETTINGS AS IN DC VOLTAGE CHART EXCEPT AS FOLLOWS:
1. DIAL FREQUENCY - 3.895 MC.
  2. MODE SWITCH - LSB OR USB.
  3. AF GAIN - SET TO HEAR SIGNAL WITH APPROXIMATELY 1000 CPS TONE.
  4. METER SWITCH IN ALC POSITION.
- SIGNAL INPUT POINTS.

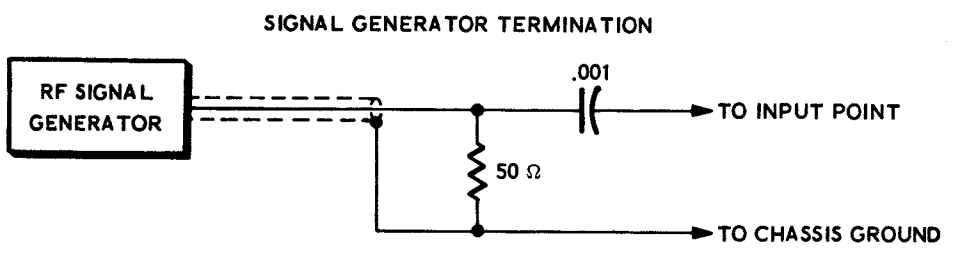

INPUT POINT	INPUT FREQUENCY	INPUT LEVEL	VTVM OR S-METER READING
1	3.395 MC	20 MV	(AF GAIN MAX. CLOCKWISE) 4 V RMS AT 8 Ω JACK
2	"	10 MV	S-4
3	"	10 MV	S-9 + 60 DB.
4	"	10 MV	S-9 + 60 DB.
5	"	10 MV	S-9 + 10 DB.
6	8.5 MC	10 MV	S-9 + 40 DB.
7	3.895 MC	10 MV	S-9 + 20 DB.
8	3.895 MC	10 MV	S-9 + 40 DB PEAK DRIVER PRESELECTOR
XTAL CAL ON	3.900 MC	10 MV	S-9 + 20 DB PEAK DRIVER PRESELECTOR
9*	3.900 MC	100 μV	S-9 APPROXIMATELY

\*GENERATOR CONNECTED DIRECTLY- NO TERMINATION.

**RECEIVER SIGNAL VOLTAGE CHART**

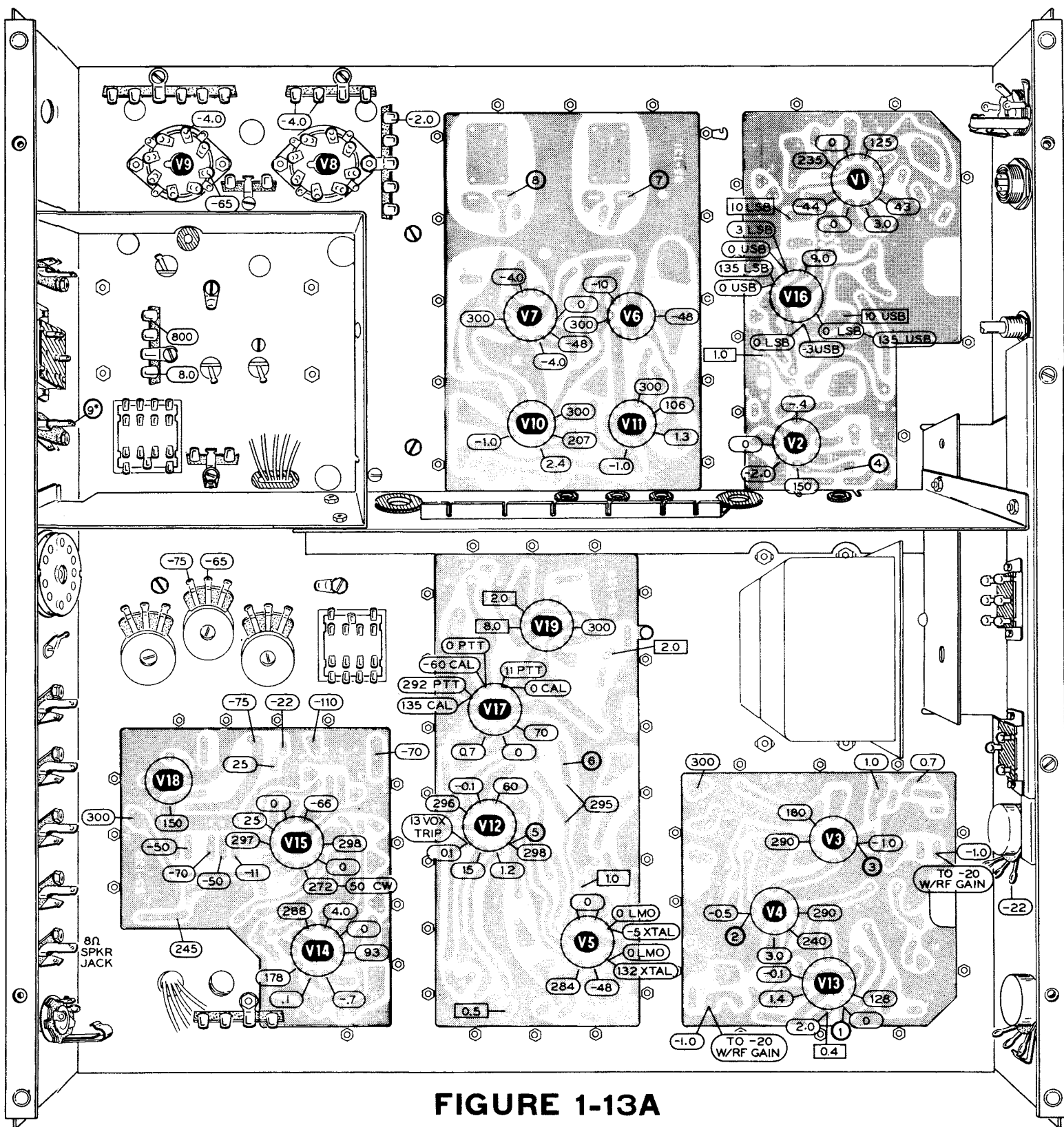

**FIGURE 1-13A**  
**RECEIVER DC VOLTAGE CHART**

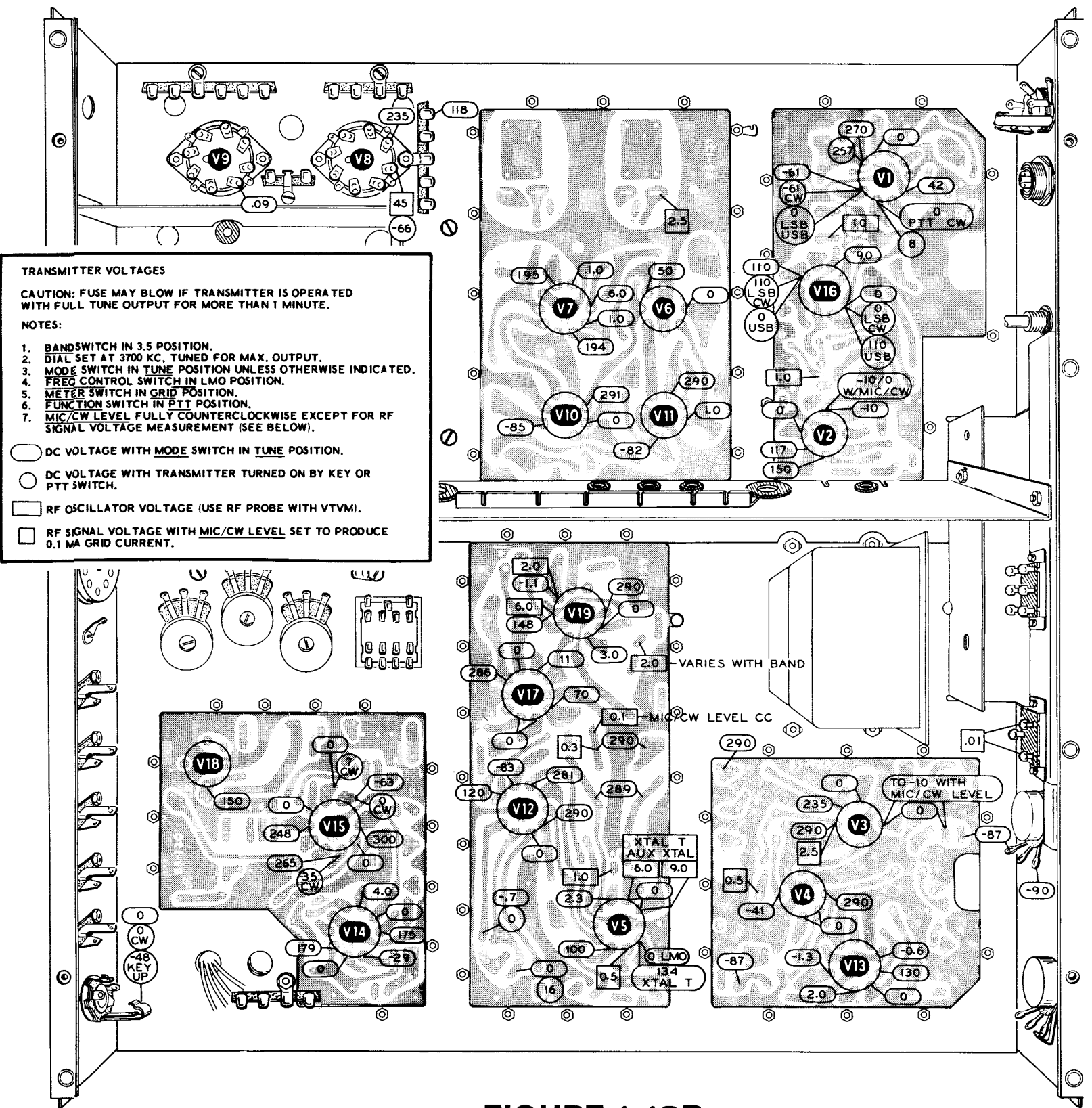

- TRANSMITTER VOLTAGES**
- CAUTION: FUSE MAY BLOW IF TRANSMITTER IS OPERATED WITH FULL TUNE OUTPUT FOR MORE THAN 1 MINUTE.**
- NOTES:**
1. BANDSWITCH IN 3.5 POSITION.
  2. DIAL SET AT 3700 KC. TUNED FOR MAX. OUTPUT.
  3. MODE SWITCH IN TUNE POSITION UNLESS OTHERWISE INDICATED.
  4. FREQ CONTROL SWITCH IN LMO POSITION.
  5. METER SWITCH IN GRID POSITION.
  6. FUNCTION SWITCH IN PTT POSITION.
  7. MIC/CW LEVEL FULLY COUNTERCLOCKWISE EXCEPT FOR RF SIGNAL VOLTAGE MEASUREMENT (SEE BELOW).
- DC VOLTAGE WITH MODE SWITCH IN TUNE POSITION.  
● DC VOLTAGE WITH TRANSMITTER TURNED ON BY KEY OR PTT SWITCH.  
□ RF OSCILLATOR VOLTAGE (USE RF PROBE WITH VTVM).  
□ RF SIGNAL VOLTAGE WITH MIC/CW LEVEL SET TO PRODUCE 0.1 MA GRID CURRENT.

**FIGURE 1-13B**  
**TRANSMITTER VOLTAGE CHART**

## TROUBLESHOOTING CHART

**NOTE:** References will often be made to previous Symptoms and Causes. Therefore, each Symptom is identified by a number, and each Possible Cause has an identifying letter. If you are directed, for example, to "check item 1C," refer to Symptom number 1, Possible Cause C.

SYMPTOMS	POSSIBLE CAUSE
1. No power, pilot lamps and tube filaments do not light, no B+ or bias voltage.	A. Power supply switch at off position. B. Power plug wired incorrectly. C. Power cable from power supply wired incorrectly. D. Defective AC snap switch on FUNCTION switch. E. In mobile installation, power supply leads reversed to battery. F. Fuses or circuit breakers open. G. Defective power supply. H. Faulty battery or battery cables.
2. Pilot lamps and tube filament light, but no bias or B+ voltage.	A. Check items 1B and 1C. B. Rectifiers defective in power supply. C. Transistors defective in DC power supply.
3. Bias and B+ voltage OK, but pilot lamps and tube filaments do not light.	A. Check items 1B and 1C. B. Large brown-white wires in wire harness open or wired incorrectly.
4. Low and high filament voltages on various tubes or pilot lamps.	A. Check item 3B. B. Brown leads used to balance filament voltages connected incorrectly, or not connected.
5. No regulated B+ (+150).	A. Relay RL2 wired incorrectly. B. Bad OA2 regulator tube, V18. C. Resistor R304 and/or R305 open or wired incorrectly.
6. Regulated B+ voltage too high.	A. Check items 5A and 5B. B. Resistor R304 and/or R305 wrong value.

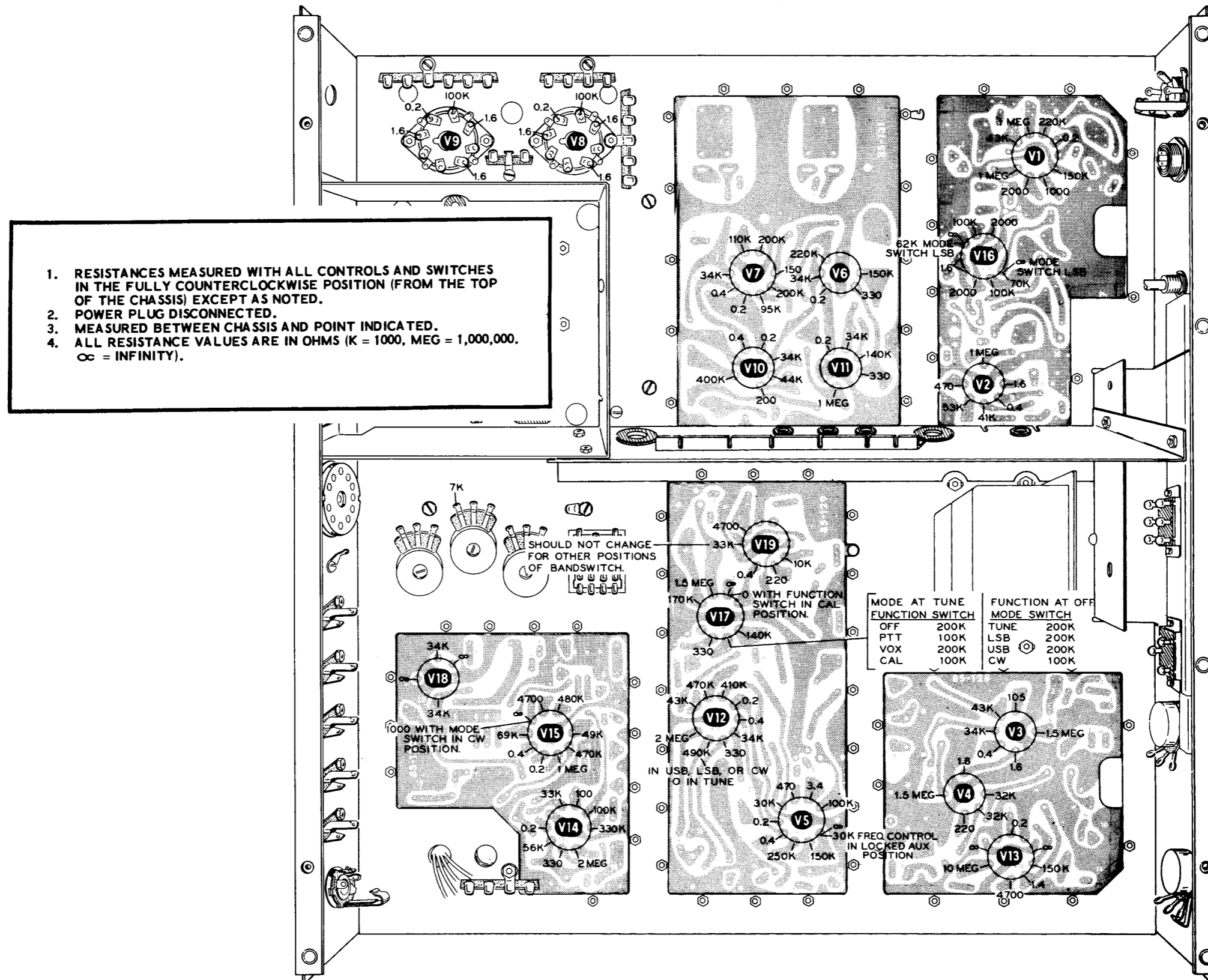

**FIGURE 1-14  
RESISTANCE CHART**

SYMPTOMS	POSSIBLE CAUSE
7. Regulated B+ voltage too low.	<ul style="list-style-type: none"> <li>A. Check items 5B and 6B.</li> <li>B. Shorted bypass capacitor in regulated B+ line.</li> </ul>
8. No screen voltage at tubes V10 and V11.	<ul style="list-style-type: none"> <li>A. Lugs 3, 7, or 11 of relay RL2 wired wrong.</li> </ul>
9. High-pitched audio oscillation unaffected by AF GAIN control.	<ul style="list-style-type: none"> <li>A. Red and blue audio output transformer leads reversed.</li> </ul>
10. No audio output from speaker or headphones.	<ul style="list-style-type: none"> <li>A. Check items 5A, 5B, and 5C.</li> <li>B. Defective transformer T301.</li> <li>C. PHONE VOLUME control wrong value, shorted, or wired backwards.</li> <li>D. Filter capacitor C304 shorted or installed backwards.</li> <li>E. Audio amplifier output tube V14 defective.</li> <li>F. Coaxial cables connected to AF GAIN control shorted.</li> <li>G. Leads reversed at lugs 3, 7, or 11 of relay RL2.</li> <li>H. Leads reversed at lugs 2, 6, or 10 of relay RL2.</li> </ul>
11. No audio output from speaker, but headphone output OK.	<ul style="list-style-type: none"> <li>A. Contacts 1 and 2 of PHONES jack open.</li> <li>B. Leads reversed to lugs 1 and 4 of PHONES jack.</li> <li>C. Speaker lead connected to wrong phono socket.</li> <li>D. Defective speaker.</li> <li>E. Output transformer green, black, or white leads connected wrong.</li> </ul>
12. Low or no audio output from headphones, but speaker output OK.	<ul style="list-style-type: none"> <li>A. PHONE VOLUME control set to its full counterclockwise position.</li> <li>B. PHONES jack wired incorrectly.</li> <li>C. Defective headphones.</li> </ul>
13. No signal or noise output, but very low hum output can be heard (speaker or phones).	<ul style="list-style-type: none"> <li>A. Check items 10A, 10F, and 10G.</li> <li>B. RFC101 open.</li> <li>C. Product detector tube V13 faulty.</li> <li>D. No carrier generator injection signal at product detector. (Check items 30A through 30F.)</li> <li>E. Red coaxial cable connected to AF GAIN control open or shorted.</li> <li>F. IF transformer T102 misaligned or defective.</li> <li>G. IF amplifier tubes V3 or V4 defective.</li> <li>H. Orange coaxial cable from V12 to crystal filter FL1 open or shorted.</li> <li>I. RF GAIN control wired backwards.</li> </ul>

SYMPTOMS	POSSIBLE CAUSE
14. No signal output, but noise output can be heard.	A. Transformer T201 misaligned or defective. B. No LMO injection signal at the cathode of V12A. (Check items 31A through 31E.) C. Coaxial cable connected between the bandpass and driver plate circuit boards, open or shorted. D. First IF amplifier tube V3 defective. E. Second receiver mixer tube V12A defective. F. No heterodyne oscillator injection signal at the cathode of V11. (Check items 33A through 33L.) G. First receiver mixer V11 or RF amplifier V10 defective. Also check item 4A. H. Coaxial cable connected between relay RL1 and the driver plate circuit board, open or shorted. I. Relay RL1 or ANTENNA switch wired incorrectly. J. Bandpass filter T202 defective. K. Crystal filter FL1 defective. L. FILTER switch in CW position.
15. Audio output with signal, but weak.	A. Low B+ supply voltage. B. Coils on driver plate, driver grid, and heterodyne oscillator circuit boards misaligned. C. Check items 4A, 7A, 13A through 13I and 14A through 14K. D. RF GAIN control is partially counterclockwise or wired incorrectly.
16. Receiver tends to be unstable, oscillates. (Receiver noise may be extremely high, or many "birdies" appear across tuning range.)	A. RF driver and IF circuit board mounting hardware not tight, or lockwashers left out between the chassis and circuit boards. B. Antenna transmission line open or shorted, or has high SWR. C. Supply voltage too high. Check items 6A and 6B. D. Transmitter cut-off bias too low.
17. Sideband reception reversed or highly distorted.	A. Carrier generator crystals Y1 and Y2 interchanged. B. CW carrier generator crystal Y3 interchanged with either Y1 or Y2. C. Leads reversed at lugs 13 and 17 on the FREQ CONTROL switch. D. FILTER switch in CW position.

SYMPTOMS	POSSIBLE CAUSE
<p>18. S-Meter inoperative, indicates backwards, is inoperative in some METER switch positions, does not zero, or zero shifts on some bands.</p>	<p>A. Leads connected to the meter are reversed.            B. Improper wiring of METER switch.            C. METER ZERO control improperly adjusted.            D. One of the following resistors is a wrong value: R103, R105, R106, R107, R110, or R115.            E. First or second IF amplifier tubes (V3 or V4) defective.            F. AVC line shorted to chassis.            G. Lugs 4, 8, or 12 of relay RL2 wired wrong.            H. V19, wrong type.            I. Heterodyne oscillator coils improperly set. Readjust (see steps on Page 94).</p>
<p>19. No screen voltage at driver tube V7.</p>	<p>A. Relay RL2 not energized. Check items 34A through 34C, and 35A through 35H.            B. Lugs 3, 7, and 11 of relay RL2 connected incorrectly.</p>
<p>20. Bias voltage does not shift to operating levels in transmit conditions.</p>	<p>A. Check item 19A.            B. Lugs 2, 6, and 10 of relay RL2 wired wrong.            C. BIAS ADJUST control set improperly.</p>
<p>21. No RF output from final, regardless of MODE switch position. (Driver output appears to be OK.)</p>	<p>A. No high voltage B+ at the plates of final amplifier tubes V8 and V9.            B. RF choke L901 open.            C. Lugs 8 and 12 of relay RL1 wired wrong.            D. Bias voltage too high at the grids of V8 and V9. (Check items 20A through 20C.)            E. FINAL controls not adjusted properly.            F. Final amplifier tubes V8 and/or V9 defective.            G. Rotor in switch on driver plate circuit board 180 degrees out of rotation.            H. Final knobs or shafts loose.</p>
<p>22. No RF output from driver regardless of MODE switch position. (Second transmitter mixer appears to be OK.)</p>	<p>A. No B+ voltage at the screen of V7. (Check items 19A and 19B.)            B. RFC801 open.            C. Bias voltage at grids of V8 and V9 too high. Check items 19A, 20B, and 20C.            D. Coils on the driver plate and grid circuit boards misaligned.            E. DRIVER PRESELECTOR control not adjusted properly.            F. Driver tube V7 defective.</p>

SYMPTOMS	POSSIBLE CAUSE
23. No RF output.	A. FILTER switch in CW position with no CW filter installed. B. FREQ CONTROL switch in wrong position. C. Antenna shorted. D. No B+ 800 volts.
24. No RF output from second transmitter mixer, regardless of the MODE switch setting. (First transmitter mixer appears to be OK.)	A. Check items 5A through 5C, 19A, 19B, 22D, and 22E. B. No heterodyne oscillator injection signal at cathode of V6. (Check items 33A through 33K.) C. Coaxial cable connected between the bandpass and driver plate circuit board open or shorted. D. Second transmitter mixer tube V6 defective. E. Check item 25B.
25. No output from first transmitter mixer regardless of the MODE switch position. (First IF amplifier appears to be OK.)	A. FREQ CONTROL switch in wrong position. B. Check items 19A, 19B, 20B, 20C, 22D, and 22E. C. No LMO output signal to cathode of V5 (pin 7). D. First transmitter mixer tube V5A defective. E. Blue coaxial harness cable connected between the IF and bandpass coupler circuit boards open or shorted. F. Capacitors C111 and C402 wrong value. G. Bandpass filter T202 defective. H. Check item 25B.
26. No RF output from first IF amplifier, regardless of the MODE switch position. (Isolation amplifier output appears to be OK.)	A. Check items 14A, 14C, 14D, 14K, 19A, and 19B. B. FILTER switch in CW position with no CW filter installed.
27. No RF output from isolation amplifier, regardless of the MODE switch position.	A. Check items 20B and 20C. B. Resistors R18, R19, R23, R24, R937, and/or R938 wrong value. C. Transformer T1 misaligned or faulty. D. Isolation amplifier tube V2 defective. E. Carrier oscillator not operating. (Check items 30B through 30E, and 31B through 31E.)

SYMPTOMS	POSSIBLE CAUSE
<p>28. No RF output with the MODE switch in USB or LSB, but output in Tune or CW positions OK.</p>	<ul style="list-style-type: none"> <li>A. Check items 10C, 10D, 10E, 20A, and 25A.</li> <li>B. No carrier injection signal to balanced modulator. (Check items 30B through 30E, and 31B through 31E.)</li> <li>C. Balanced modulator diodes CR1 through CR4, installed improperly, wrong type, or defective.</li> <li>D. Orange and/or yellow coaxial cables connected to the MIC/CW LEVEL control open or shorted.</li> <li>E. Wafer 1F or 1R of the MODE switch wired incorrectly.</li> <li>F. MIC connector wired wrong.</li> <li>G. Speech amplifier tube V1 defective.</li> <li>H. Microphone defective.</li> <li>I. MIC/CW LEVEL control defective.</li> </ul>
<p>29. No RF output with the MODE switch in TUNE or CW, but output in LSB or USB OK.</p>	<ul style="list-style-type: none"> <li>A. Check items 19A, 19B, 20B, 20C, 29B, 30C, 30D, and 30E.</li> <li>B. MIC/CW LEVEL control defective.</li> <li>C. Rear wafer of MODE switch wired wrong.</li> </ul>
<p>30. No carrier oscillator injection signal with the MODE switch in TUNE or CW positions, but LSB and USB output OK.</p>	<ul style="list-style-type: none"> <li>A. Check items 19A and 19B.</li> <li>B. CW crystal Y3 improper frequency or defective.</li> <li>C. Lugs 1, 5, and/or 9 of the MODE switch wired incorrectly.</li> <li>D. Incorrect wiring of MODE switch wafers 1F or 2R.</li> <li>E. Tube V16 defective.</li> </ul>
<p>31. No carrier oscillator injection signal with the MODE switch in either LSB or USB positions. TUNE and CW output OK.</p>	<ul style="list-style-type: none"> <li>A. Check items 19A and 19B.</li> <li>B. Black coaxial cable from IF circuit board to modulator circuit board shorted.</li> <li>C. USB crystal Y1, or LSB crystal Y2, improper frequency or defective.</li> <li>D. Capacitors C4 through C8, C16 and C17, wrong value.</li> <li>E. Resistors R6 through R9, or R11, wrong value.</li> <li>F. Tube V16 defective.</li> </ul>
<p>32. Very low output in USB or LSB modes.</p>	<ul style="list-style-type: none"> <li>A. FILTER switch in CW position.</li> <li>B. Microphone output level or impedance too low.</li> </ul>



SYMPTOMS	POSSIBLE CAUSE
<p>33. No LMO injection signal at cathodes of V5 or V12.</p>	<ul style="list-style-type: none"> <li>A. Check items 5A, 5B, and 5C.</li> <li>B. FREQ CONTROL switch not in the LMO position, or wired wrong.</li> <li>C. The violet, orange, or white coaxial cables connected to the FREQ CONTROL switch, or the coaxial cable between the FREQ CONTROL switch and the LMO, wired incorrectly, shorted, or open.</li> <li>D. LMO tube V20 defective. NOTE: If this tube has to be replaced, use a tube from the same manufacturer.</li> <li>E. Defective LMO unit. If after making all the above checks it is determined that the LMO unit is defective, return the complete LMO to the Heath Company. See Page 15 of the Kit Builders Guide.</li> </ul>
<p>34. LMO frequency does not shift properly with MODE switch in various positions.</p>	<ul style="list-style-type: none"> <li>A. Check items 2A, 2B, 2C, 5A, 5B, 5C, 30B, 30D, 31C, 32D, and 32E.</li> <li>B. MODE switch wafer 1F wired incorrectly.</li> <li>C. Resistor R306 or R307 wrong value.</li> </ul>
<p>35. No heterodyne oscillator injection signal at cathodes of V6 and V11.</p>	<ul style="list-style-type: none"> <li>A. Check items 5A, 5B, and 5C.</li> <li>B. One of the crystals Y501 through Y508 defective, depending on the band being used.</li> <li>C. Red coaxial cable from heterodyne oscillator circuit board to bandpass circuit board, open or shorted.</li> <li>D. Capacitors C208 or C223 wrong value.</li> <li>E. Tube V19 defective or wrong type.</li> <li>F. Coils L601 through L608 misaligned or faulty.</li> <li>G. Capacitor C604 wrong value.</li> <li>H. No 150 V B+ voltage to the heterodyne oscillator circuit board.</li> <li>I. Rotors reversed 180 degrees in the switch wafer on the crystal or heterodyne oscillator circuit boards.</li> </ul>
<p>36. Relays RL1 and RL2 do not energize with the MODE switch in the TUNE position.</p>	<ul style="list-style-type: none"> <li>A. Tube V12B defective.</li> <li>B. Relays RL1 or RL2 defective.</li> <li>C. Wafer 2F of MODE switch wired incorrectly.</li> </ul>

SYMPTOMS	POSSIBLE CAUSE
<p>36. Relays RL1 and RL2 will not energize with MODE switch in LSB or USB, and FUNCTION switch in VOX position.</p>	<p>A. Check items 10C, 10D, 10E, 28G through 28J, 35A, 35B, and 35C.            B. VOX SENSITIVITY control improperly adjusted.            C. Tube V17A defective or wrong type.            D. Diode D201 wrong type or installed backwards.            E. Zener diode D202 installed backwards or defective.            F. FUNCTION switch wired incorrectly. Check the red-red-white wire to lug 3.            G. ANTI-TRIP control set too high.            H. FUNCTION switch in the CAL position.</p>
<p>37. Relays energize and stay energized regardless of VOX SENSitivity control setting.</p>	<p>A. Check items 35B, 36D, and 36E.            B. Anti-trip rectifiers D1 and D2 installed backwards.            C. PTT switch on microphone stuck closed or shorted.            D. Key closed.</p>
<p>38. Transmitter tends to be unstable.</p>	<p>A. Final and/or driver neutralization not proper.            B. Mounting hardware for DRIVER PRESELECTOR capacitor not tight.            C. Mounting hardware for Modulator and RF driver circuit board not tight. Lockwashers between circuit boards and chassis left out.            D. Check items 16C and 16D.            E. Coils L802 through L805 and/or L801 misaligned.            F. Antenna impedance wrong.            G. Coil shield cover loose.            H. Ground clips for tube shields bent out.</p>
<p>39. Receiver has slow recovery from transmit condition.</p>	<p>A. Diode D101 defective.</p>
<p>40. Grid drive falls off.</p>	<p>A. Excessive heat due to restricted air circulation.            B. Incorrect bias setting.            C. Improper load to RF output.            D. Gassy 6146 tubes.</p>
<p>41. Zero setting of main tuning dial changes considerably from band to band.</p>	<p>A. 100 kHz calibrator is not set exactly at 100 kHz.</p>

## SPECIFICATIONS

### RECEIVER

Sensitivity. . . . .	Less than 0.5 microvolt for 10 db signal-plus-noise to noise ratio for SSB operation.
SSB Selectivity. . . . .	2.1 kHz minimum at 6 db down, 5 kHz maximum at 60 db down (3.395 MHz filter). (2:1 nominal shape factor at 60:6 db.)
CW Selectivity (With SBA-301-2 CW Filter Installed). . . . .	400 Hz minimum at 6 db down, 2.0 kHz maximum at 60 db down.
Input. . . . .	Low impedance for unbalanced coaxial input.
Output Impedance. . . . .	8 $\Omega$ speaker, and high impedance headphone.
Power Output. . . . .	2 watts with less than 10% distortion.
Spurious Response. . . . .	Image and IF rejection better than 50 db. Internal spurious signals below equivalent antenna input of 1 microvolt.

### TRANSMITTER

DC Power Input. . . . .	SSB: (A3a emission) 180 watt P.E.P. (normal voice: continuous duty cycle). CW: (A1 emission) 170 watts (50% duty cycle).
RF Power Output. . . . .	100 watts on 80 through 15 meters; 80 watts on 10 meters (50 $\Omega$ nonreactive load).
Output Impedance. . . . .	50 $\Omega$ to 75 $\Omega$ with less than 2:1 SWR.
Oscillator Feedthrough Or Mixer Products. . . . .	55 db below rated output.
Harmonic Radiation. . . . .	45 db below rated output.
Transmit-Receive Operation. . . . .	SSB: PTT or VOX. CW: Provided by operating VOX from a keyed tone, using grid-block keying.
CW Side-Tone. . . . .	Internally switched to speaker or headphones, in CW mode. Approximately 1000 cps tone.
Microphone Input. . . . .	High impedance with a rating of -45 to -55 db.
Carrier Suppression. . . . .	50 db down from single-tone output.
Unwanted Sideband Suppression. . . . .	55 db down from single-tone output at 1000 Hz reference.
Emissions not possible or not recommended. . . . .	A0, A2, A3, A3b, A4 through A9, F0 through F9, and P0 through P9.



Third Order Distortion. . . . .	30 db down from two-tone output.
RF Compression (TALC*). . . . .	10 db or greater at .1 ma final grid current.

**GENERAL**

Frequency Coverage. . . . .	3.5 to 4.0; 7.0 to 7.3; 14.0 to 14.5; 21.0 to 21.5; 28.0 to 28.5; 28.5 to 29.0; 29.0 to 29.5; 29.5 to 30.0 (megahertz).
Frequency Stability. . . . .	Less than 100 hertz per hour after 20 minutes warmup from normal ambient conditions. Less than 100 Hz for $\pm 10\%$ line voltage variations.
Modes Of Operation. . . . .	Selectable upper or lower sideband (suppressed carrier) and CW.
Visual Dial Accuracy. . . . .	Within 200 Hz on all bands.
Electrical Dial Accuracy. . . . .	Within 400 Hz after calibration at nearest 100 kHz point.
Dial Mechanism Backlash. . . . .	Less than 50 Hz.
Calibration. . . . .	100 kHz crystal.
Audio Frequency Response. . . . .	350 to 2450 Hz.
Phone Patch Impedance. . . . .	8 $\Omega$ receiver output to phone patch; high impedance phone patch input to transmitter.
Front Panel Controls. . . . .	Main (LMO) tuning dial. Driver tuning and Preselector. Final tuning. Final loading. Mic and CW Level control. Mode switch. Band switch. Function switch. Freq Control switch. Meter switch. RF Gain control. Audio Gain control. Filter switch.

\*Triple Action Level Control™

Internal Controls. . . . .	VOX Sensitivity. VOX Delay. ANTI-TRIP. Carrier Null (control and capacitor). Meter Zero control. CW tone volume. Relative Power Adjust control. Bias. Phone Vol (headphone volume). Neutralizing.
Tube Complement. . . . .	OA2 Regulator (150 V). 6AU6 RF amplifier. 6AU6 1st receiver mixer. 6AU6 Isolation amplifier. 6AU6 1st IF amplifier. 6AU6 2nd IF amplifier. 6BN8 Product detector and AVC. 6CB6 LMO. 6CB6 2nd transmitter mixer. 6CL6 Driver. 6EA8 Speech Amplifier and cathode follower. 6EA8 1st transmitter mixer and crystal oscillator. 6EA8 2nd receiver mixer and relay amplifier. 6EA8 CW side-tone oscillator and amplifier. 6GW8 Audio amplifier and audio output. 12AT7 Heterodyne oscillator and cathode follower. 12AT7 VOX amplifier and calibrator oscillator. 12AU7 Sideband oscillator. 6146 Final amplifiers (2).
Diode Complement. . . . .	6 Germanium Diodes: Balanced modulator, RF sampling, and crystal calibrator harmonic generation. 9 Silicon Diodes: ALC rectifiers, anti-trip rectifiers, and DC blocking. 1 Zener Diode: cathode bias.

Rear Apron Connections. . . . .	CW Key jack. 8 $\Omega$ output. Phone patch input. ALC input. Power and accessory plug. RF output. Antenna switch. Receiver Antenna. Spare A. Spare B.
Power Requirements. . . . .	700 to 850 volts at 250 ma with 1% maximum ripple. 300 volts at 150 ma with .05% maximum ripple. -115 volts at 10 ma with .5% maximum ripple. 12 volts AC/DC at 4.76 amps.
Cabinet Dimensions. . . . .	14-7/8" wide x 6-5/8" high x 13-3/8" deep.
Net Weight. . . . .	17-1/2 lbs.
Equipment Used To Prepare Specifications. . . . .	Heath HN-31 "Cantenna." Heath SB-610 Monitor Scope. Heath IM-11 VTVM. Heath MM-1 VOM. Heath IG-72 Audio Generator. Heath HDP-21A Microphone. Hewlett-Packard Electronic Counter, Model 524B. Tektronix Oscilloscope, Model 581A. Hewlett-Packard Signal Generator, Model 606A. Panoramic Radio Products Inc., "Panalyzer," Model SB-12A. Boonton RF Voltmeter, Model 91-CA. Dynascan Digital Voltmeter, Model 111.

The Heath Company reserves the right to discontinue instruments and to change specifications at any time without incurring any obligation to

incorporate new features in instruments previously sold.

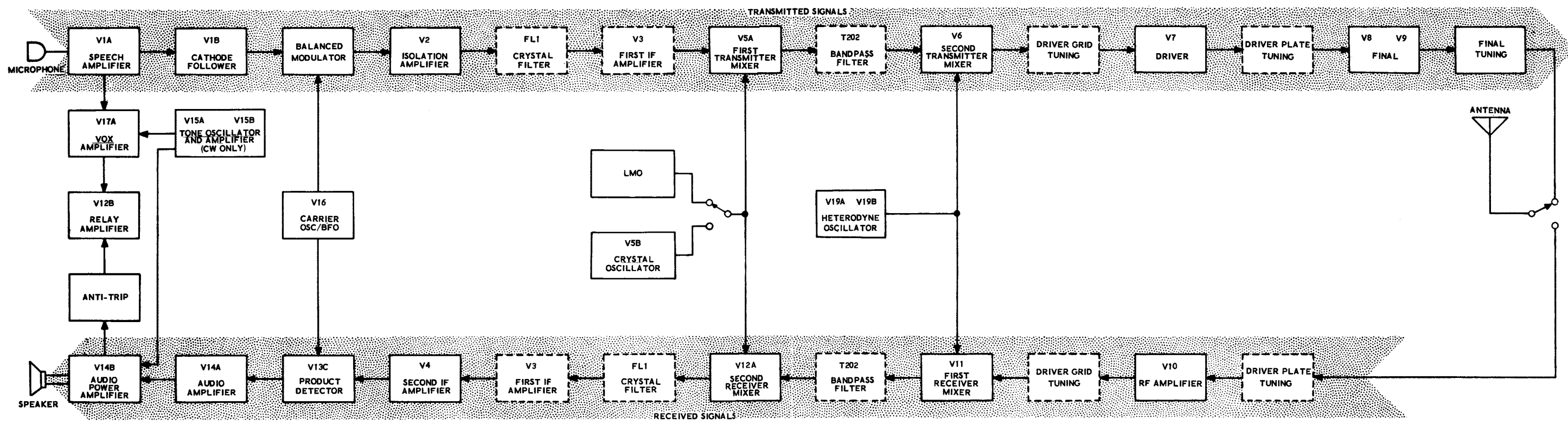

THESE BLOCKS ARE FOR THE CIRCUITS THAT ARE USED IN BOTH THE TRANSMITTER AND RECEIVER MODES OF OPERATION.

**BLOCK DIAGRAM**

## CIRCUIT DESCRIPTION

Refer to the Block Diagram (fold-out from Page 124) and to the Schematic (fold-out from Page 151) while reading the Circuit Description. Small sections of the Schematic are also included in this Description to make the circuits easier to follow.

Note that the receiver circuits are across the bottom, and the transmitter circuits are across the top of the Schematic and Block Diagrams. Also, several of the circuits that are used for transmitting are also used for receiving (such as the crystal filter and the first IF amplifier). These circuits, which are shown in both the transmitter and receiver portions of the Block Diagram, are identified in the Block Diagram by dotted lines.

Each rotary switch wafer is identified by the front panel name of the switch, and by a letter-number designation that shows the position of that wafer in the switch. See Figure 2-1.

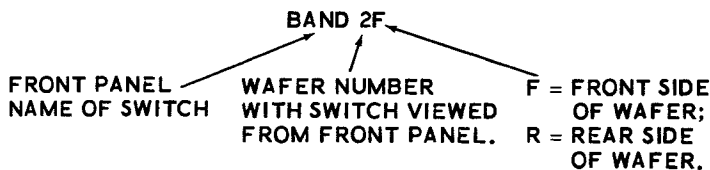

Figure 2-1

Letter number designations for the resistors, capacitors, coils, etc., are placed in the following groups:

0- 99	Parts on modulator circuit board.
100-199	Parts on IF circuit board.
200-299	Parts on bandpass circuit board.
300-399	Parts on audio circuit board.
400-499	Parts on RF-driver circuit board.
500-599	Parts on crystal circuit board.
600-699	Parts on heterodyne oscillator circuit board.
700-799	Parts on driver grid circuit board.
800-899	Parts on driver plate circuit board.
900-999	Parts mounted on the chassis.

### TRANSMITTER CIRCUITS

The chart in Figure 2-2 lists the various frequencies that will be found throughout the transmitter on each band. The transmitted lower side-band frequency of 3,895 MHz, modulated with a 1400 hertz audio tone, which is shown on the first line, will be used when tracing through the transmitter circuits. The other frequencies referred to in this Circuit Description will also be found on the first line.

BAND	CARRIER OSCILLATOR (3393.6 kHz plus 1400 Hz modulation), CRYSTAL FILTER AND IF FREQUENCIES	LMO FREQUENCY (BETWEEN 5 AND 5.5)	SIGNAL FREQUENCY AT BANDPASS FILTER (BETWEEN 8.395 AND 8.895)	HETERODYNE OSCILLATOR FREQUENCY (CRYSTAL FIXED)	TRANSMITTED SIGNAL FREQUENCY
3.5 to 4	3.395	5.105	8.5	12.395	3.895
7 to 7.5	3.395	5.3	8.695	15.895	7.2
14 to 14.5	3.395	5.3	8.695	22.895	14.2
21 to 21.5	3.395	5.2	8.595	29.895	21.3
28 to 28.5	3.395	5.4	8.795	36.895	28.1
28.5 to 29	3.395	5.3	8.695	37.395	28.7
29 to 29.5	3.395	5.3	8.695	37.895	29.2
29.5 to 30	3.395	5.4	8.795	38.395	29.6

All frequencies are in MHz.

Figure 2-2



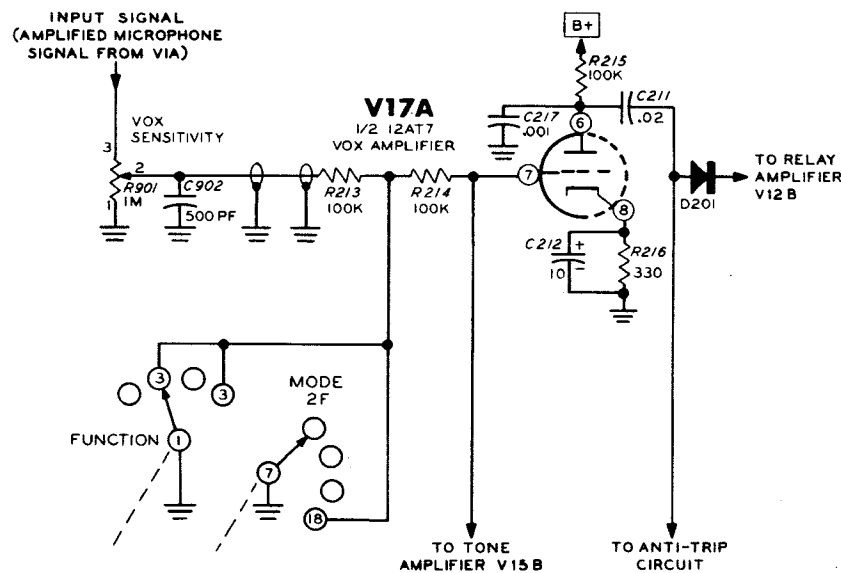

Figure 2-3

### VOX Amplifier (Figure 2-3)

The Transceiver can be switched from receive to transmit by either the VOX (voice operated transmitter) or the push-to-talk method. The VOX circuit works in the following manner:

The audio signal from the microphone is coupled through speech amplifier V1A and capacitor C9 to the VOX Sensitivity control. From the arm of this control, for VOX operation, the signal is coupled through resistors R213 and R214 to the grid of VOX amplifier V17A. The signal is amplified in V17A. It is then coupled through capacitor C211, rectified by diode D201, and applied to relay amplifier V12B, which actuates the transmit-receive relays.

In the PTT and Calibrate positions of the Function switch, and in the CW position of the Mode switch, the lead from the VOX Sensitivity control to the grid of V17A is connected to ground. This keeps stray microphone signals from activating the VOX circuit during PTT and CW operation, or during calibration.

### Relay Amplifier (Figure 2-4)

Relay amplifier V12B is held in cutoff during receive operation by the positive voltage that is maintained at its cathode by zener diode D202. V12B is made to conduct for transmit operation by the VOX voltage at its grid, or by the push-to-talk switch on the microphone which shorts the cathode to ground. (The cathode of V12B is also shorted to ground by wafer 2F of the Mode switch in the Tune position.) Diode D201 rectifies the audio signal from the VOX amplifier so that a positive voltage appears at the grid of relay amplifier V12B. The positive voltage at the grid causes the relay amplifier to conduct, and the plate current of V12B causes relays RL1 and RL2 to close and place all circuits in the transmit mode of operation.

The VOX hold-in time is adjusted by varying the discharge time for capacitor C213 with the VOX Delay control.

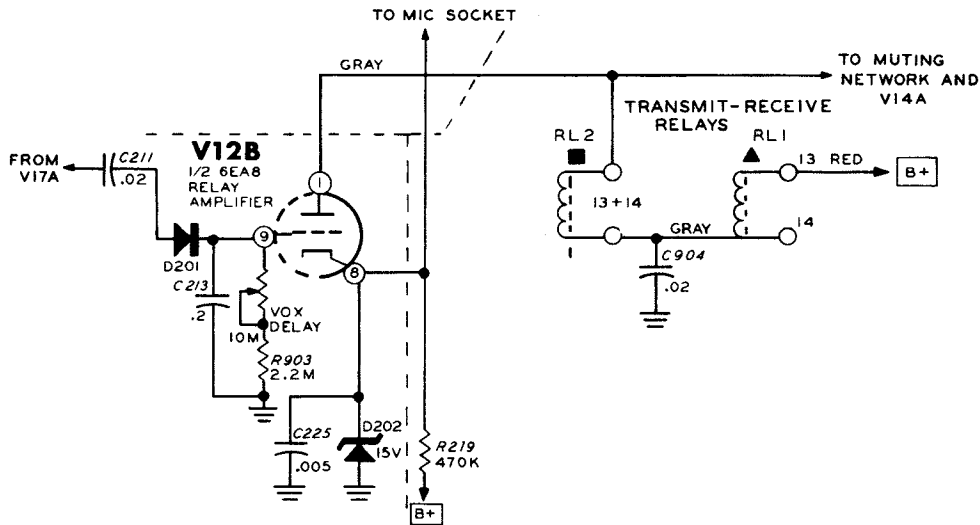

Figure 2-4

**Anti-trip Circuit (Figure 2-5)**

The anti-trip circuit is used in the receive mode of operation to keep the speaker signals from activating relay amplifier V12B.

An audio signal is coupled through capacitor C305 from audio power amplifier V14B to the Anti-Trip control. This audio signal is then

coupled through isolation resistor R25 and rectified by diodes D1 and D2, resulting in a negative DC voltage across capacitor C25 and resistor R16. This negative voltage is then coupled through resistor R27 to the grid circuit of relay amplifier V12B, where it cancels out the positive voltage from the VOX amplifier. Thus, with no positive voltage at its grid, relay amplifier V12B remains cut off, and the relays remain in the receive position.

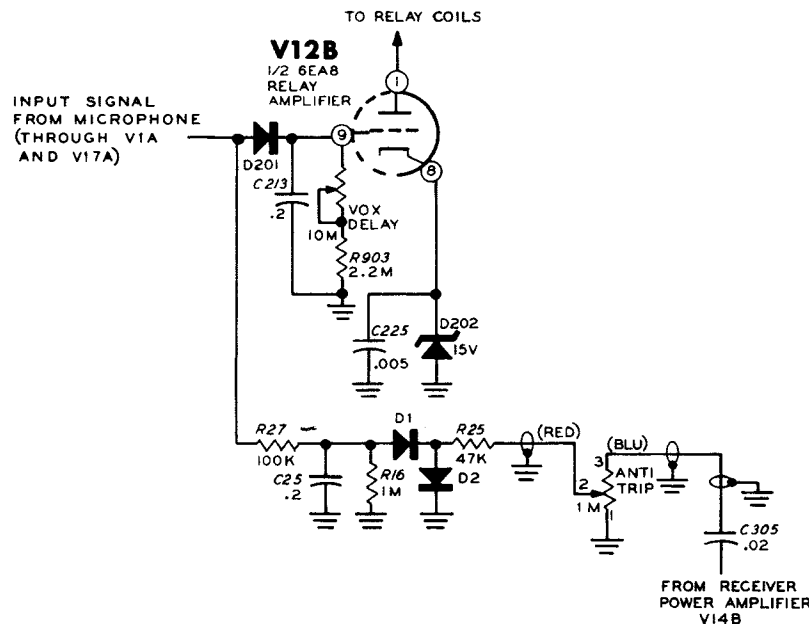

Figure 2-5

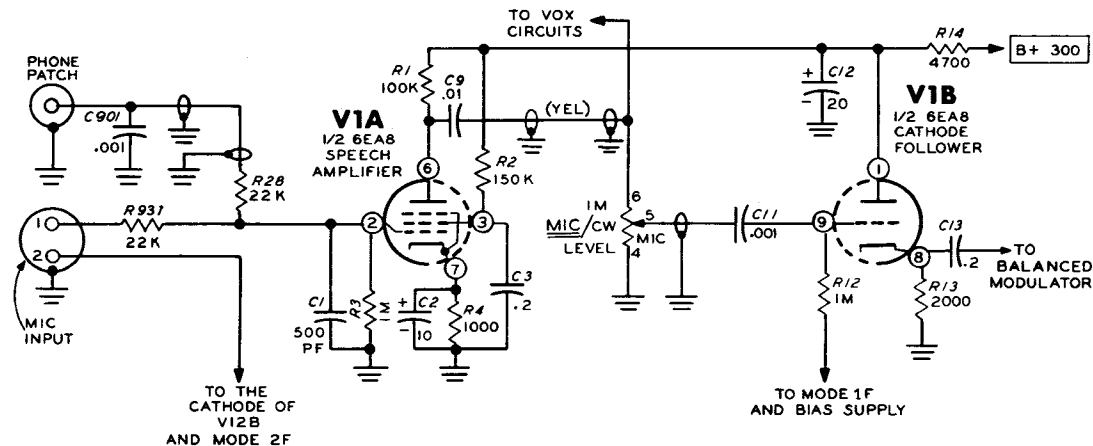

Figure 2-6

### Speech Amplifier And Cathode Follower (Figure 2-6)

The audio signal from the microphone is coupled directly from lug 1 of the Microphone input socket to the grid of speech amplifier V1A. Lug 2 of the Microphone input socket is returned to ground through the push-to-talk switch on the microphone. The cathode of relay amplifier V12B is also connected to lug 2 so it will be returned to ground when the push-to-talk switch is depressed, to operate the transmit relays.

Capacitor C1, at the grid of V1A, limits the high frequency response of this stage and passes to ground any RF signals present at this point. The amplified signal from the plate of V1A is coupled through capacitor C9 to the Microphone Level section of the Mic/CW Level control and also to the VOX amplifier circuit.

The setting of the Microphone Level control determines the amount of modulation since it adjusts the amount of speech signal that is coupled through cathode follower V1B to the balanced modulator circuit. For LSB and USB operation, V1B grid resistor R12 is returned to ground through wafer 1F of the Mode switch and contacts 6 and 10 of relay RL2. When the

Mode switch is in the Tune or CW position, cathode follower V1B is cut off by a bias voltage that is supplied to it from the junction of bias voltage divider resistors R308 and R309.

### Carrier Oscillator (Figure 2-7)

The carrier oscillator consists of two Colpitts crystal oscillators. These oscillators supply an RF signal to the balanced modulator for transmit operation, and a heterodyne signal to product detector stage V13 for receive operation. Tube V16A and crystal Y1 (3396.4 kHz) serve as the USB (upper sideband) carrier oscillator, and tube V16B with crystals Y2 (3393.6) and Y3 (3395.4 kHz) acts as the LSB (lower sideband) and CW carrier oscillator.

The desired carrier oscillator, V16B for the transmitted frequency being used in this Description (3393.6 kHz), is placed in operation by wafer 1R of the Mode switch which connects its plate circuit to B+. Wafer 2R of the Mode switch connects the proper crystal to the grid of V16B: Y2 for LSB operation and Y3 for tune or CW transmit operation.

When the Mode switch is in the CW position, B+ is connected through part of relay RL1 to either V16A or V16B.

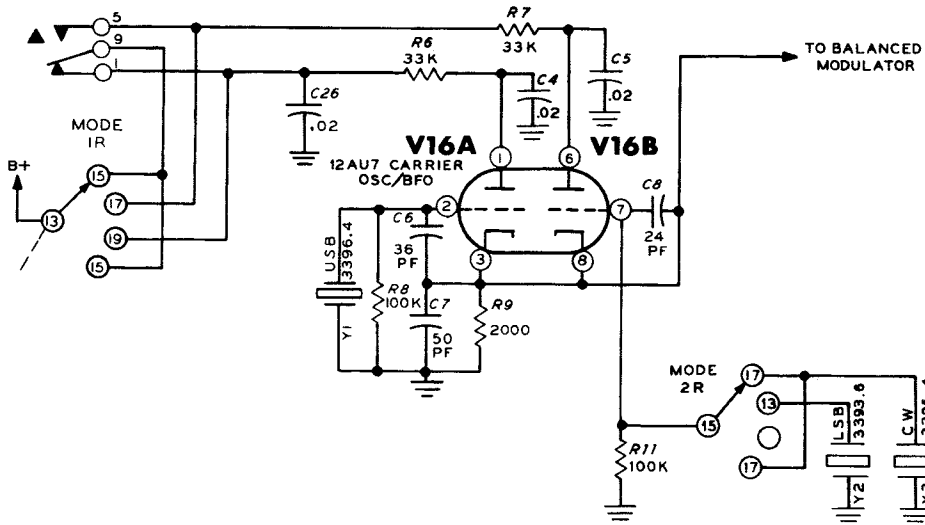

Figure 2-7

For receiving CW signals, lugs 9 and 1 of relay RL1 place tube V16B and crystal Y1 in operation. For transmitting CW, lugs 9 and 5 of relay RL1 place tube V16B and Crystal Y3 in operation.

When receiving CW signals, the receiver is automatically tuned 1 kHz below the incoming signal (this signal is zero beat against your transmitting frequency) by V16A and crystal Y1, which are used as a BFO (beat frequency oscillator). When transmitting, tube V16B and crystal Y3 cause the output signal of the Transceiver to be at the same frequency as the incoming signal from the other station.

**Balanced Modulator (Figure 2-8)**

Diodes CR1, CR2, CR3, and CR4, are connected in a ring type balanced modulator circuit. When the audio signal from cathode follower V1B and the RF signal from carrier oscillator V16 are applied to this balanced modulator, two additional frequencies are produced: one is equal to the sum of the audio and carrier frequencies; and the other is equal to the difference between them. These sum and difference frequencies are the upper and lower sidebands; and only these upper and lower sideband signals appear at the output of the balanced modulator circuit.

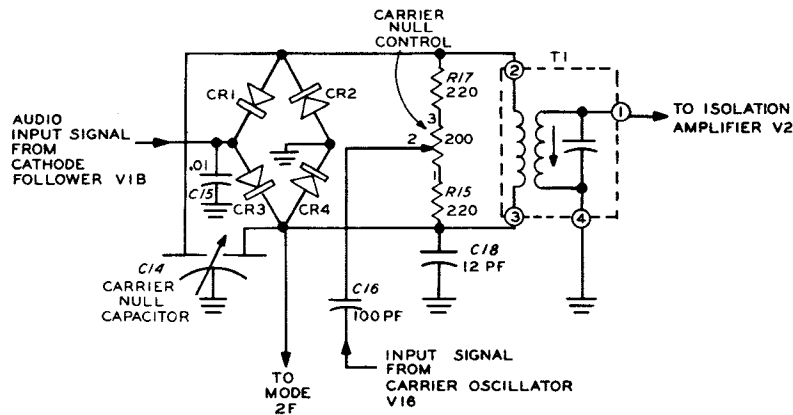

Figure 2-8

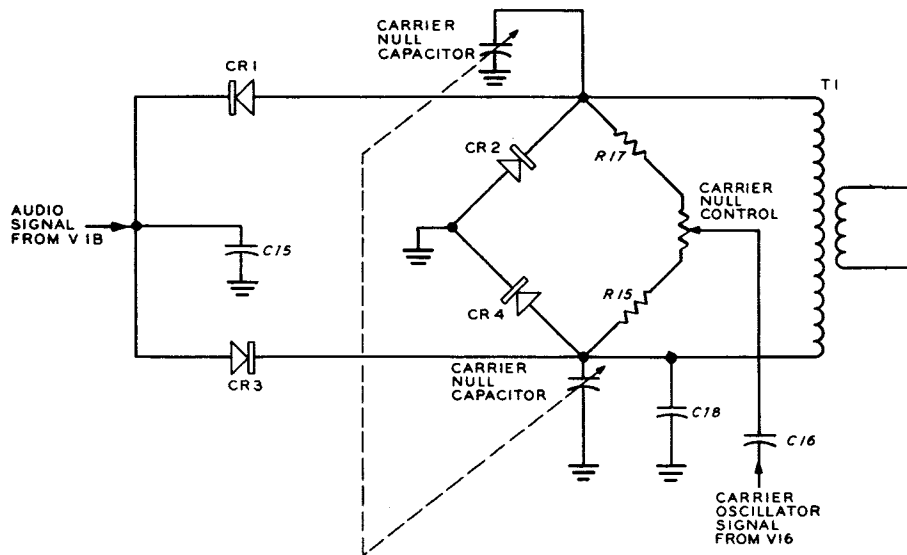

Figure 2-9

The 3393.6 kHz carrier oscillator signal is applied through capacitor C16 and across a bridge circuit that consists of the Carrier Null control, resistors R15 and R17, and diodes CR1, CR2, CR3 and CR4 of the modulator diode ring. See Figure 2-9. The carrier signal is balanced out by the Carrier Null control and the Carrier Null capacitor; so there is no output signal from this circuit (until an audio signal is applied).

The audio signal that is coupled to diodes CR1, CR2, CR3, and CR4 from cathode follower V1B unbalances the modulator at an audio rate, causing the sum and difference sideband frequencies to appear at the output of balanced modulator transformer T1. When no audio signal appears at the input, there is no output signal from the balanced modulator circuit. Capacitor C15 is an RF bypass.

When the Mode switch is turned to the CW position, wafer 2F connects one side of the diode ring to ground. This ground connection unbalances the nulled circuit and the unbalance causes an RF output signal to be produced at the secondary of balanced modulator transformer T1. This signal is then coupled through capacitor C22 to isolation amplifier V2. The secondary of transformer T1 is tuned to the CW carrier frequency.

#### Isolation Amplifier (Figure 2-10)

Both the upper and lower sideband signals from the balanced modulator circuit are coupled through capacitor C22 to the cathode of isolation amplifier V2. V2 isolates the balanced modulator circuit from the crystal filter, and provides proper impedance matching to the crystal filter. The gain of isolation amplifier V2 is varied by the ALC (automatic level control) voltage that is connected to its grid circuit through resistors R21 and R22. The complete ALC circuit will be described later under the heading ALC Circuit.

When transmitting, the output of V2 is coupled through capacitor C506 to the crystal filter. In the CW mode of operation, the gain of V2 is controlled by the CW section of the Mic/CW Level control. This control supplies a variable negative bias to the grid of V2 through wafer 1R of the Mode switch and resistors R22 and R21.

B+ is supplied to the screen of V2 in the transmit mode only, through resistor R937 and contacts 7 and 11 of relay RL2.

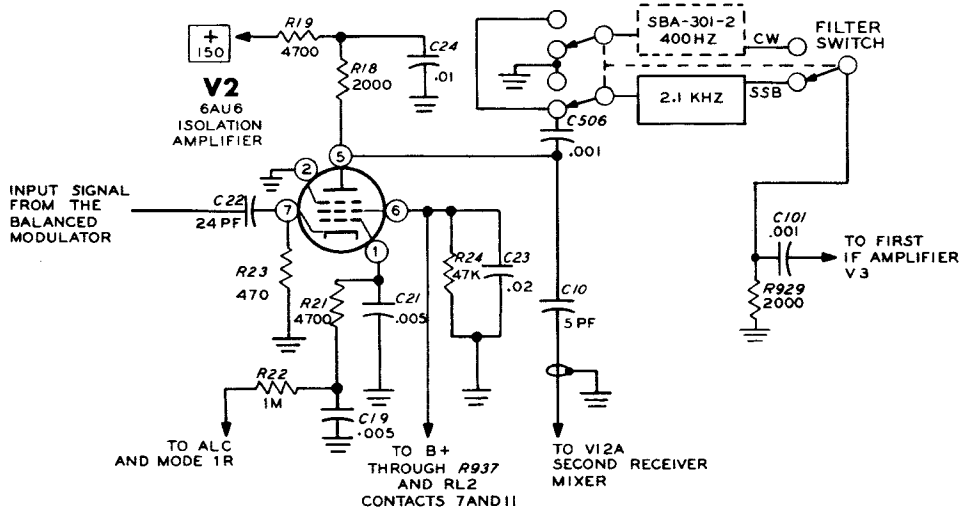

Figure 2-10

**Crystal Filter (Figure 2-11)**

Crystal filter FL1 has a center frequency of 3395 kHz and a usable bandwidth of 2.1 kHz (3393.95 kHz to 3396.05 kHz at the 6 db points). See Figure 2-11. This filter, in the LSB mode of operation, passes only the sum frequencies (the 3393.6 kHz carrier frequency plus all the audio frequencies from 350 to 2450 Hz), which contain the upper sideband intelligence. The carrier frequency itself, as shown in Figure 2-11, is further reduced 20 db by the crystal filter. This attenuation plus the attenuation of the balanced modulator gives an ultimate carrier attenuation of at least 50 db. (The apparent frequency discrepancy here in sidebands and carrier is overcome later, when the sidebands are inverted in the second mixer.)

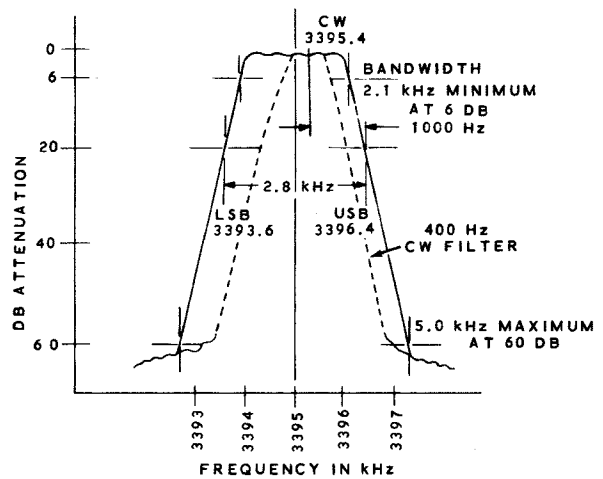
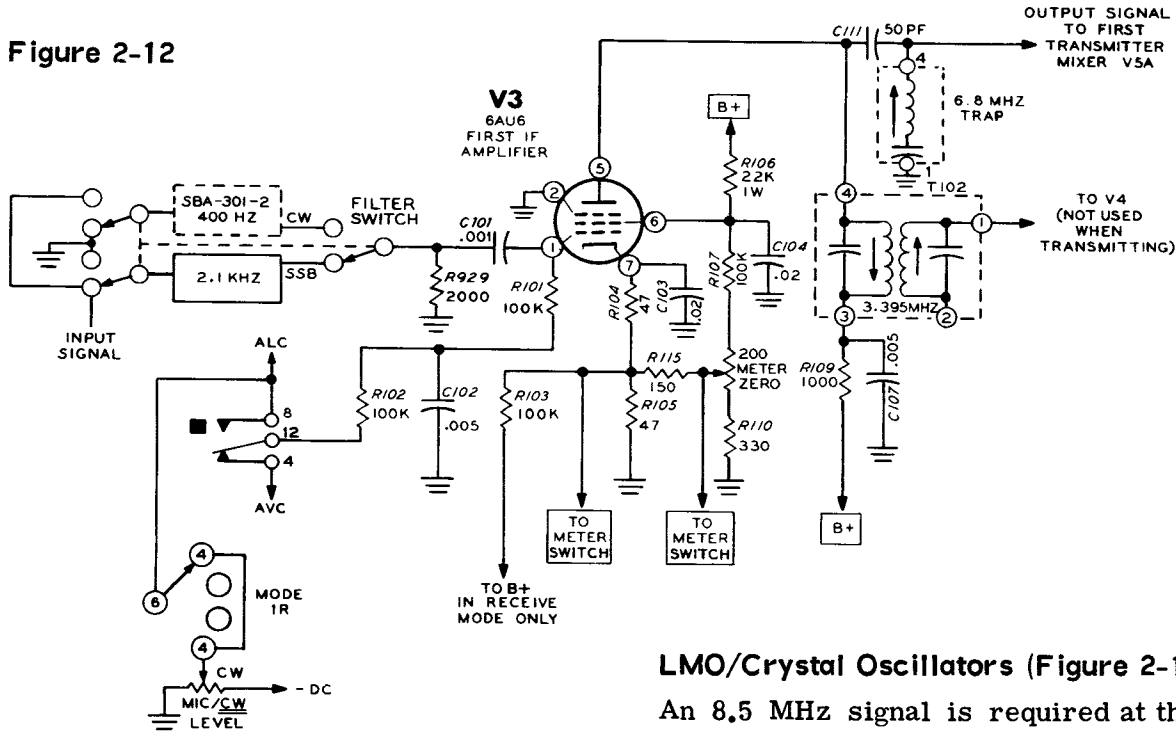

Figure 2-11

In the USB Mode, the filter passes only the difference frequencies (the 3396.5 kHz carrier oscillator frequency minus the audio frequencies from 350 to 2450 Hz); this contains the lower sideband intelligence. In the CW Mode, a carrier of 3395.4 kHz passes through the crystal filter with no attenuation.

If the SBA-301-2 Accessory CW Crystal Filter is installed, the signal also passes through it when the Filter switch is in CW. The 400 Hz bandpass of the CW Filter will not pass the normal audio range, therefore making SSB signals unintelligible.

Figure 2-12



**IF Amplifier (Figure 2-12)**

IF Amplifier V3 amplifies the signal received from crystal filter FL1. The second IF amplifier, V4, is not used in transmit operation. IF transformer T102, which is tuned to 3,395 mc, acts as the plate load for V3. The output signal from V3 is then coupled through capacitor C111 to the grid of first transmitter mixer stage V5A. The 6.8 MHz trap is used to remove the second harmonic of the 3,395 MHz signal.

ALC voltage is applied through lugs 8 and 12 of relay RL2 to the grid circuit of V3 to provide automatic level control for the transmitted signal. When the Mode switch is in the CW and Tune positions, the gain of IF amplifier V3 is controlled by a variable DC bias applied to its grid. This bias voltage, which originates at the arm of the Mic/CW Level control, is coupled to V3 through wafer 1R of the Mode switch, and through lugs 8 and 12 of relay RL2.

The front panel meter, in the ALC position, is connected in a DC bridge between the screen and cathode circuits of V3. The meter circuits are explained separately on Page 144 of this Circuit Description.

**LMO/Crystal Oscillators (Figure 2-13)**

An 8.5 MHz signal is required at the output of first mixer tube V5A to produce the correct output frequency on the 3.5 to 4 MHz band, which is being used in this Circuit Description. This 8.5 signal is obtained by mixing the 3,395 MHz IF signal at the grid of V5A with the oscillator signal that is applied to its cathode from the Freq control switch.

The Freq Control switch receives signals from the LMO (linear master oscillator), or from crystal oscillator V5B. The LMO is a very stable variable oscillator that can be continuously tuned linearly over a frequency range of 5 to 5.5 MHz. Crystal controlled Colpitts oscillator V5B may be switched into the circuit in place of the LMO for crystal controlled operation of the Transceiver.

The Freq Control switch performs the following functions: In the LMO position, the signal is connected from the LMO to first transmitter mixer V5A and to first receiver mixer V11. In the Locked AUX position the output of crystal oscillator V5B is connected to first transmitter mixer V5A and to second receiver mixer V12A. In the Unlocked AUX position, the output of crystal oscillator V5B is connected to first transmitter mixer V5A, and the LMO output is connected to second receiver mixer V12A.

The term Locked means that the transmitter and receiver sections are controlled by a common oscillator. This causes them to always be locked on identical frequencies.

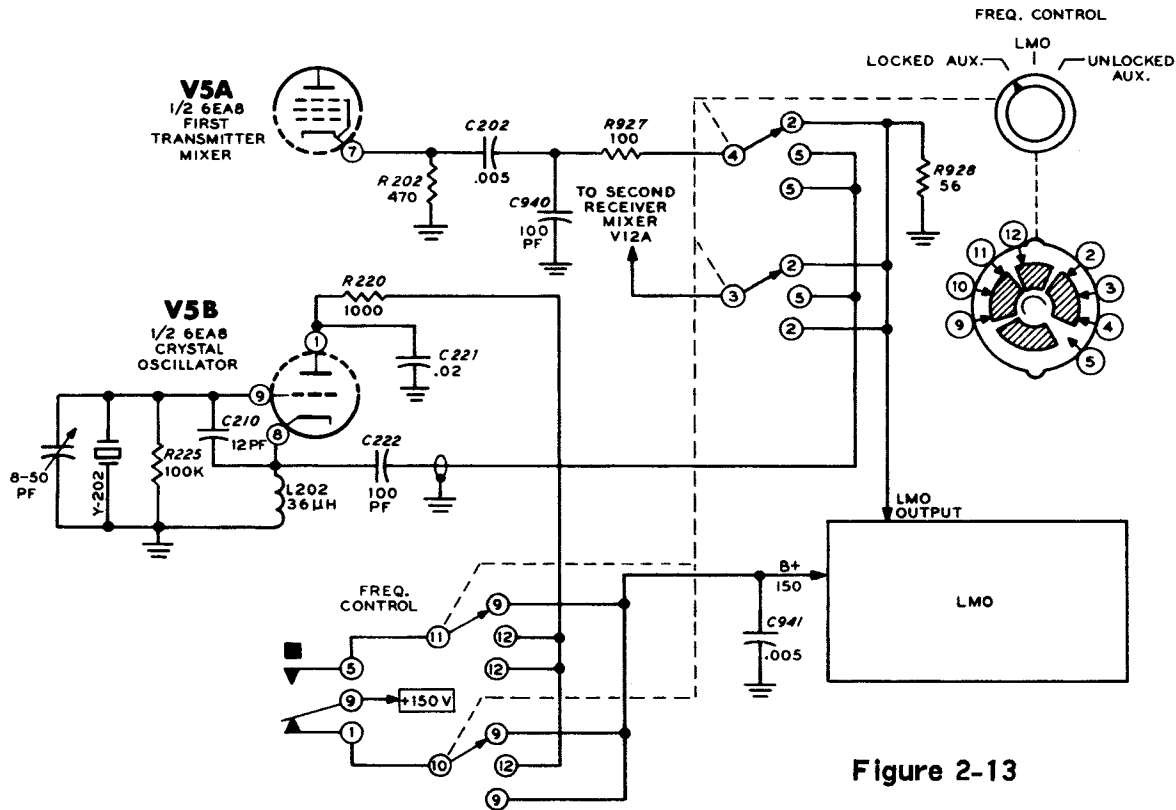

Figure 2-13

The term Unlocked means that the Transmitter and receiver sections are controlled by separate oscillators and their frequencies may differ.

**First Transmitter Mixer (Figure 2-14)**

The 3.395 MHz IF signal at the grid, and the 5.105 MHz LMO signal (or crystal oscillator signal) at the cathode, are mixed in first transmitter mixer tube V5A to produce sum and difference frequencies. The 8.5 MHz sum of these two signals is coupled from the plate of V5A through bandpass filter T202 to second transmitter mixer V6.

The Bandpass filter T202 is tuned to pass only those signal frequencies between 8.395 and 8.895 MHz; all other frequencies are attenuated. Only the 8.5 MHz sum of the IF and LMO signals falls within this frequency range, so it only is passed on to the second mixer.

First transmitter mixer V5A, second transmitter mixer V6, and driver V7 are cut off during the receive mode of operation by a negative voltage that is applied to their grids through diode D301 and resistor R301. This negative voltage is removed for the transmit mode by contacts 6 and 10 of relay RL2, which cause the cathode side of diode D301 to be grounded.

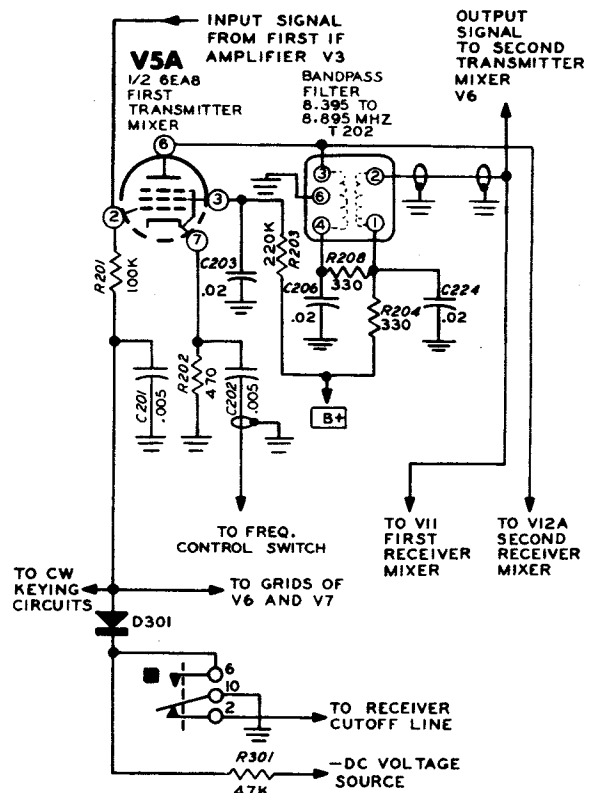

Figure 2-14



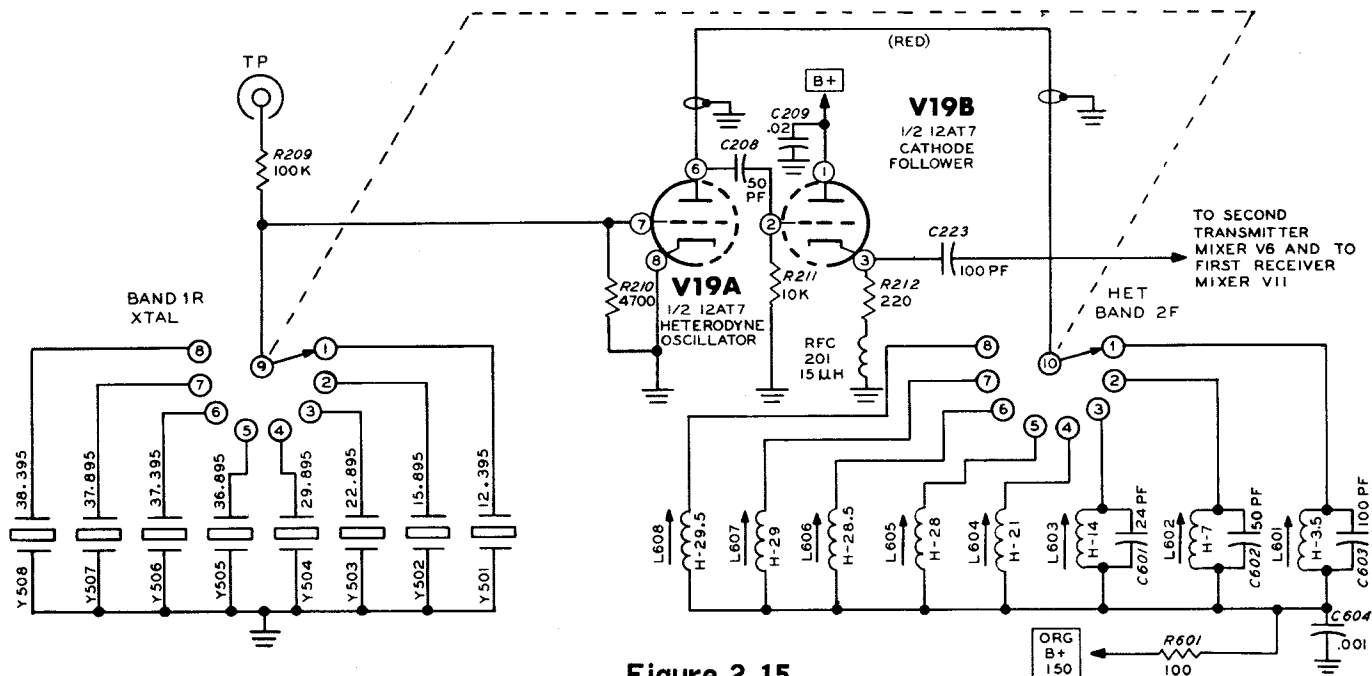

Figure 2-15

**Heterodyne Oscillator and Cathode Follower (Figure 2-15)**

Heterodyne Oscillator V19A operates as a tuned-plate crystal oscillator. The proper plate coil for each band, L601 through L608, is selected by wafer 2F on the Band switch. The output signal from the plate of the oscillator is coupled through cathode follower V19B to the cathode of second transmitter mixer V6 and to the cathode of first receiver mixer V11. The correct oscillator crystal for each band is selected by wafer 1R of the Band switch. The crystals below 20 mc are fundamental cuts, and the higher frequency crystals operate on their third overtones.

The grid voltage of V19A can be metered at TP to check oscillator activity.

**Second Transmitter Mixer (Figure 2-16)**

The 8.5 MHz signal from the first transmitter mixer and bandpass filter is coupled to the grid of second mixer tube V6. The 12,395 MHz output from the heterodyne oscillator is coupled to the cathode of V6. These signals are mixed in V6 to produce the operating frequency.

The frequency of the tuned plate circuit of second mixer V6 is the operating frequency. All other frequencies are shorted to ground.

In this instance, the difference between the 8.5 MHz input frequency and the 12,395 MHz heterodyne oscillator frequency results in a second mixer output frequency of 3,895 MHz. This output signal is coupled to the grid of driver stage V7.

The 3.5 MHz plate tuning coil, L701, is connected across the plate tuned circuit on all bands, along with the fixed and variable tuning capacitors. Band switch wafer 3F connects the correct amount of inductance in parallel with L701 to tune each band, except the 3.5 MHz (80 meter) band, which uses coil L701 only.

Tuning capacitor C421B is connected across the tuned circuit on all bands. Tuning capacitor C421A is connected in parallel with C421B on the 80 meter band only, by Band switch wafer 3R.

**Driver (Figure 2-17)**

Driver stage V7 amplifies the 3,895 MHz signal from second transmitter mixer V6 to a level that is sufficient to drive the final amplifiers.



### Final Amplifiers (Figure 2-18)

Final amplifier tubes V8 and V9 are connected in parallel and function as class AB1 linear amplifiers. A fixed negative bias is applied to the grids of these tubes through resistor R916 and choke L903. This bias limits zero-signal plate current. B+ is removed from the screen grids under receive conditions, by lugs 7 and 11 of relay RL2 to reduce the plate current to zero and cut off the tubes. RF driving voltage is developed across RF choke L903. Plate voltage is shunt fed through RF choke L901.

For the LSB and USB modes of operation, the peak driving voltage is controlled by the Microphone level control (in the grid circuit of V1B) and the limiting action of the ALC (automatic level control) voltage. This ALC voltage is fed back to isolation amplifier V2 and IF amplifier V3.

The output signal from V8 and V9 is coupled through RF parasitic chokes L904 and L902 and through capacitor C915 to the final tuning capacitor C925 and plate tank coils L905 and L906. The parasitic chokes eliminate any tendency toward VHF parasitic oscillation.

Wafer 5R of the Band switch connects the proper portion of the plate tank coil in the circuit for each band by shorting out the unused section. Wafer 5R also selects the proper combination of final tank tuning and loading capacitors for each band.

Neutralization of the final amplifier is accomplished by feeding a portion of the plate signal back to the grid through neutralizing capacitors C913 and C914, and across C801 in a bridge circuit.

The output signal from the final tank coil is coupled through lugs 8 and 12 of relay RL1 to the RF Out socket. The antenna switch allows separate transmit and receive antenna circuits to be used, so the Rec Ant socket can be connected to an external relay for use with linear amplifiers that do not have built-in antenna switching.

### ALC Circuit (Figure 2-18)

The ALC (automatic level control) bias voltage is developed from a small portion of the signal in the final amplifier stage. This signal is then rectified, filtered, and fed back to the preceding stages to adjust their gain automatically, as needed. ALC voltage assures maximum transmitter output without overloading.

The ALC voltage for this Transceiver is developed in the Heath TALC™ (Triple Action Level Control) circuit. This circuit keeps the transmitter from overloading, without causing the voice peaks to be flat-topped, by compressing the speech waveform. The triple action of this circuit is described below in paragraphs 1, 2, and 3.

1. Any peak voltages at the grids of final tubes V8 and V9 that drive the grids positive into grid current will develop bursts of voltage across resistor R916. This forms an audio-frequency AC that is coupled through capacitor C911 to voltage doubler rectifiers D902 and D903. The rectified negative output voltage goes to the ALC line.
2. The variations that occur in the final amplifier screen supply voltage on speech peaks produce a varying voltage which is coupled through capacitor C908 to rectifiers D902 and D903. This second voltage source produces additional ALC voltage.
3. The ALC voltage that is obtained from an external linear power amplifier can be applied through the ALC connector to rectifiers D902 and D903. With proper conditions, this source should have predominate control, thus holding down the drive in the Transceiver for best operation.

The rectified voltage from diode D903 is applied to an RC network consisting of resistors R914 and R915, and capacitors C931 and C932. This network filters the DC bias voltage, and allows it to build up quickly and decay slowly.

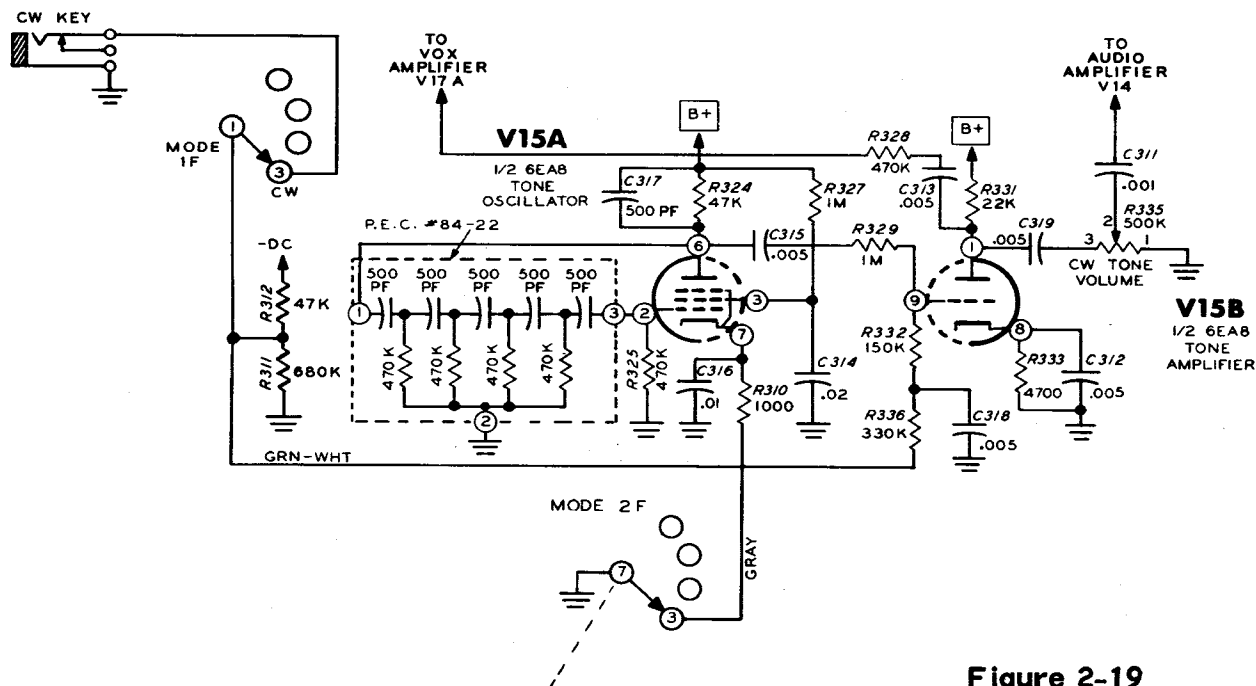

Figure 2-19

From the RC filter network, the ALC voltage is applied to the grid of isolation amplifier V2, where it limits the output, thus reducing the drive available to the final amplifiers. The ALC voltage is also coupled through lugs 8 and 12 of relay RL2 to IF amplifier V3.

ALC voltage is not developed for CW operation. Adjustable bias from the Mic/CW Level control is used instead.

### Tone Oscillator and Amplifier (Figure 2-19)

The tone oscillator circuit, V15, generates a 1000 Hz audio signal that is used for CW operation only. This tone is inserted into the VOX circuit to turn on the transmitter. It is also coupled to the receiver audio amplifier so the operator can monitor his transmitted signal.

Tone oscillator V15A is turned on when its cathode is connected to ground through wafer 2F of the Mode switch. The output frequency of V15A is determined by the phase-shift network (P.E.C. #84-22) in its grid circuit. From the plate of V15A, the 1000 Hz tone is coupled through capacitor C315 and resistor R329 to the grid of tone amplifier V15B.

Tone amplifier V15B is normally cut off by a negative bias that is applied to its grid from the junction of resistors R311 and R312. When the CW key is closed, this cut-off bias is removed (resistor R311 is shorted out through Mode switch wafer 1F and the key), and V15B conducts.

From the plate of V15B, the 1000 cps tone is coupled to the CW Tone Volume control, and from there to audio amplifier V14B. The 1000 cps tone is also coupled through capacitor C313 and resistor R328 to the grid of VOX amplifier V17A, where it causes the transmitter to be turned on.

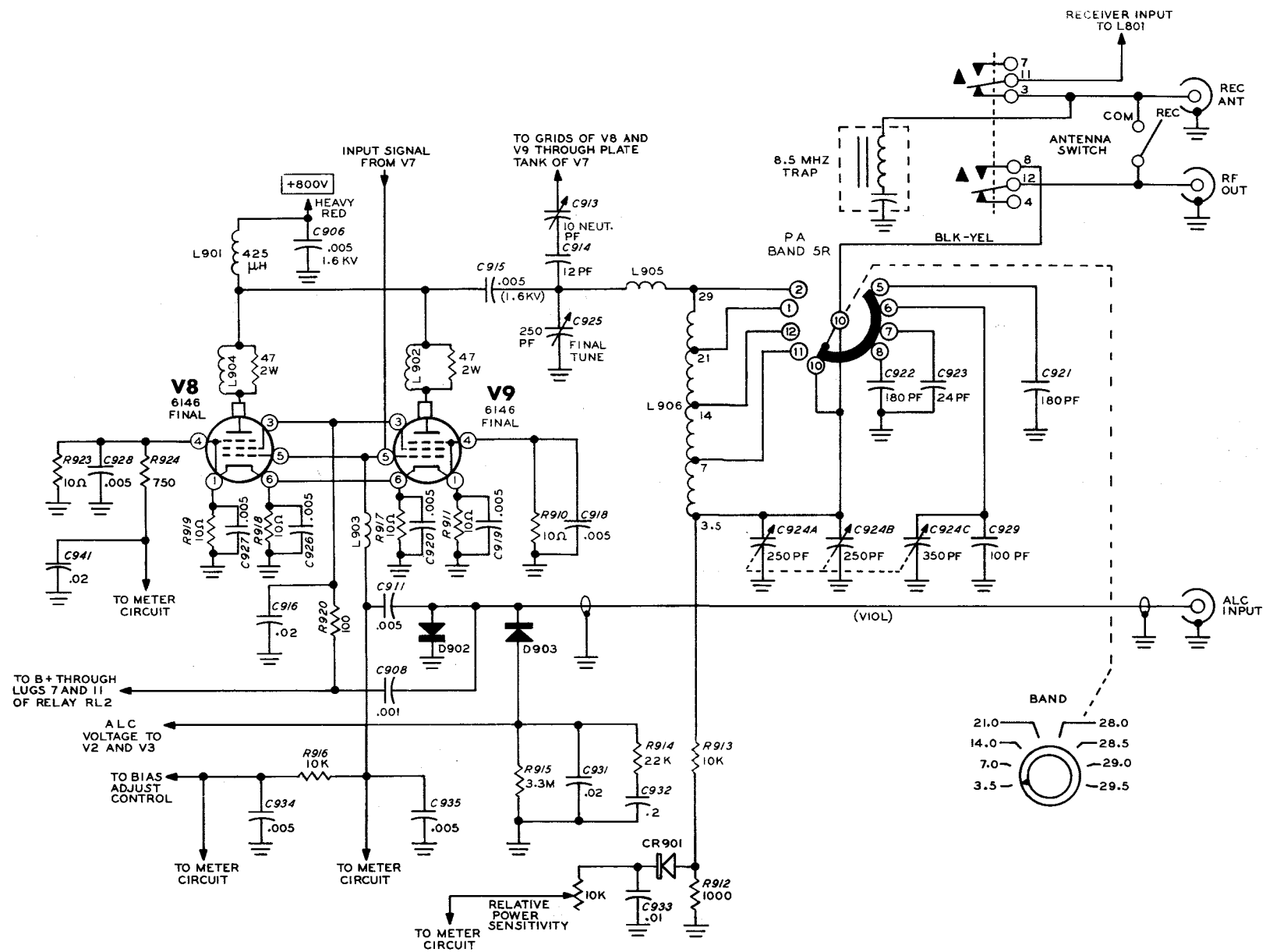

FIGURE 2-18

## CW Operation

When the Mode switch is turned to the CW position, the following circuit changes occur:

1. Cathode follower V1B is cut off and the arm of VOX Sensitivity control is grounded so stray microphone signals do not reach the balanced modulator or VOX circuits.
2. CW crystal Y3 is connected to the grid of carrier oscillator V16B.
3. The balanced modulator circuit is unbalanced so it will produce an output signal (see Mode switch wafer 2F).
4. The transmitted CW signal will pass through either the Accessory CW Filter or the SSB Filter.
5. The drive to the final amplifiers is controlled by the CW section of the MIC/CW Level control, which adjusts the bias of isolation amplifier V2 and IF amplifier V3.
6. Cut off bias is applied to the grids of transmitter mixers V5A and V6, and to the grid of driver amplifier V7, through Mode switch wafer 1F and diode D904.
7. Tone oscillator V15A is turned on.

When the key is closed, the 1000 Hz tone signal is coupled to the VOX circuit, where it causes the relays to be switched to the transmit position. The relays stay in this position for a length of time that is determined by the setting of the VOX Delay control.

At the same time, the key shorts out the cut-off bias that is applied to the transmitter mixer stages and to the driver amplifier stage, allowing them to conduct and place the transmitter on the air.

The RF output signal from CW carrier oscillator V16B is coupled to the balanced modulator stage. The unbalanced condition of this stage causes the RF signal to be coupled through transformer T1 to isolation amplifier V2. From V2, the signal proceeds through the transmitter in the same manner as the LSB and USB signals.

## Switching (Figure 2-20)

Figure 2-20 shows the position and assigns an identifying number to each of the relay sections on the main schematic. The numbers will be used in the following paragraphs to explain how each section is used.

1. This section applies B+ voltage to the correct half of carrier oscillator tube V16 in the Tune and CW positions of the Mode switch.
2. This section is connected to the power plug for external use with linear amplifiers and other devices. The contacts have a rating of 3 amperes at 117 VAC or 30 VDC.
3. These contacts apply B+ voltage to the screens of V2, V7, V8, and V9 in the transmit mode, and to the screen of V4, V10 and V11 in the receive mode of operation.
4. These contacts ground out the receiver cut-off bias in the receive mode. In the transmit mode they ground out the cut-off bias that is applied through diode D301 to transmitter stages V5A, V6, and V7.

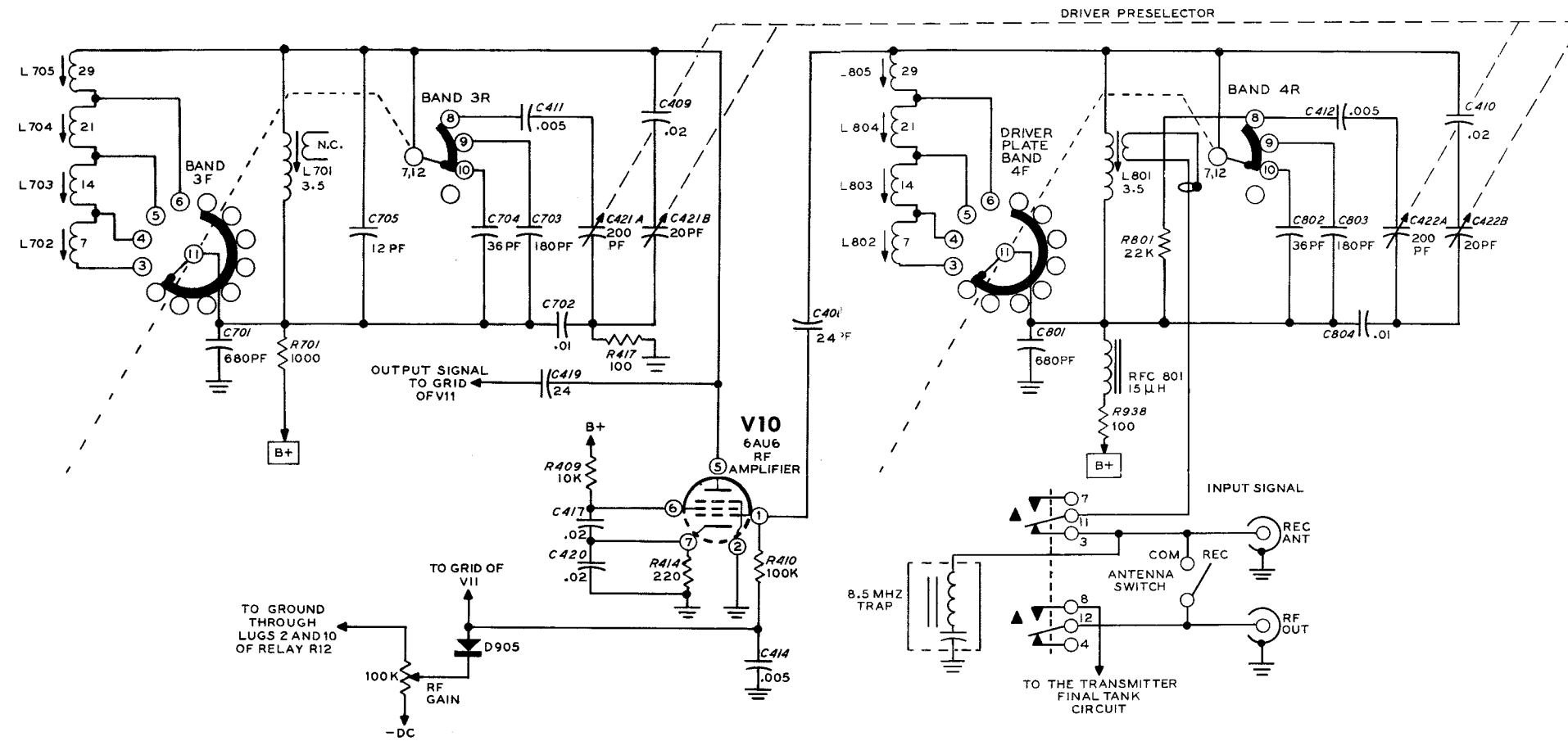

FIGURE 2-22

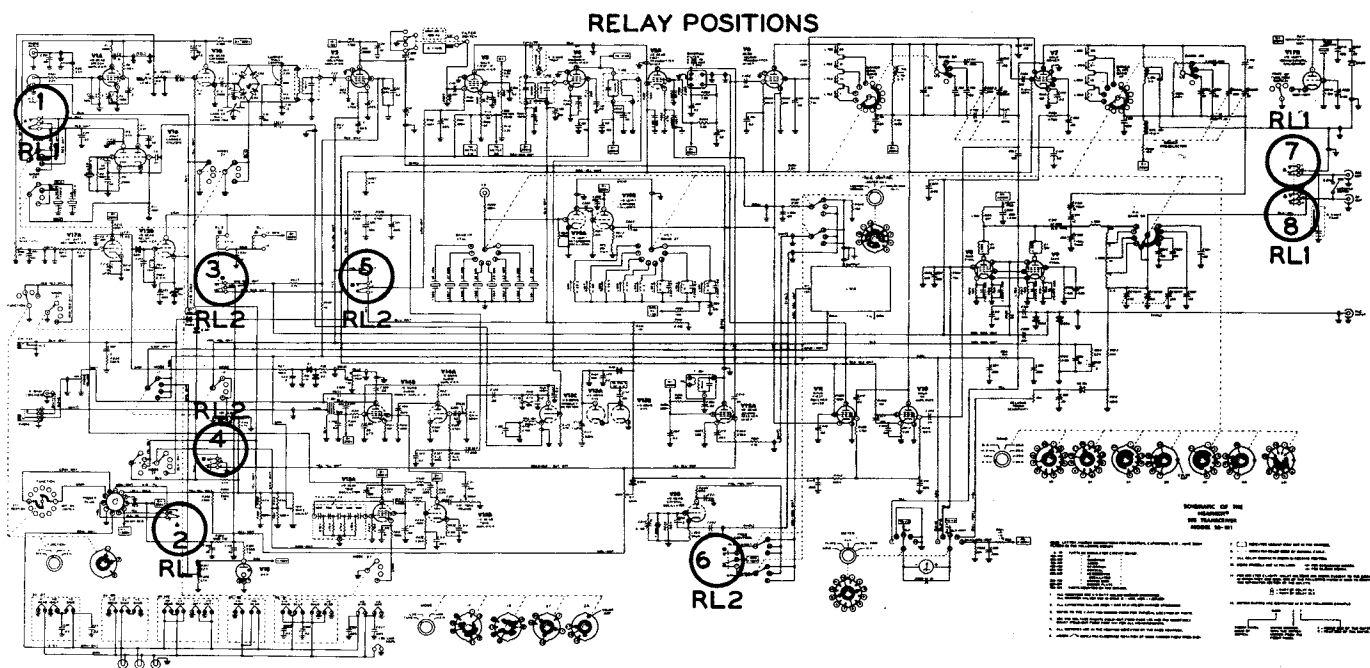

Figure 2-20

5. In the transmit mode, these contacts apply ALC voltage (or CW bias) to the grid of V3. In the receive mode they apply AVC voltage to V3.
6. This section applies +150 V B+ voltage through the Freq Control switch to either the LMO or crystal oscillator V5B.
- 7,8. These contacts switch the antenna between the receive and transmit circuits.

When the Transceiver is in the transmit mode, a large negative bias (approximately -90 volts) is applied through the RF Gain control and diode D905 to the grids of RF amplifier V10, and first receiver mixer V11. Smaller amounts of negative bias are also applied to second receiver mixer V12A, second IF amplifier V4, and audio amplifier V14A. The large bias is necessary at V10 to keep the transmitter signal at the

driver plate from causing V10 to conduct on large voltage peaks. (If this happens, spikes will appear at the peaks of the envelope on the transmitted signal.)

First audio amplifier V14B is cut off by the bias voltage to quiet the receiver audio stages when LSB or USB signals are being transmitted. A negative pulse is also applied to the grid of V14A to cut it off before the relay contacts close. This is done so the switching transients, which cause a "popping" sound, will not be heard in the speaker.

The negative pulse that is applied to V14B is formed by the sudden voltage change that occurs at the plate of relay amplifier V12B when that stage is turned on by the VOX circuit. This pulse is shaped by a network that consists of resistors R337, R338, R339, and R340 and capacitors C320, C321, C322, and C323.



BAND	RECEIVED SIGNAL FREQUENCY	HETERODYNE OSCILLATOR FREQUENCY (CRYSTAL)	SIGNAL FREQUENCY AT BANDPASS FILTER (BETWEEN 8,395 AND 8,895)	2ND RECEIVER MIXER, CRYSTAL FILTER AND IF FREQUENCIES	LMO FREQUENCY (BETWEEN 5 AND 5.5)
3.5 to 4	3.895	12.395	8.5	3.395	5.105
7 to 7.5	7.2	15.895	8.695	3.395	5.3
14 to 14.5	14.2	22.895	8.695	3.395	5.3
21 to 21.5	21.3	29.895	8.595	3.395	5.2
28 to 28.5	28.1	36.895	8.795	3.395	5.4
28.5 to 29	28.7	37.395	8.695	3.395	5.3
29 to 29.5	29.2	37.895	8.695	3.395	5.3
29.5 to 30	29.6	38.395	8.795	3.395	5.4
All frequencies in MHz.					

Figure 2-21

### RECEIVER CIRCUITS

NOTE: Figure 2-21 shows the various frequencies that will be found throughout the Transceiver on the different bands. A received signal (lower sideband) frequency of 3.895 MHz, shown on the first line of the chart, will be used when tracing through the receiver circuits. The other associated frequencies used in this Description are also shown on the first line.

#### RF Amplifier (Figure 2-22, fold-out from Page 138)

The 3.895 MHz input signal from the antenna is coupled through lugs 3 and 11 of the antenna relay (RL1) to the link winding of coil L801. The secondary of L801, part of the Driver Preselector capacitor, and the other components in the driver plate tank circuit, are also used as the input tuned circuit for RF amplifier V10. From L801, the signal is coupled through capacitor C408 to the grid of V10.

The received signal is amplified in V10, and then coupled through capacitor C419 to first receiver mixer V11. The plate tuned circuit of V10 consists of coil L701, part of the Driver Preselector capacitor, and the other components of the second transmitter mixer plate tank circuit.

The gain of RF amplifier V10 and first receiver mixer V11 are controlled by the AVC voltage, and an adjustable negative bias that is coupled to their grids from the RF Gain control.

#### First and Second Receiver Mixers (Figure 2-23)

The amplified 3.895 MHz signal from RF amplifier V10 is coupled through capacitor C419 to the grid of V11, the first receiver mixer. At the same time, a crystal controlled 12,395 MHz signal is coupled to the cathode of V11 from V19B, the heterodyne oscillator cathode follower. These two signals are then mixed together in V11 and coupled with the sum and difference frequencies to the bandpass filter.

The bandpass filter, which passes only the frequencies between 8,395 and 8,895 MHz, allows the 8.5 MHz difference frequency to pass on from V11 to the grid of second mixer tube V12A.

A 5.105 MHz signal is coupled from either the LMO or crystal oscillator V5B, through the Freq Control switch to the cathode of V12A. The 8.5 MHz signal at the grid and the 5.105 MHz signal at the cathode are then mixed together in tube V12A and the 3.395 MHz difference frequency is coupled through crystal filter FL1 to the IF amplifiers.

The Filter switch selects either crystal filter FL1 for SSB use or FL2 for CW use. Crystal filter FL1 sets the IF bandwidth at just 2.1 KHz wide (see Figure 2-11 on Page 131). This narrow, steep sided passband permits good selectivity for SSB reception in crowded amateur bands. Crystal filter FL2 can be switched in for CW reception. FL2 sets the IF bandwidth at just 400 Hz wide. This narrow bandwidth is good for CW reception only.



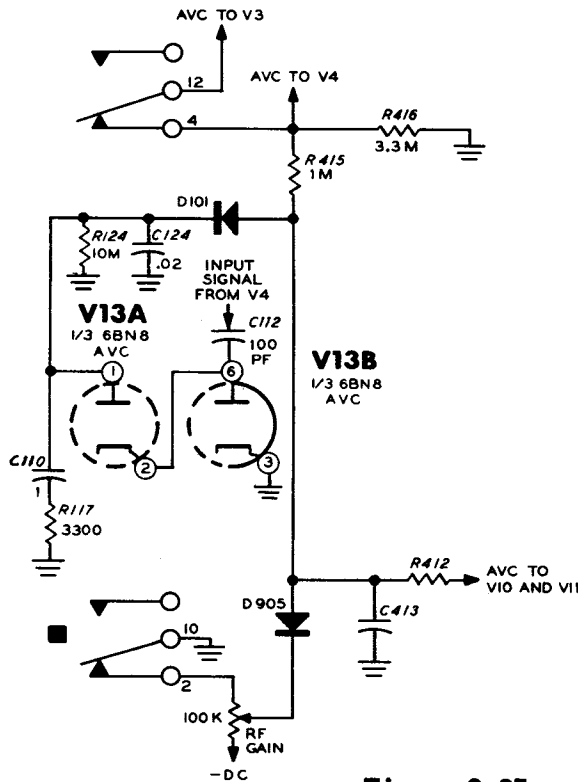

Figure 2-25

**AVC Circuit (Figure 2-25)**

The negative bias at the control grids determines the amount of amplification that will be obtained from RF amplifier V10, first receiver mixer V11, and IF amplifiers V3 and V4. The DC bias for these stages comes from the following two sources: from the -DC voltage at the arm of the RF Gain control; and from the AVC voltage. These two voltage sources are connected to diodes D101 and D905, which act as a diode gate. This diode gate permits either voltage to control the gain (of V10, V11, etc.) without interacting with each other.

From this point, the bias voltage is coupled through resistor R412 to the grids of V10 and V11, and through resistor R415 to the grids of V3 and V4. Voltage divider resistors R415 and R416 cause only one half of the total bias voltage to be coupled to the grids of IF amplifiers V3 and V4.

AVC voltage is obtained by coupling part of the IF signal through capacitor C112 to AVC diodes V13A and V13B. These diodes produce a negative DC voltage at pin 1 of V13A that is proportional to the signal strength. This negative voltage is developed across resistors R124 and R117, and capacitors C110 and C124. Capacitor C124 charges quickly to the peak voltage so the AVC will respond quickly to keep large signals from being distorted in V3, V4, V10, and V11. Capacitor C110 charges more slowly, and causes the AVC voltage to be proportional to the average signal level of the received signal. This produces a fast-attack, slow-release AVC characteristic.

An incoming signal that produces a negative AVC voltage that is significantly higher than the bias voltage from the RF Gain control causes the gain of V10, V11, V3, and V4 to be reduced. This keeps the output of the RF and IF amplifier stages at a nearly constant level despite wide amplitude changes in the received signal.

**Product Detector (Figure 2-26)**

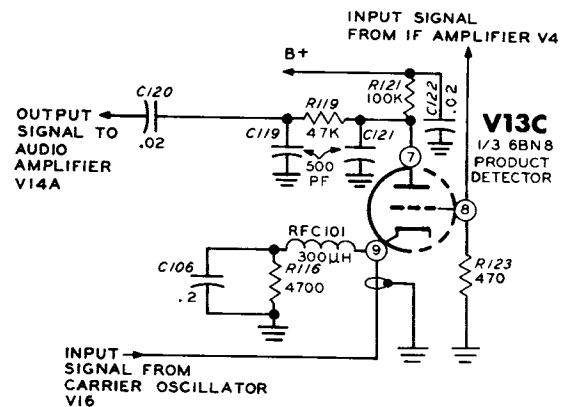

Figure 2-26

The 3.395 MHz signal from IF amplifier V4 is coupled to the grid of product detector tube V13C. At the same time, the signal from carrier oscillator V16 is fed to the cathode of V13C (3.3936 MHz for the lower sideband, or 3.3964 MHz for the upper sideband). These two signals are then mixed together in V13C, resulting in an audio output signal which is the

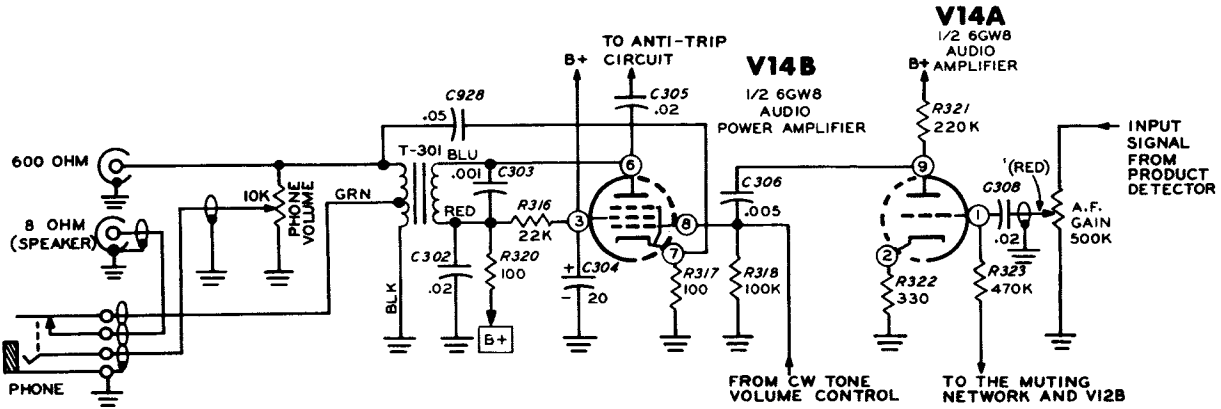

Figure 2-27

difference frequency between these two signals. Capacitors C119 and C121, and resistor R119 are connected in a filter network that bypasses any RF signal coming from V13C to ground, but permits the audio signal to pass through to audio amplifier V14A.

**Audio And Power Amplifier (Figure 2-27)**

The signal from the product detector is applied to the AF Gain control to determine the amount of signal that will be coupled through capacitor C308 to the grid of audio amplifier V14A. The audio signal is amplified in V14A and then coupled to power amplifier V14B. Tube V14B amplifies the signal further and supplies the audio power through output transformer T301 to the output connectors. Capacitor C928 couples a portion of the output back to the cathode of V14B as negative feedback for less distortion.

Three outputs are provided by the secondary of transformer T301: a headphone output, a 600 Ω output, and an 8 Ω speaker output. Audio power to the 8 Ω speaker jack is rated at 2 watts maximum.

An audio signal is also supplied to the anti-trip network from the plate of V14B.

**CRYSTAL CALIBRATOR (Figure 2-28)**

Crystal calibrator stage V17B is connected as a Pierce crystal oscillator. When the Function switch is placed in the Calibrate position, the

cathode of V17B is grounded, and an accurate 100 kHz signal is connected through capacitor C218 and diode CR201 to the antenna input of the receiver. The harmonics of this signal are then used for dial calibration checks.

Calibrate Crystal capacitor C220 may be adjusted to set the crystal calibrator to exactly 100 kHz using some standard such as WWV.

The Calibrate position of the Function switch also connects the grid of VOX amplifier V17A to ground to avoid accidental energizing of the transmitter when using the crystal calibrator.

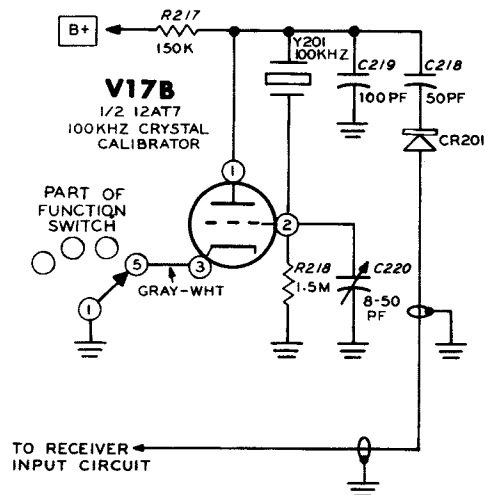

Figure 2-28

## METERING CIRCUITS (Figure 2-29)

For the transmitting mode of operation, there are five different settings of the Meter switch: final Grid current, final Plate current, ALC voltage, Relative Power output, and High Voltage. In the ALC position, in the receive mode, the meter operates as an S-Meter.

To measure the grid current for final amplifiers V8 and V9, the meter is shunted across resistor R916 in the grid circuit of these tubes. The meter will then read from 0 to 1 ma of grid current.

To measure final amplifier plate current, the meter is connected between the cathodes of the finals and ground, in parallel with the cathode resistors. Plate current can then be read on the 0 to 500 ma range of the meter.

To measure ALC voltage, the meter is connected between the cathode and screen circuits of IF amplifier V3. The meter zero control is adjusted for zero current flow through the meter with no signal input. When V3 receives a signal, the resulting current fluctuations in the cathode are indicated on the meter. Since the ALC voltage at the grid controls the gain of V3, the cathode current of V3 gives a relative indication of the ALC voltage level.

For Relative Power measurements, a small portion of the transmitter output signal is developed across resistor R912, rectified by diode CR901, and filtered by capacitor C933. The resulting DC voltage, is then indicated by the meter. The Relative Power Sensitivity control allows the operator to set his full power output indication at a convenient meter reading.

The high voltage is brought down to a measurable level by a precision multiplier resistor, R921. 0-1000 volts can be read on the 0-10 scale of the meter. Resistor R922 keeps the open circuit voltage at a safe level when the Meter switch is in other positions.

When the Transceiver is in the receive condition, and the Meter switch is at ALC, the meter indicates the relative strength of the received signal in S-units. The circuit operates just as it does when it measures ALC voltage, except that the current in V3 is now controlled by the AVC voltage at the grid of V3.

The Meter Zero control is adjusted for a zero indication on the meter with the antenna disconnected and RF Gain control at the full clockwise position. The decrease in plate current (due to a larger AVC voltage) that occurs when a signal is received by tube V3 then appears as indications on the S-Meter.

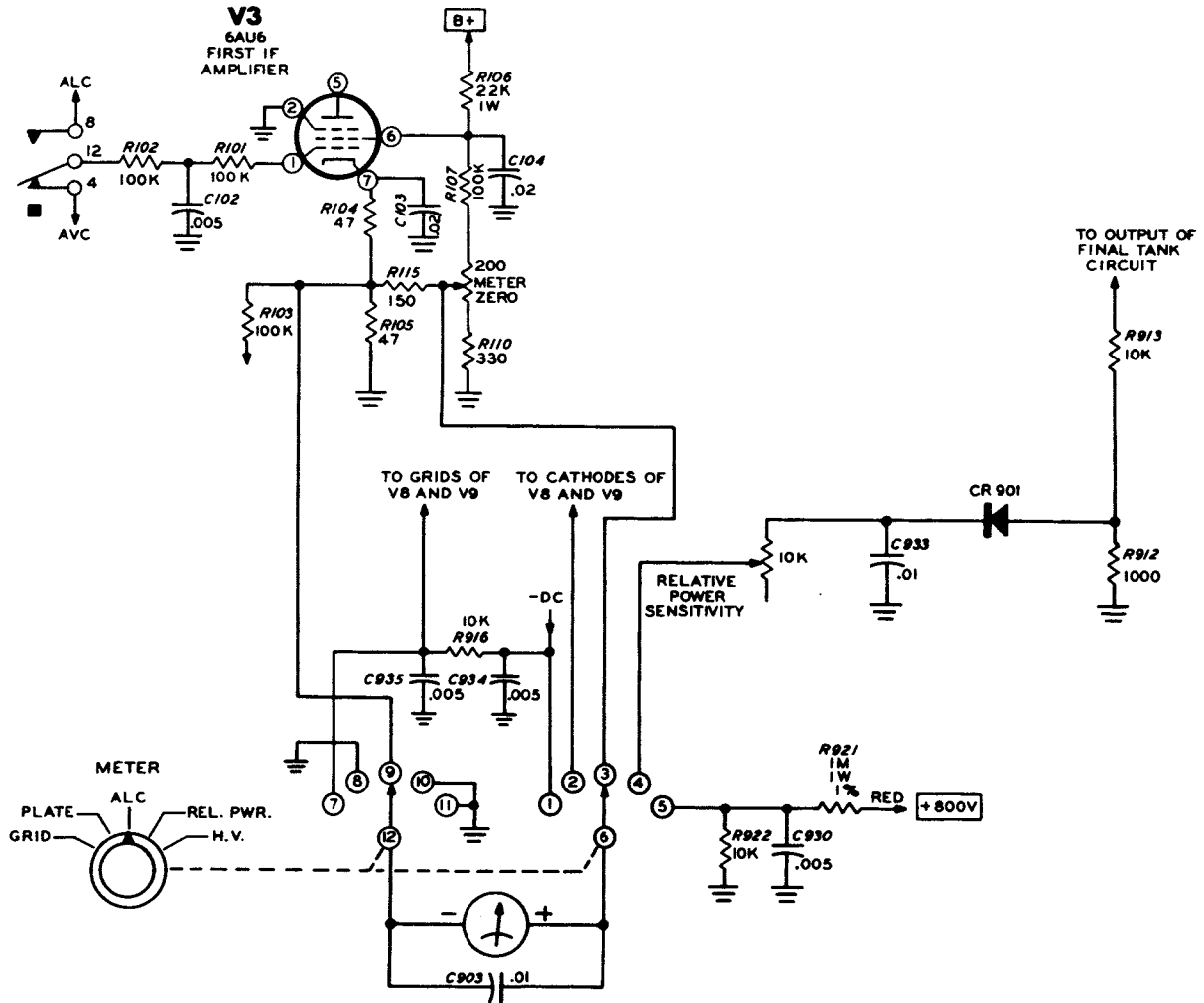
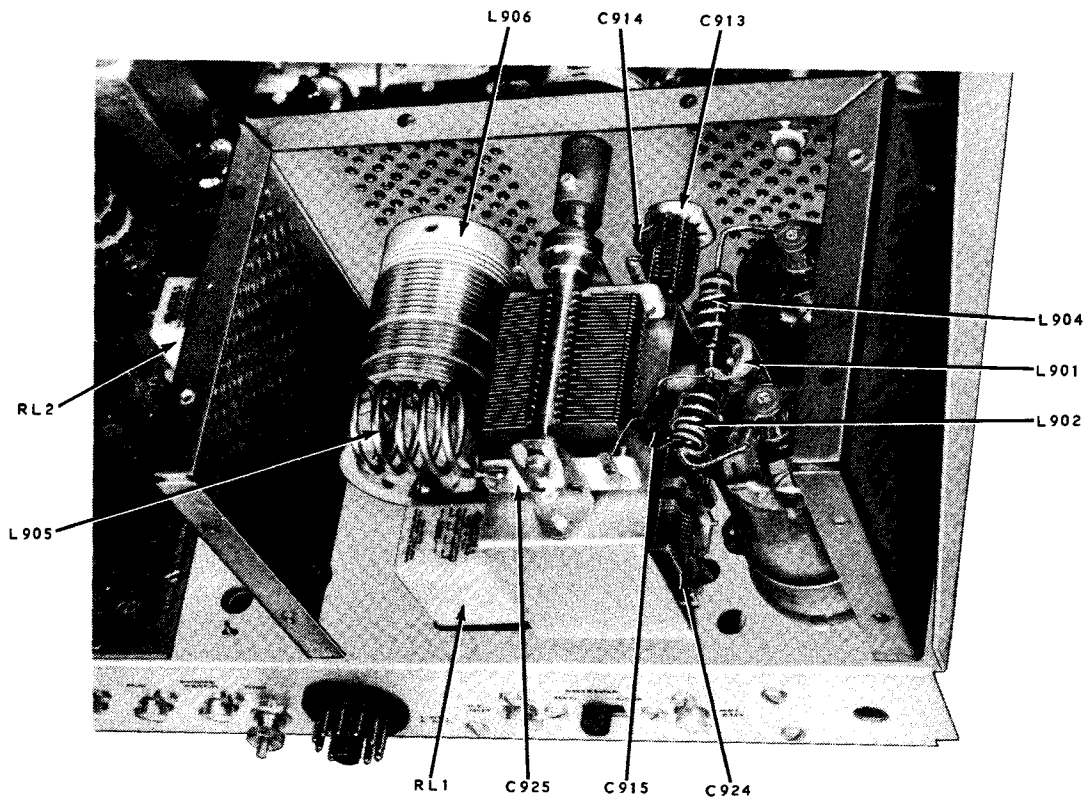
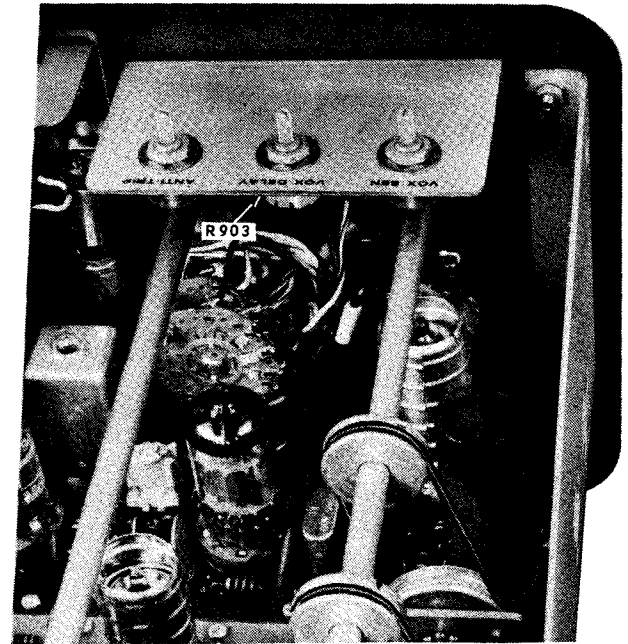
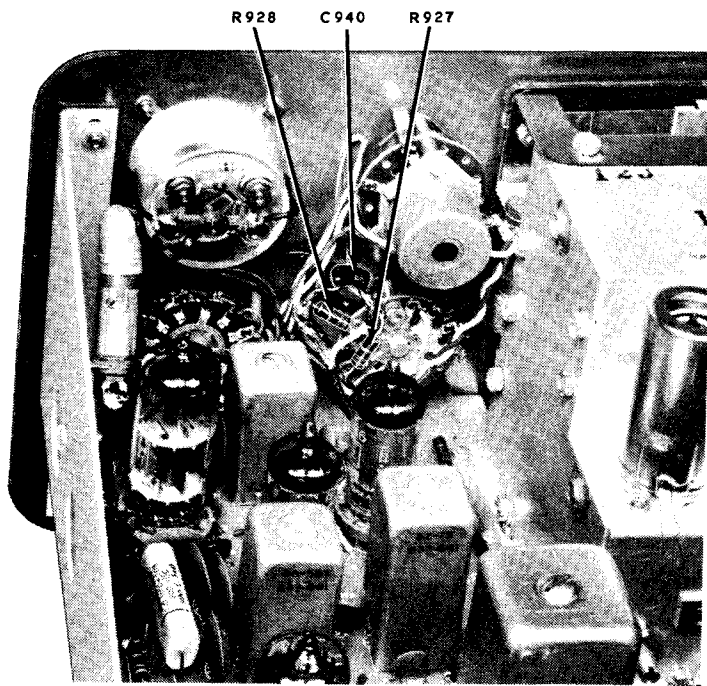
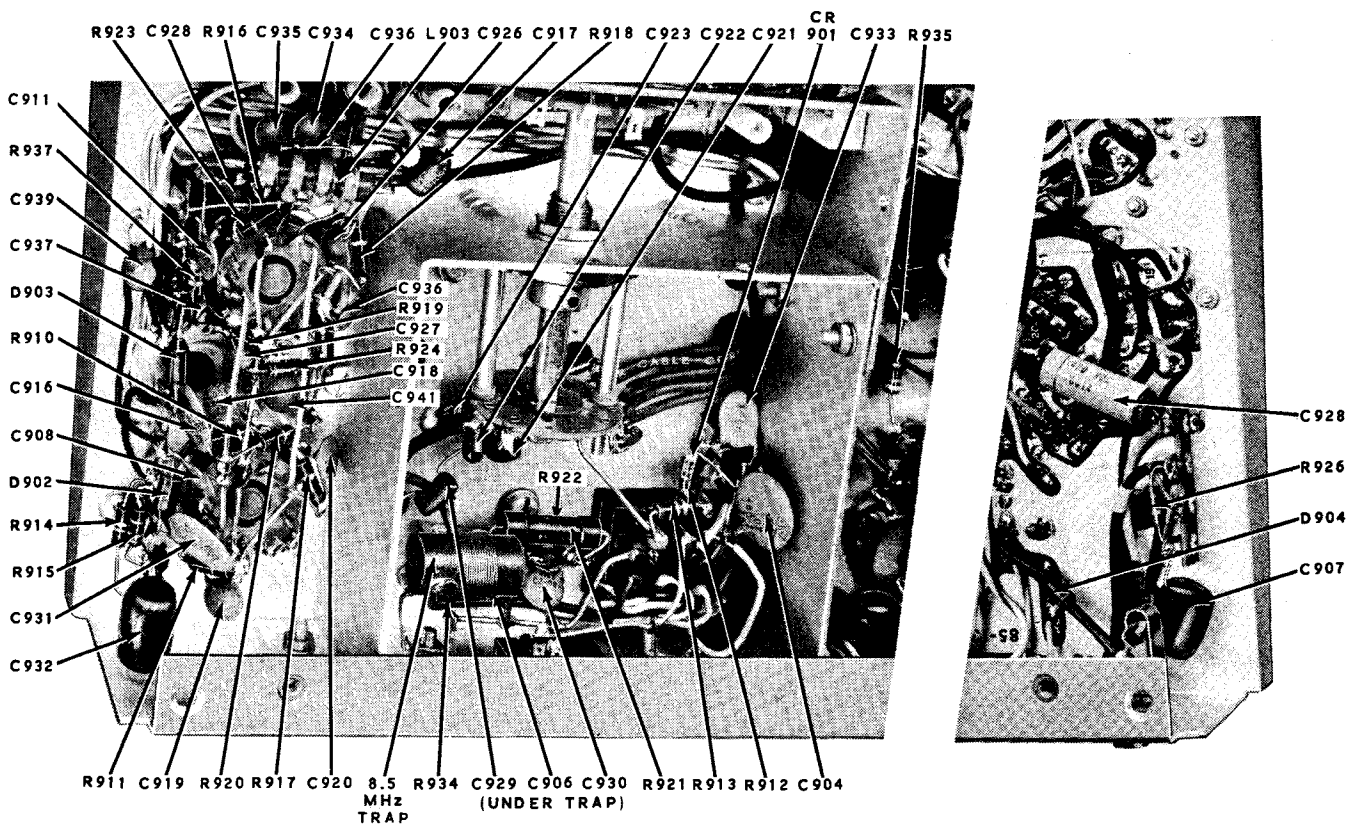
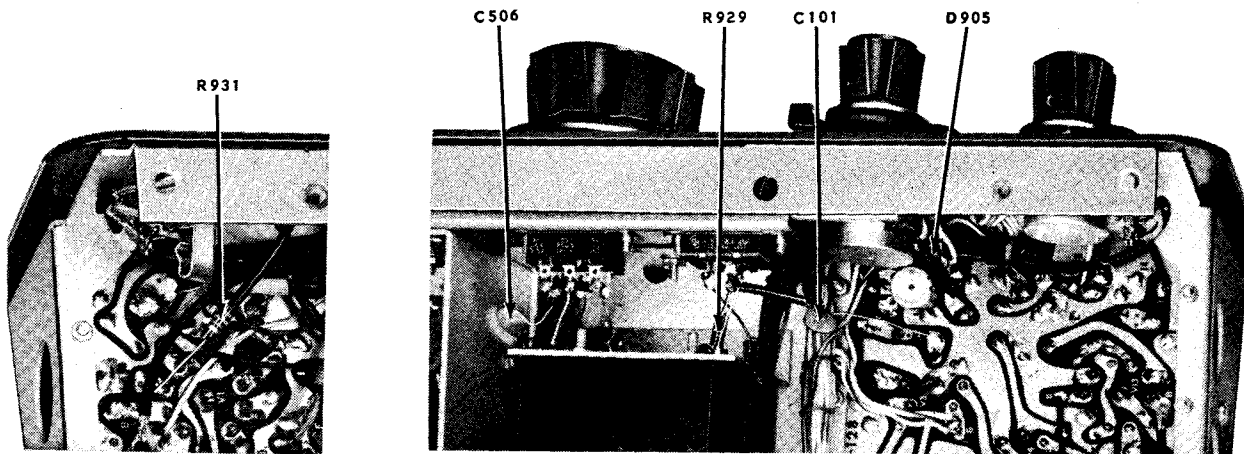

Figure 2-29

# CHASSIS PHOTOGRAPHS



TOP VIEW



**BOTTOM VIEW**



# CIRCUIT BOARD X-RAY VIEWS (VIEWED FROM FOIL SIDE)

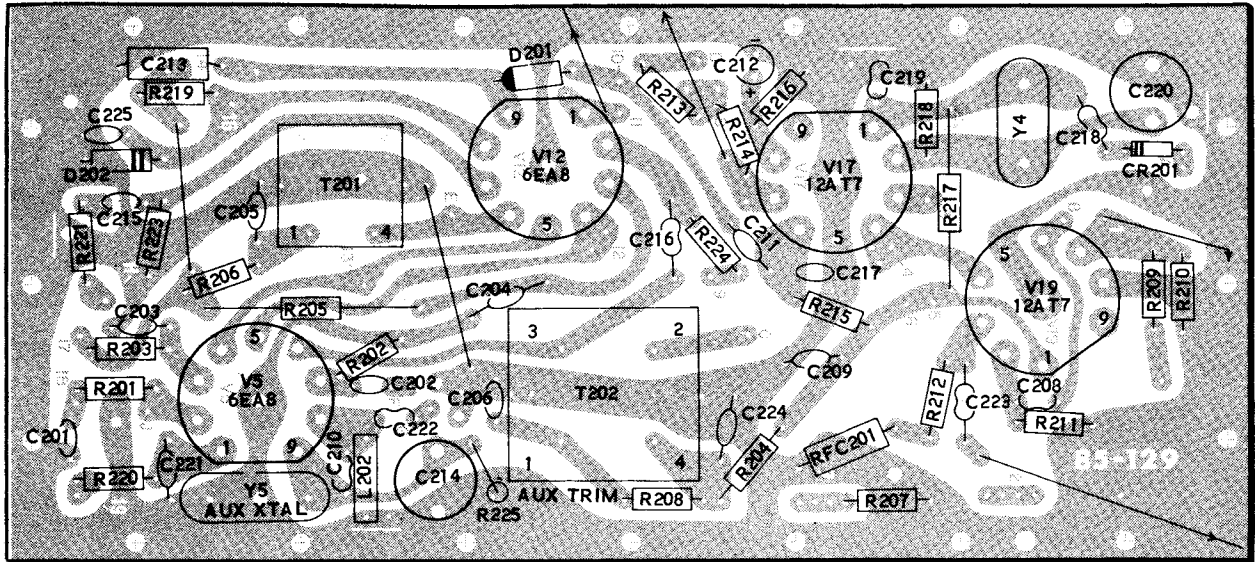

**BANDPASS CIRCUIT BOARD**  
#85-129-2

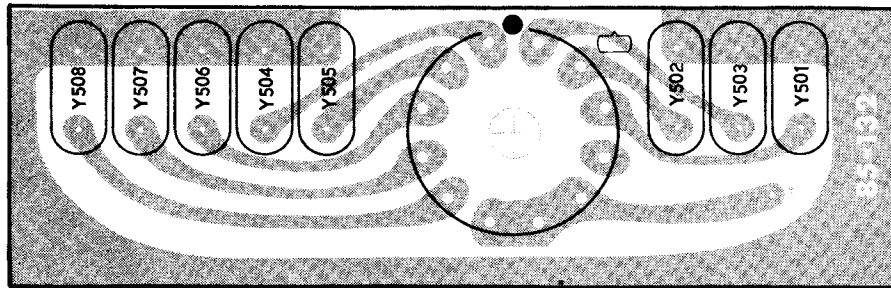

**CRYSTAL CIRCUIT BOARD**  
#85-132-1

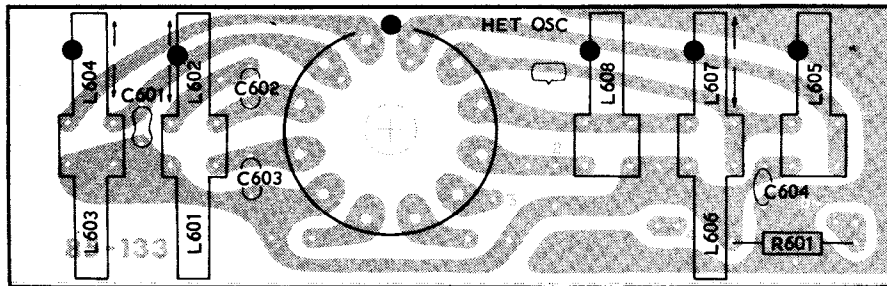

**HETERODYNE OSCILLATOR CIRCUIT BOARD**  
#85-133-1

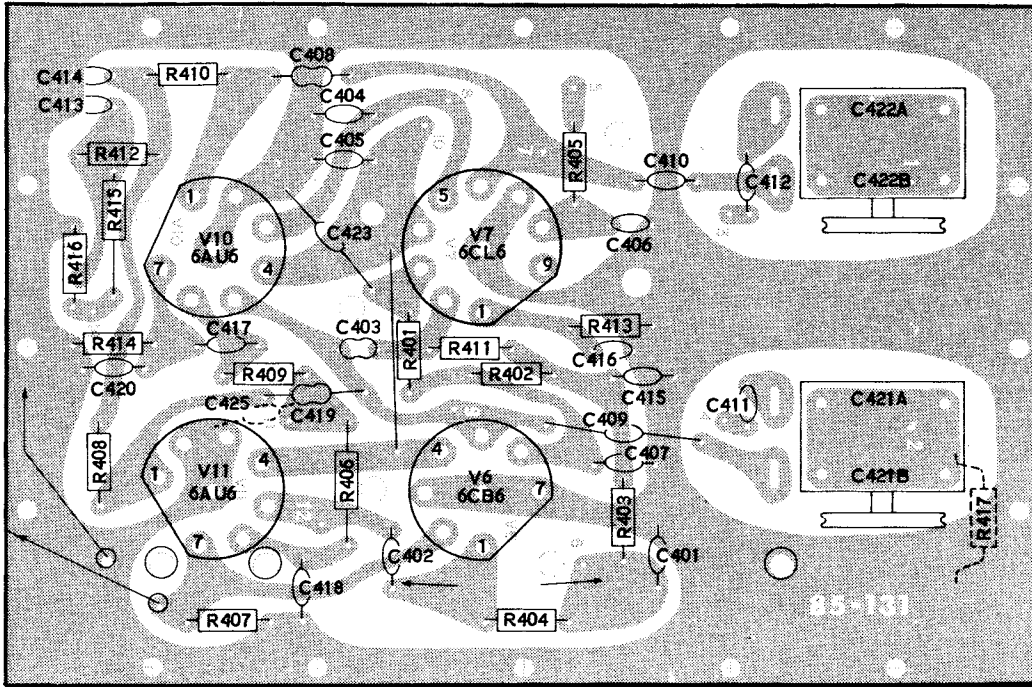

**RF-DRIVER CIRCUIT BOARD**  
#85-131-1

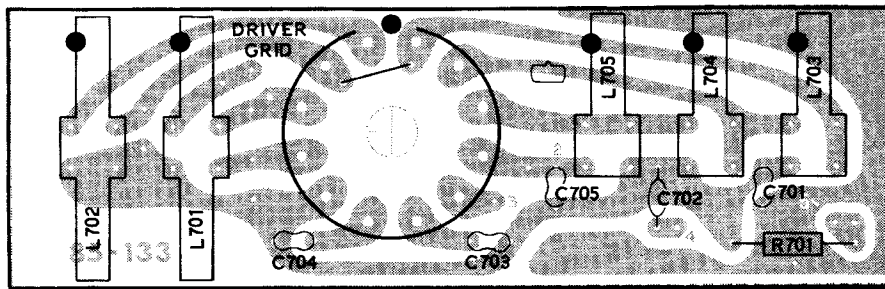

**DRIVER GRID CIRCUIT BOARD**  
#85-133-2

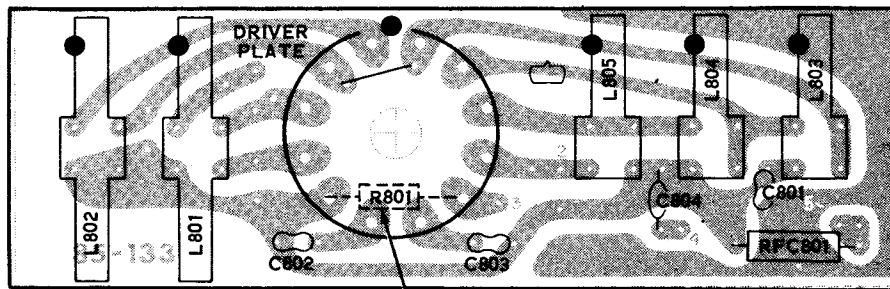

THIS RESISTOR LOCATED  
ON SWITCH WAFER.

**DRIVER PLATE CIRCUIT BOARD**  
#85-133-3

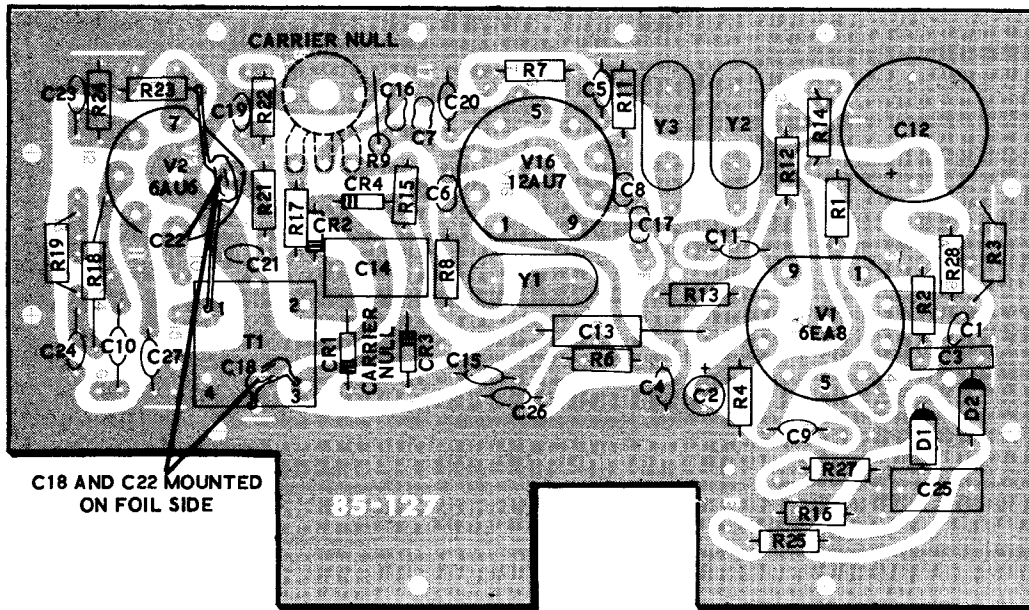

**MODULATOR CIRCUIT BOARD**  
#85-127-1

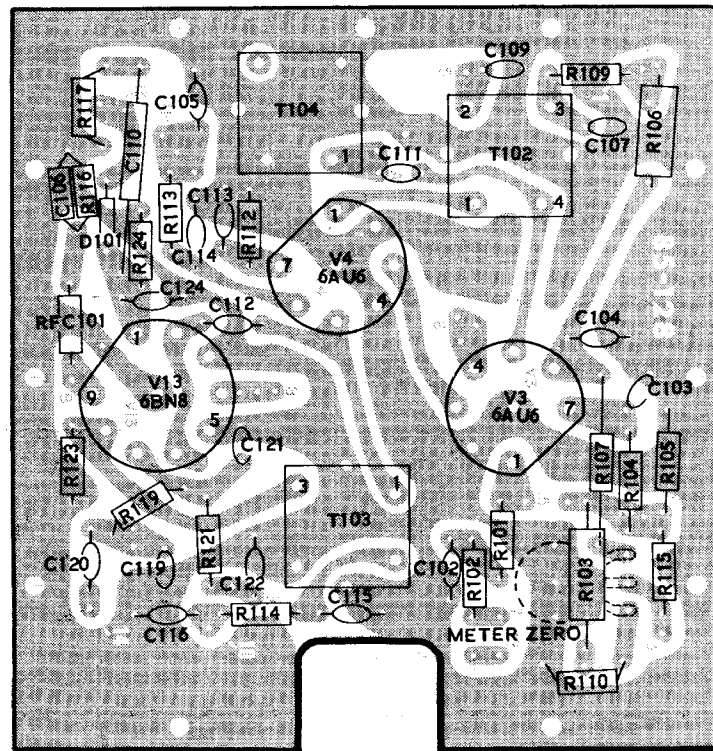

**IF CIRCUIT BOARD**  
#85-128-2

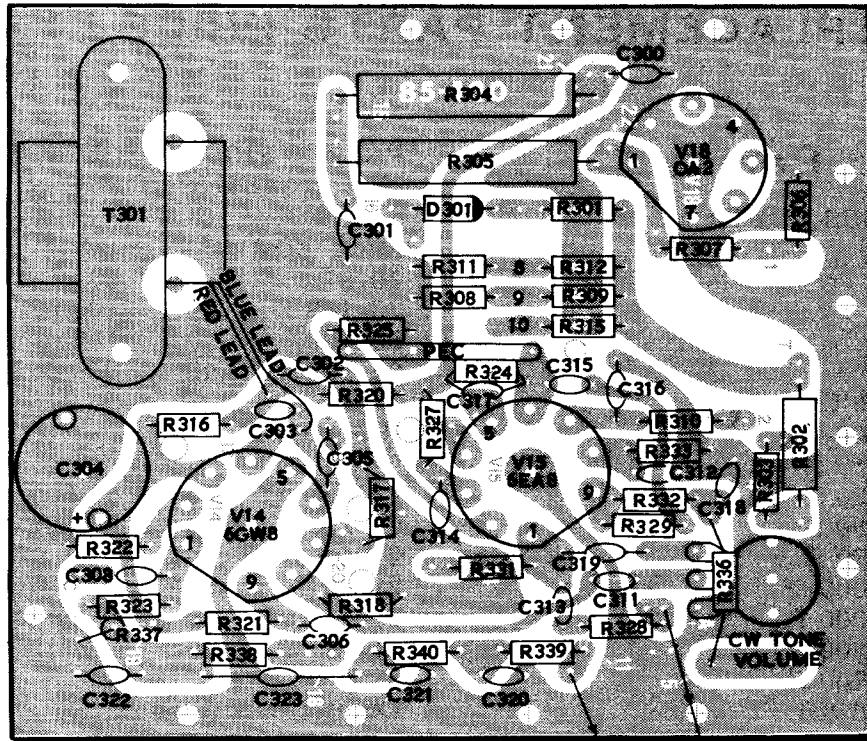

**AUDIO CIRCUIT BOARD**  
#85-130-1

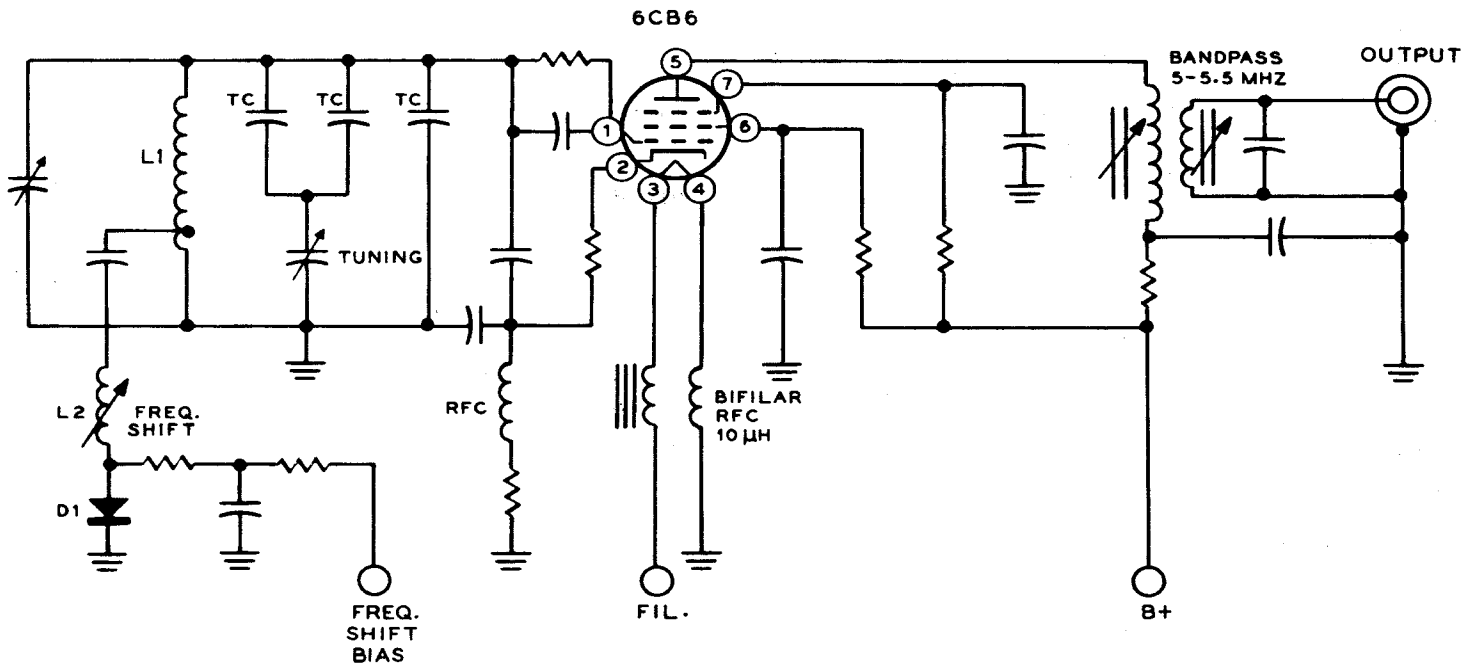

**LMO SCHEMATIC**



## REPLACEMENT PARTS PRICE LIST

### Circuit Board Parts

PART No.	PRICE Each	DESCRIPTION
----------	------------	-------------

#### RESISTORS

##### 1/2 Watt

1-83	.15	56 $\Omega$
1-3	.10	100 $\Omega$
1-111	.10	150 $\Omega$
1-45	.10	220 $\Omega$
1-4	.10	330 $\Omega$
1-6	.10	470 $\Omega$
1-9	.10	1000 $\Omega$
1-90	.10	2000 $\Omega$
1-14	.10	3300 $\Omega$
1-16	.10	4700 $\Omega$
1-20	.10	10 K $\Omega$
1-22	.10	22 K $\Omega$
1-24	.10	33 K $\Omega$
1-25	.10	47 K $\Omega$
1-26	.10	100 K $\Omega$
1-27	.10	150 K $\Omega$
1-29	.10	220 K $\Omega$
1-31	.10	330 K $\Omega$
1-33	.10	470 K $\Omega$
1-34	.10	680 K $\Omega$
1-35	.10	1 megohm
1-36	.10	1.5 megohm
1-37	.10	2.2 megohm
1-38	.10	3.3 megohm
1-40	.10	10 megohm

##### 1 Watt

1-3-1	.10	3300 $\Omega$
1-5-1	.10	22 K $\Omega$

##### 7 Watt

3-15-7	.15	1000 $\Omega$
3-16-7	.15	2500 $\Omega$

#### CAPACITORS

##### Mica

20-130	.15	12 pf
20-77	.15	24 pf
20-96	.15	36 pf

PART No.	PRICE Each	DESCRIPTION
----------	------------	-------------

##### Mica (cont'd.)

20-97	.15	50 pf
20-102	.15	100 pf
20-105	.20	180 pf
20-107	.40	680 pf

##### Disc

21-78	.10	5 pf
21-13	.10	500 pf
21-14	.10	.001 $\mu$ fd
21-27	.10	.005 $\mu$ fd
21-16	.10	.01 $\mu$ fd
21-31	.10	.02 $\mu$ fd

##### Other Capacitors

25-115	.45	10 $\mu$ fd electrolytic
25-135	.75	20 $\mu$ fd tubular electrolytic
26-94	1.85	13 pf differential
26-102	2.05	2-section variable
27-34	.25	.2 $\mu$ fd resin
27-19	1.50	1 $\mu$ fd tubular
31-36	.85	8-50 pf trimmer

#### COILS

40-484	.15	36 $\mu$ h
40-487	.20	300 $\mu$ h
40-587	1.25	6.8 MHz trap
40-686	.50	7 MHz
40-687	.50	14/21 MHz
40-693	.80	28 MHz
40-688	.50	29 MHz
40-692	.80	29.5 MHz
40-685	.65	3.5 MHz
40-689	.95	3.5/7 MHz
40-690	.65	14/21 MHz
40-691	.95	28.5/29 MHz

#### TRANSFORMERS

52-65	5.90	8.4-8.9 MHz bandpass
52-73	1.35	3.395 MHz IF
52-79	.80	3.395 MHz

PART No.	PRICE Each	DESCRIPTION
<b>DIODES</b>		
56-25	3.00	Zener, 15 V, 1 W (1N4166A)
56-26-1	.35	1N191 germanium
57-27	.60	Silicon 750 ma 500 PIV

<b>CONTROLS</b>		
10-147	.75	200 $\Omega$
10-149	.60	500 K $\Omega$

<b>SWITCHES</b>		
63-396	.90	Rotary wafer
63-397	.85	Rotary wafer

<b>CRYSTALS</b>		
404-43	5.00	100 kHz
404-205	5.00	3393.6 kHz
404-215	4.50	3395.4 kHz
404-206	5.00	3396.4 kHz
404-207	4.35	12.395 MHz
404-208	4.35	15.895 MHz
404-209	4.35	22.895 MHz
404-210	4.35	29.895 MHz
404-211	4.35	36.895 MHz
404-212	4.35	37.395 MHz
404-213	4.35	37.895 MHz
404-214	4.35	38.395 MHz

<b>CIRCUIT BOARDS</b>		
85-127-1	2.15	Modulator
85-128-2	1.55	IF
85-129-2	2.00	Bandpass
85-130-1	1.70	Audio
85-131-2	2.10	RF-driver
85-132-1	.85	Crystal
85-133-1	.85	Heterodyne oscillator
85-133-2	.85	Driver grid
85-133-3	.85	Driver plate

<b>MISCELLANEOUS</b>		
45-51	.25	15 $\mu$ h choke
84-22	.60	P.E.C. (printed electronic circuit)
250-133	.05	3-48 x 7/16" screw
252-1	.05	3-48 nut
254-7	.05	#3 lockwasher
344-50	.05/ft	Black hookup wire

PART No.	PRICE Each	DESCRIPTION
<b>Miscellaneous (cont'd.)</b>		
346-1	.05/ft	Small sleeving
434-74	.15	Crystal socket
434-129	.15	7-pin tube socket
434-130	.15	9-pin tube socket
490-5	.05	Nut starter
331-6	.10	Solder
595-840	2.00	Manual

## Chassis Parts

PART No.	PRICE Each	DESCRIPTION
----------	------------	-------------

<b>RESISTORS</b>		
<b>1/2 Watt</b>		
1-41	.10	10 $\Omega$
1-83	.15	56 $\Omega$
1-3	.10	100 $\Omega$
1-4	.10	330 $\Omega$
1-96	.10	750 $\Omega$
1-9	.10	1000 $\Omega$
1-90	.10	2000 $\Omega$
1-16	.10	4700 $\Omega$
1-20	.10	10 K $\Omega$
1-22	.10	22 K $\Omega$
1-25	.10	47 K $\Omega$
1-35	.10	1 megohm
1-37	.10	2.2 megohm
1-38	.10	3.3 megohm

<b>Precision (1/2 Watt)</b>		
2-76	.25	500 K $\Omega$ 1%

<b>CAPACITORS</b>		
<b>Mica</b>		
20-130	.15	12 pf
20-77	.15	24 pf
20-102	.15	100 pf
20-105	.20	180 pf

<b>Disc</b>		
21-14	.10	.001 $\mu$ fd
21-27	.10	.005 $\mu$ fd
21-44	.15	.005 $\mu$ fd 1.6 KV
21-16	.10	.01 $\mu$ fd
21-31	.10	.02 $\mu$ fd



PART No.	PRICE Each	DESCRIPTION	PART No.	PRICE Each	DESCRIPTION
<b>Other Capacitors</b>			<b>TERMINAL STRIPS</b>		
26-24	2.20	20 pf variable	431-62	.10	3-lug miniature
26-77	5.00	250 pf variable	431-12	.10	4-lug
26-109	1.95	2-section variable	431-11	.10	5-lug
26-92	2.85	3-section variable	431-45	.10	6-lug
23-59	.20	.05 $\mu$ fd tubular	<b>CONNECTORS-JACKS-PLUGS</b>		
27-34	.25	.2 $\mu$ fd resin	432-38	1.10	Male connector
<b>COILS</b>			432-39	1.10	Female connector
40-546	.60	8.5 MHz trap coil	436-4	.35	3-lug jack
40-549	.45	10-meter coil	436-21	.95	4-lug jack
40-548	4.00	Final tank coil	438-4	.10	Phono plug
<b>CHOKES</b>			438-29	.40	11-pin plug
45-41	.95	425 $\mu$ h	<b>SOCKETS</b>		
45-30	.40	.5 mh	434-39	.15	Octal
45-53	.40	Parasitic	434-42	.10	Phono
<b>DIODES</b>			434-44	.15	Pilot lamp
56-26-1	.35	1N191 germanium	434-118	.40	11-pin
57-27	.60	Silicon 750 ma 500 PIV	434-143	1.00	Relay
<b>CONTROLS</b>			<b>SHIELDS</b>		
10-57	.35	10 K $\Omega$ tab mount	206-77	.15	Small tube, 1-3/4" long
10-208	1.95	100 K $\Omega$ with switch lever	206-68	.10	Large tube, 1-3/4" long
10-68	.65	500 K $\Omega$	206-206	.15	Large tube, 2" long
10-153	.75	1 megohm miniature	206-86	.10	Pilot lamp
10-154	.75	10 megohm miniature	<b>TUBES-PILOT LAMP</b>		
12-48	1.50	10 K $\Omega$ and 1 megohm dual	411-59	1.35	OA2 tube
<b>SWITCHES</b>			411-11	1.00	6AU6 tube
60-2	.25	DPDT slide	411-128	1.60	6BN8 tube
60-4	.20	SPDT slide	411-67	1.05	6CB6 tube
60-1	.15	SPST slide	411-63	1.90	6CL6 tube
63-395	1.10	Rotary wafer (blue dot)	411-124	1.50	6EA8 tube
63-400	1.80	3-position single wafer	411-173	1.55	6GW8 tube
63-94	1.10	5-position single wafer	411-24	1.45	12AT7 tube
63-349	2.40	4-position single wafer with snap switch	411-25	1.20	12AU7 tube
63-399	2.10	4-position double wafer	411-75	4.35	6146 tube
<b>INSULATORS</b>			412-14	.15	#44 pilot lamp
71-4	.45	Standoff	<b>HARNESSES-WIRE-SLEEVING</b>		
73-3	.10	1/2" rubber grommet	134-121	5.00	Wire harness
73-46	.10	5/16" plastic grommet	134-122	5.00	Coaxial cable harness
			340-3	.05/ft	Small bare wire



PART No.	PRICE Each	DESCRIPTION	PART No.	PRICE Each	DESCRIPTION
<b>Harnesses-Wire-Sleeving (cont'd.)</b>			<b>METAL PARTS</b>		
340-2	.05/ft	Large bare wire	90-341	20.80	Cabinet
346-2	.05/ft	Large sleeving	100-554	2.00	RF cage
343-7	.05/ft	Coaxial cable (RG-174/U)	consisting of the following:		
344-51	.05/ft	Brown hookup wire			RF cage rear plate
344-59	.05/ft	White hookup wire			RF cage top plate
344-21	.05/ft	Large red hookup wire			RF cage
<b>SHAFTS-BUSHINGS-SHAFT COUPLING</b>			204-573	.25	Capacitor bracket
453-146	1.00	8-1/4" long tubular shaft	204-588-1	.25	Control bracket
453-17	.15	9" long shaft	200-479-1	5.00	Chassis
453-125	.25	9-3/8" long shaft	203-358-2	5.00	Front panel
453-147	.65	11-1/4" long shaft	204-560	.25	Support rail
455-11	.10	Split bushing	204-677	.10	Comb bracket
455-15	.10	1/4" shaft collar	206-281	.55	Final shield
455-10	.10	3/8" long bushing	206-282	.50	Switch shield
455-18	.15	9/16" long bushing	206-280	.70	Center shield
455-44	.15	Nylon bushing	204-737	.15	Crystal filter bracket
456-4	.70	Shaft coupling	204-738	.15	Switch bracket
<b>KNOBS-KNOB INSERT</b>			205-493-1	.55	Coil cover
462-175	.15	7/16" diameter aluminum	266-97	.10	Slide switch actuator
462-191	.70	1-1/8" diameter	<b>TOOLS</b>		
462-193	1.05	2-1/2" diameter	490-1	.10	Alignment
462-218	.25	Lever	490-19	.30	Open-end wrench
455-52	.10	Knob insert	490-23	.10	#4 allen wrench
<b>DIAL PARTS</b>			490-85	.15	#8 allen wrench
268-7	.25	Rubber belt	<b>HARDWARE</b>		
446-40	.70	Dial escutcheon	<b>#3 Hardware</b>		
466-6	.10	3/4" diameter pulley	250-172	.05	3-48 x 3/8" screw
100-19	.20	Dial pulley with 1/4" hole	250-251	.20	3-48 x 3/8" flat head screw
100-458	.25	Dial pulley with 9/32" hole	252-1	.05	3-48 nut
<b>#100-450 Packaged Dial Drive Assembly, consisting of the following:</b>			254-7	.05	#3 lockwasher
204-553	.55	Dial mounting bracket	258-5	.10	#3 spring clip
100-443	1.00	Dial pointer assembly	<b>#6 Hardware</b>		
464-30-1	.25	Plastic dial window	250-56	.05	6-32 x 1/4" screw
100-447	.50	Dial pointer drive arm	250-89	.05	6-32 x 3/8" screw
250-63	.05	3-48 x 1/8" screw	250-276	.05	6-32 x 3/8" flat head screw
266-74	.10	Nylon spiral follower	250-218	.05	6-32 x 3/8" phillips head screw
100-445	.45	Zero set drive pulley (small)	250-284	.05	#6 x 1/2" sheet metal screw
100-449	2.50	Circular dial	250-26	.05	6-32 x 5/8" screw
100-444	1.65	Dial drive pulley (large)	250-40	.05	6-32 x 1-1/2" screw
455-42	.90	Drive shaft bushing package	252-3	.05	6-32 nut
			253-1	.05	#6 fiber flat washer



PART No.	PRICE Each	DESCRIPTION	PART No.	PRICE Each	DESCRIPTION
<b>#6 Hardware (cont'd.)</b>			<b>Other Hardware (cont'd.)</b>		
253-2	.05	#6 fiber shoulder washer	260-39	.05	Anode clip (may vary in appearance)
253-60	.05	#6 flat washer	435-1	.10	11-pin plug retaining ring
254-1	.05	#6 lockwasher	435-10	.10	Relay socket retaining ring
255-79	.10	Threaded shoulder spacer			
259-6	.05	Small #6 solder lug			
259-1	.05	Large #6 solder lug			
<b>#8 Hardware</b>			<b>MISCELLANEOUS</b>		
250-93	.05	#8 x 1/4" setscrew	51-123	2.05	Output transformer
250-260	.05	8-32 x 1/4" oval head screw	69-35	5.80	4PDT relay
250-72	.05	8-32 x 3/4" screw	74-6	.25	Masking tape
252-4	.05	8-32 nut	110-40	72.70	LMO (linear master oscillator)
252-28	.10	8-32 knurled nut	255-59	.15	Foot spacer
253-45	.05	#8 flat washer	261-9	.05	Rubber foot
254-2	.05	#8 lockwasher	266-85	.40	Rotary switch detent
259-2	.05	#8 solder lug	390-147	.10	High voltage label
<b>1/4" Control Hardware</b>			391-49	.30	SB-101 nameplate
252-39	.05	1/4-32 nut	404-283	37.00	2.1 kHz crystal filter
253-36	.05	1/4" dished washer	407-101	8.30	Meter
253-39	.05	1/4" flat washer	440-1	.20	11-pin socket cap
253-49	.10	1/4" nylon flat washer	352-13	.15	Silicone grease
75-18	.10	1/4" nylon shoulder washer	263-7	.05	Felt pad
253-62	.05	1/4" fiber flat washer			
259-12	.05	1/4" solder lug			
<b>3/8" Control Hardware</b>			The above prices apply only on purchases from the Heath Company where shipment is to a U.S.A. destination. Selling prices elsewhere in U.S.A. may be slightly higher to offset transportation and local taxes. Outside the U.S.A. parts and service are available from your local Heathkit source and will reflect additional transportation, taxes, duties and rates of exchange.		
252-7	.05	3/8-32 nut			
253-10	.05	3/8" flat washer			
254-5	.05	3/8" lockwasher			
259-10	.05	3/8" solder lug			
<b>Other Hardware</b>					
252-15	.05	4-40 nut			
254-9	.05	#4 lockwasher			
250-156	.10	4-40 x 1/8" setscrew			
207-22	.10	Cable clamp			