

PRICE \$2.00

HEATH COMPANY BENTON HARBOR, MICHIGAN

HEATHKIT[®] ASSEMBLY MANUAL

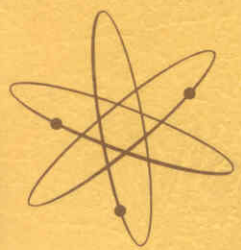

T U B E T E S T E R

MODEL TT-1

RESISTOR AND CAPACITOR COLOR CODES

RESISTORS

The colored bands around the body of a color coded resistor represent its value in ohms. These colored bands are grouped toward one end of the resistor body. Starting with this end of the resistor, the first band represents the first digit of the resistance value; the second band represents the second digit; the third band represents the number by which the first two digits are multiplied. A fourth band of gold or silver represents a tolerance of $\pm 5\%$ or $\pm 10\%$ respectively. The absence of a fourth band indicates a tolerance of $\pm 20\%$.

The physical size of a composition resistor is related to its wattage rating. Size increases progressively as the wattage rating is increased. The diameters of 1/2 watt, 1 watt and 2 watt resistors are approximately 1/8", 1/4" and 5/16", respectively.

The color code chart and examples which follow provide the information required to identify color coded resistors.

CODE			
COLOR	1ST DIGIT	2ND DIGIT	MULTIPLIER
BLACK	0	0	1
BROWN	1	1	10
RED	2	2	100
ORANGE	3	3	1,000
YELLOW	4	4	10,000
GREEN	5	5	100,000
BLUE	6	6	1,000,000
VIOLET	7	7	10,000,000
GRAY	8	8	100,000,000
WHITE	9	9	1,000,000,000
GOLD	-	-	.1
SILVER	-	-	.01

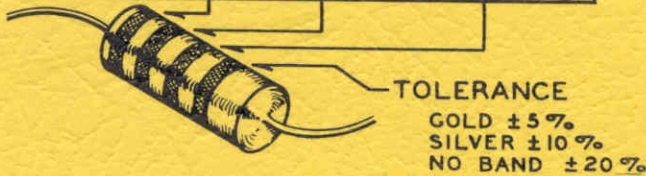

EXAMPLES

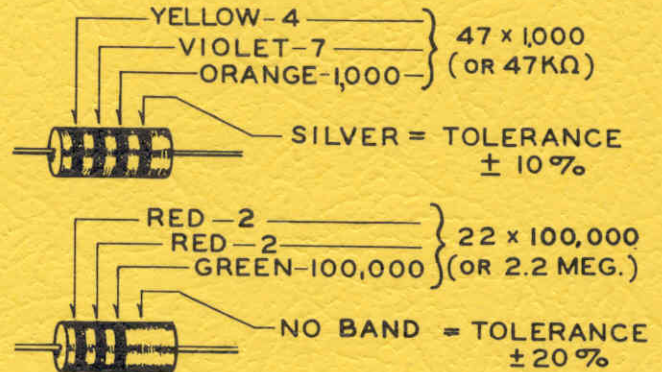

CAPACITORS

Generally, only mica and tubular ceramic capacitors, used in modern equipment, are color coded. The color codes differ somewhat among capacitor manufacturers, however the codes

shown below apply to practically all of the mica and tubular ceramic capacitors that are in common use. These codes comply with EIA (Electronics Industries Association) Standards.

MICA

CODE				
COLOR	1ST DIGIT	2ND DIGIT	MULTIPLIER	TOLER. %
BLACK	0	0	1	± 20
BROWN	1	1	10	± 20
RED	2	2	100	± 2
ORANGE	3	3	1,000	± 3
YELLOW	4	4	10,000	—
GREEN	5	5	—	± 5
BLUE	6	6	—	—
VIOLET	7	7	—	—
GRAY	8	8	—	—
WHITE	9	9	—	—
GOLD	-	-	.1	—
SILVER	-	-	.01	± 10

EXAMPLE

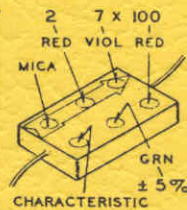

$2,700\mu\text{f} \pm 5\%$
OR .0027 μf

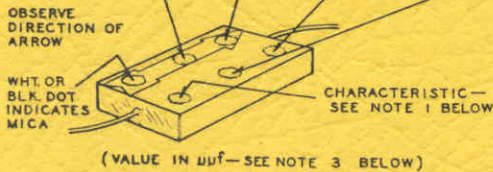

TUBULAR CERAMIC

Place the group of rings or dots to the left and read from left to right.

CODE				
COLOR	1ST DIGIT	2ND DIGIT	MULTIPLIER	TOLER. %
BLACK	0	0	1	± 20 OR ± 20
BROWN	1	1	10	± 0.1 ± 1
RED	2	2	100	± 2
ORANGE	3	3	1,000	± 2.5
YELLOW	4	4	10,000	—
GREEN	5	5	—	± 0.5 ± 5
BLUE	6	6	—	—
VIOLET	7	7	—	—
GRAY	8	8	—	± 0.25
WHITE	9	9	—	± 1.0 ± 10

EXAMPLE

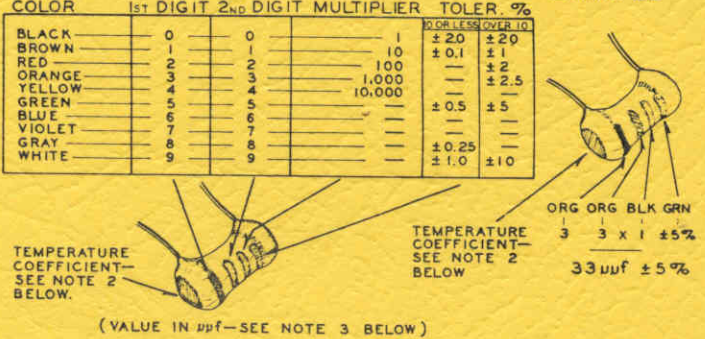

NOTES:

1. The characteristic of a mica capacitor is the temperature coefficient, drift capacitance and insulation resistance. This information is not usually needed to identify a capacitor but, if desired, it can be obtained by referring to EIA Standard, RS-153 (a Standard of Electronic Industries Association.)

2. The temperature coefficient of a capacitor is the predictable change in capacitance with temperature change and is

expressed in parts per million per degree centigrade. Refer to EIA Standard, RS-198 (a Standard of Electronic Industries Association.)

3. The farad is the basic unit of capacitance, however capacitor values are generally expressed in terms of μfd (microfarad, .000001 farad) and $\mu\mu\text{f}$ (micro-micro-farad, .000001 μfd); therefore, 1,000 $\mu\mu\text{f} = .001 \mu\text{fd}$, 1,000,000 $\mu\mu\text{f} = 1\mu\text{fd}$.

USING A PLASTIC NUT STARTER

A plastic nut starter offers a convenient method of starting the most used sizes: 3/16" and 1/4" (3-48 and 6-32). When the correct end is pushed down over a nut, the pliable tool conforms to the shape of the nut and the nut is gently held while it is being picked up and started on the screw. The tool should only be used to start the nut.

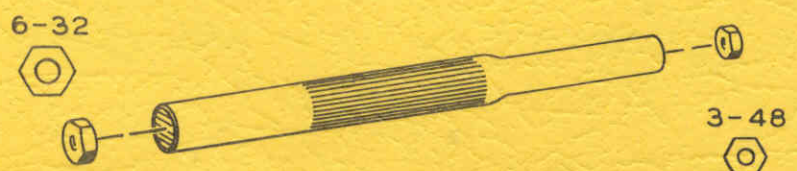

ASSEMBLY OF THE HEATHKIT G_m TUBE TESTER MODEL TT-1

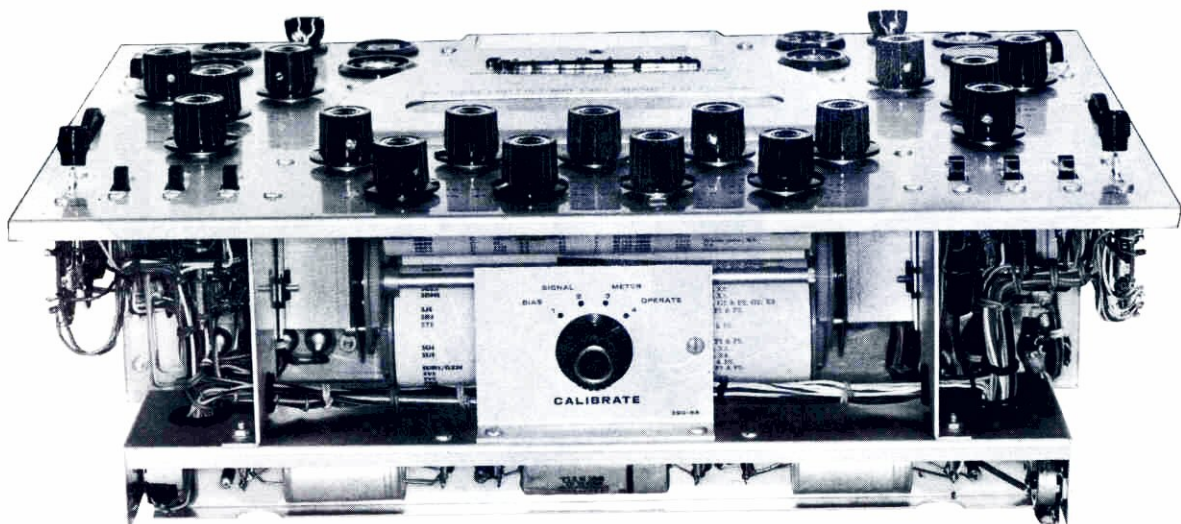

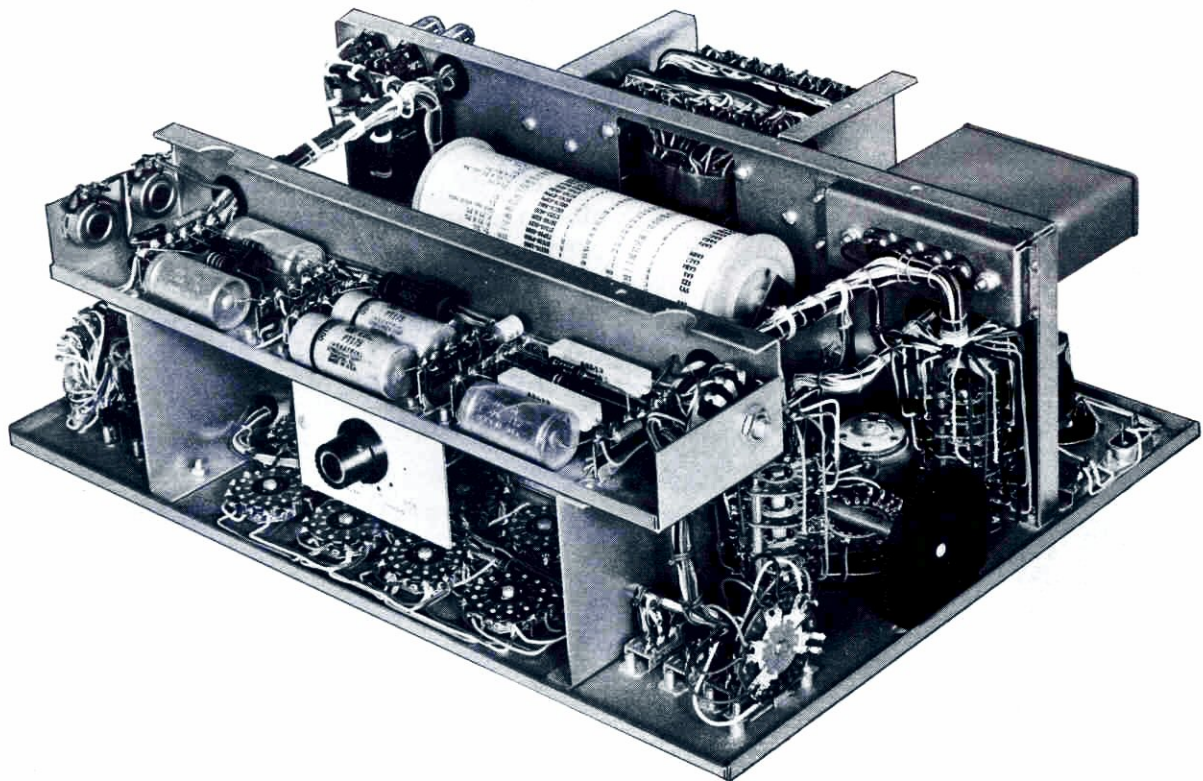
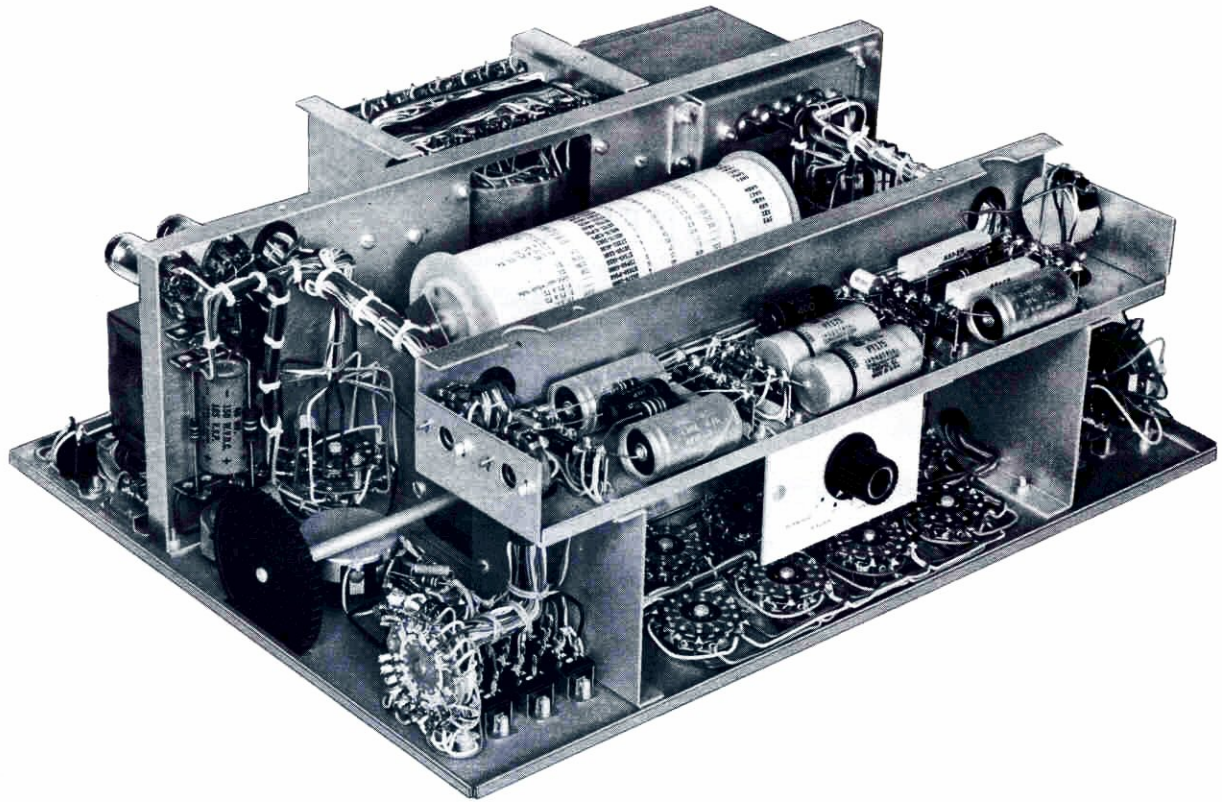

NOTES ON ASSEMBLY AND WIRING

The HEATHKIT Model TT-1 Tube Tester, when properly constructed, is an instrument capable of many years of satisfactory operation. We urge you to take the necessary time to assemble and wire the instrument carefully. Do not hurry the work and you will be rewarded with a greater sense of confidence both in the instrument and in your own workmanship.

This manual is supplied to assist you in completing the instrument with the least possible chance of error. We suggest that you scan through each manual carefully before any work is started. This will enable you to proceed with the work much faster and with greater accuracy. The large folded diagrams may be removed from the manual and attached to the wall above your working area but should be returned to the manual after the kit is completed.

UNPACK THE KIT CAREFULLY AND CHECK EACH PART AGAINST THE PARTS LIST. In so doing, you will become acquainted with the parts. Refer to the charts and other information on the inside covers of the manual to help you identify the components. If some shortage or

parts damage is found in checking the Parts List, please read the **REPLACEMENT** section and supply the information called for therein. Include all inspection slips in your letter to us.

The pictorials indicate actual chassis wiring and designate values of the component parts. We very strongly urge that the chassis layout and lead placement be followed exactly as shown. While the arrangement shown is probably not the only satisfactory layout, it is the result of considerable experimentation and trial. By following the pictorials of lead and component placement carefully, neat appearance and dependable operation are assured.

Space has been provided for you to check off each operation as it is completed. This is particularly important in wiring and it may prevent omissions or errors, especially where your work is interrupted frequently as the wiring progresses. When interrupted, it is often helpful to review the preceding two or three steps before continuing with the assembly. Some kit builders have also found it helpful to mark each lead in colored pencil on the pictorial as it is added.

GENERAL INSTRUCTIONS

SOCKET INSTALLATION

All sockets mounted on the panel of the TT-1 are of the ring mounting type to provide a neat panel appearance. The illustrations show the method of securing the mounting rings to the sockets. Before installing the ring, be sure the socket is seated properly against the panel. Careful inspection of each socket (after mounting) is highly recommended; it is much easier to adjust for proper seating before the wiring is installed.

Note carefully the positioning of the keyway when installing the sockets; a misaligned keyway or blank space could cause incorrect wiring. Note that in some cases each pin of the socket has a molded number for quick identification.

Extra rings have been provided for your convenience in the event a ring should become damaged during construction. Please note that one of the wavy rings is much larger than the rest; this ring is to be used on the large 7-pin socket having the pilot light socket incorporated in its design.

SHEET METAL PARTS AND HARDWARE

All sheet metal parts are punched and formed to close tolerances and should fit together without "forcing." In cases where one part must attach to two other parts, loosen the screws holding the two parts together and make the proper adjustments (the holes are punched slightly oversize for this purpose) rather than forcing the third part into place. Particular emphasis should be placed on this operation when installing the roll chart mechanism, as a misaligned roll chart bracket may rob you of the smooth action of which this mechanism is capable.

When the phrase "use 6-32 hardware" is used, it will be understood that the items involved will be a 6-32 nut, 6-32 BHMS (Binding Head Machine Screw), and #6 lockwasher(s). Exceptions to this are the speednuts and tapped switch frames where no lockwashers or nuts are required. With the exception of the internal tube sockets (3-48 hardware) and transformer mounting (8-32 hardware), all assembly is completed using 6-32 hardware. In all cases a lockwasher is placed directly under the nut. When mounting terminal strips, place one lockwasher between the terminal strip and chassis and one lockwasher under the nut. Two different lengths of 6-32 BHMS have been provided. Use the longer screws only in those steps where they are specifically called for.

SWITCH AND CONTROL INSTALLATION

Switches and controls are mounted with a lockwasher between the frame of the unit and the mounting surface, a flat washer on the opposite side of the mounting surface, and a control nut to secure the entire assembly. When the mounting of either a switch or a control is called for in the Step-By-Step assembly instructions, it will be understood that the above mentioned hardware will be used.

Examine the rotary switches and identify the straight line formed by the wafer mounting studs and shaft. In all cases, this line will either be parallel with or at a right angle to the bottom of the panel. When mounting the controls and switches, observe the terminal orientation as shown in the pictorial diagrams. Install the knob on the shaft as each unit is mounted and adjust the positioning of the switch as required to provide proper alignment of the knob pointer with the panel markings. The shaft of each switch has

one flat side on which the knob setscrew is to rest; proper installation of the knob may solve questions which arise pertaining to orientation of the switch.

NUMBERING SYSTEM AND ALPHABETICAL DESIGNATIONS

Each component (tube socket, switch, etc.) has been assigned a letter designation. Each terminal has been assigned a number designation. Thus, identification of any given terminal can be made quite easily by referring to the terminal as "TA-1" or "TA-2", for example. Reference to the pictorial diagrams will show that the octal socket has been designated as "TA". "TA-1" would therefore mean the connection is to be made to pin #1 of the octal socket, etc. The numbering of all tube socket terminals starts at the keyway, blank space, or orientation bump position and progresses clockwise around the socket (as seen from the terminal side). The numbering of the rotary switch lugs starts at one wafer mounting stud and progresses counter-clockwise around the switch (as viewed from the rear). The numbering system used for the multi-wafer switches is identical to that used for the single wafer switches except that an additional letter must be used to identify the switch wafer concerned. "A" corresponds to the first wafer (nearest the knob end of the switch), "B" corresponds to the second wafer, etc. For example, "Connect a wire to SKA-8" would mean to make the connection to terminal 8 on the wafer nearest the knob end of switch SK (PLATE switch). In locations where there are terminal lugs on both sides of the wafer at the same point, it will be understood that the connection is to be made to BOTH lugs.

Terminal strips are assigned a letter to designate the terminal strip and a number to designate the lug. A typical example might be "Connect a lead to A3", which would mean to connect a lead to lug #3 on terminal strip A.

The letter and number designations of each component should be marked on the sheet metal adjacent to the part as it is installed. A wax crayon is suitable for this purpose.

WIRING PROCEDURE AND COLOR CODE

Whenever hookup wire is called for it will be understood that the wire will be cut to the length specified, after which 1/4" of the insulation will

be removed from each end. In some cases it may seem that the length called for is excessively long for the intended application. In no case should this "extra" length be trimmed off; it is there to provide for future maintenance of the instrument. In all cases this "extra" length may be routed to provide a neat under-the-panel appearance. Study carefully the photographs of the completed unit so that you will be familiar with the general routing of leads. Notice that the "main highways" regarding lead dress are above the switches in most cases. This procedure is used to prevent the congestion caused by having too many leads dressed down tightly against the panel. Some steps will call for a "bare jumper" wire to be used. The excess lead length trimmed from resistors or capacitors may be used for this purpose, or, if you prefer, a short piece of stripped hookup wire will do. Extra yellow hook-up wire has been provided for this purpose.

In order to simplify troubleshooting operations, the wiring is color coded in a manner similar to EIA (RETMA) resistor code standards. Therefore, brown wire will be used to connect the #1 terminals of the tube sockets and selector

switches, red wire will be used to connect the #2 terminals, orange wire will be used to connect the #3 terminals, etc. (See inside of front cover.)

Leads on resistors and capacitors are generally much longer than required to make the indicated connections. The excess lead length should be cut off before the part is added to the circuit. In general, the leads should be just long enough to reach their terminating points.

Throughout the Step-By-Step instructions you will find (S) and (NS). These are the soldering instructions pertaining to that particular terminal. (S) mean solder; (NS) means DO NOT solder yet as more leads are to be connected to the terminal. The number associated with soldering (S) instructions denotes the number of leads tied to that terminal at the time of soldering. Example: (S-1) means there should be one lead connected to the terminal; (S-2) means there should be two leads connected to the terminal, etc.

PROPER SOLDERING PROCEDURE

Only a small percentage of HEATHKIT purchasers find it necessary to return an instrument for factory service. Of these kits, by far the largest proportion function improperly due to poor or improper soldering.

Correct soldering technique is extremely important. Good solder joints are essential if the performance engineered into the kit is to be fully realized.

Read the notes on soldering and wiring on the inside rear cover. If terminals are bright and clean and wires free of wax, frayed insulation and other foreign substances, no difficulty will be experienced in soldering. Crimp or other-

wise secure the wire (or wires) to the terminal, so a good joint is made without relying on solder for physical strength. To make a good solder joint, the clean tip of the soldering iron should be placed against the joint to be soldered so that the terminal is heated sufficiently to melt the solder. The solder is then placed against both the terminal and tip of the iron and will immediately flow out over the joint. Use only enough solder to cover wires at the junction; it is not necessary to fill the entire hole in the terminal with solder. Excess solder may flow into tube socket contacts, ruining the socket, or it may creep into switch contacts and destroy their spring action. Position the work so that gravity tends to keep the solder where you want it.

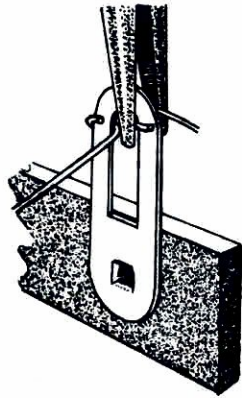

CRIMP WIRES

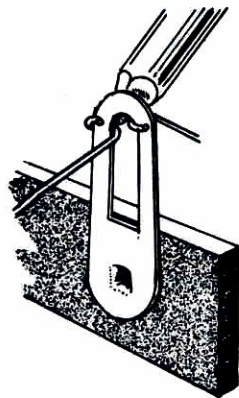

HEAT CONNECTION

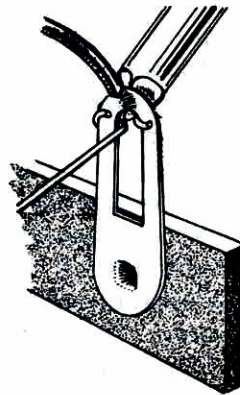

APPLY SOLDER

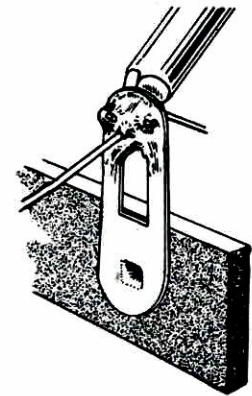

ALLOW SOLDER TO FLOW

A poor solder joint will usually be indicated by its appearance. The solder will stand up in a blob on top of the connection, with no evidence of flowing out caused by actual "wetting" of the contact. A crystalline or grainy texture on the solder surface, caused by movement of the joint

before it solidified is another evidence of a "cold" connection. In either event, reheat the joint until the solder flows smoothly over the entire junction, cooling to a smooth, bright appearance. The following illustration clearly indicates these two characteristics.

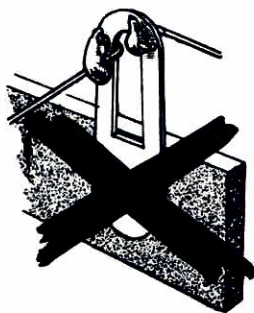

COLD SOLDER JOINT CONNECTION INSUFFICIENTLY HEATED

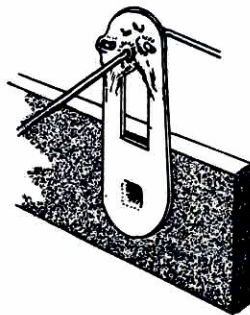

PROPER SOLDER CONNECTION

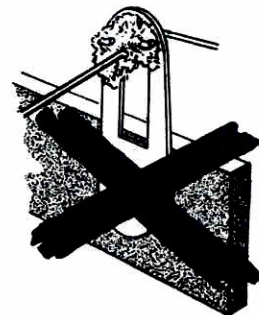

COLD SOLDER JOINT CONNECTION MOVED WHILE COOLING

ROSIN CORE SOLDER HAS BEEN SUPPLIED WITH THIS KIT. THIS TYPE OF SOLDER MUST BE USED FOR ALL SOLDERING IN THIS KIT. ALL GUARANTEES ARE VOIDED AND WE WILL NOT REPAIR OR SERVICE EQUIPMENT IN WHICH ACID CORE SOLDER OR PASTE FLUXES HAVE BEEN USED. IF ADDITIONAL SOLDER IS NEEDED, BE SURE TO PURCHASE ROSIN CORE (60:40 or 50:50 TIN-LEAD CONTENT) RADIO TYPE SOLDER.

A good, clean, well-tinned soldering iron is also important to obtain consistently perfect connections. For most wiring, a 30 to 100 watt iron, or the equivalent in a soldering gun, is very satisfactory. Small irons generally will not heat the connections enough to flow the solder smoothly over the joint and are recommended only for light work, such as on etched circuit boards, etc.

Keep the iron tip clean and bright. A clean rag may be used to wipe the tip occasionally during use.

Take these precautions and use reasonable care during assembly of the kit. This will insure the wonderful satisfaction of having the instrument operate perfectly the first time it is turned on.

Most kit builders find it helpful to separate the various parts into convenient categories. Muffin tins or molded egg cartons make convenient trays for small parts. Resistors and capacitors may be placed with their lead ends inserted in the edge of a piece of corrugated cardboard until they are needed. Values can be written on the cardboard next to each component. The illustration shows one method that may be used.

We suggest that you do the following before work is started:

1. Read several steps ahead of the actual step being performed. This will familiarize you with the relationship of the subsequent operations.
2. Lay out all parts so that they are readily available.
3. Provide yourself with good quality tools. Basic tool requirements consist of a screwdriver with a 1/4" blade; a small screwdriver with a 1/8" blade; long-nose pliers; wire cutters, preferably separate diagonal cutters; a pen knife or a tool for stripping insulation from wires; a soldering iron (or gun) and rosin core solder. A set of nut drivers and a nut starter, while not necessary, will aid extensively in construction of the kit.

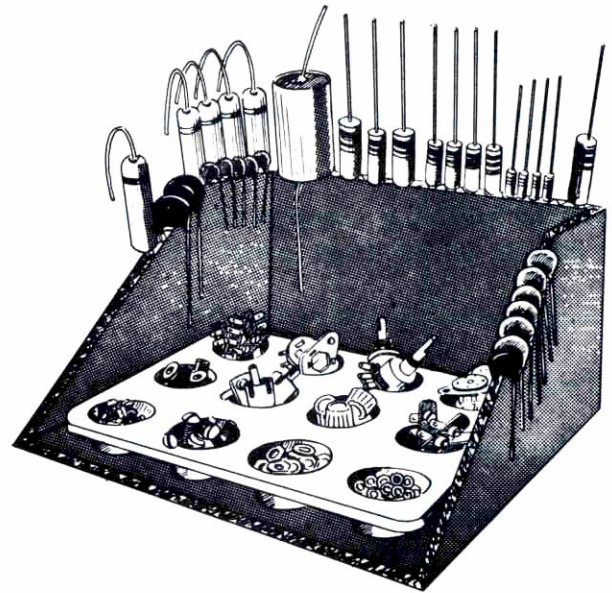

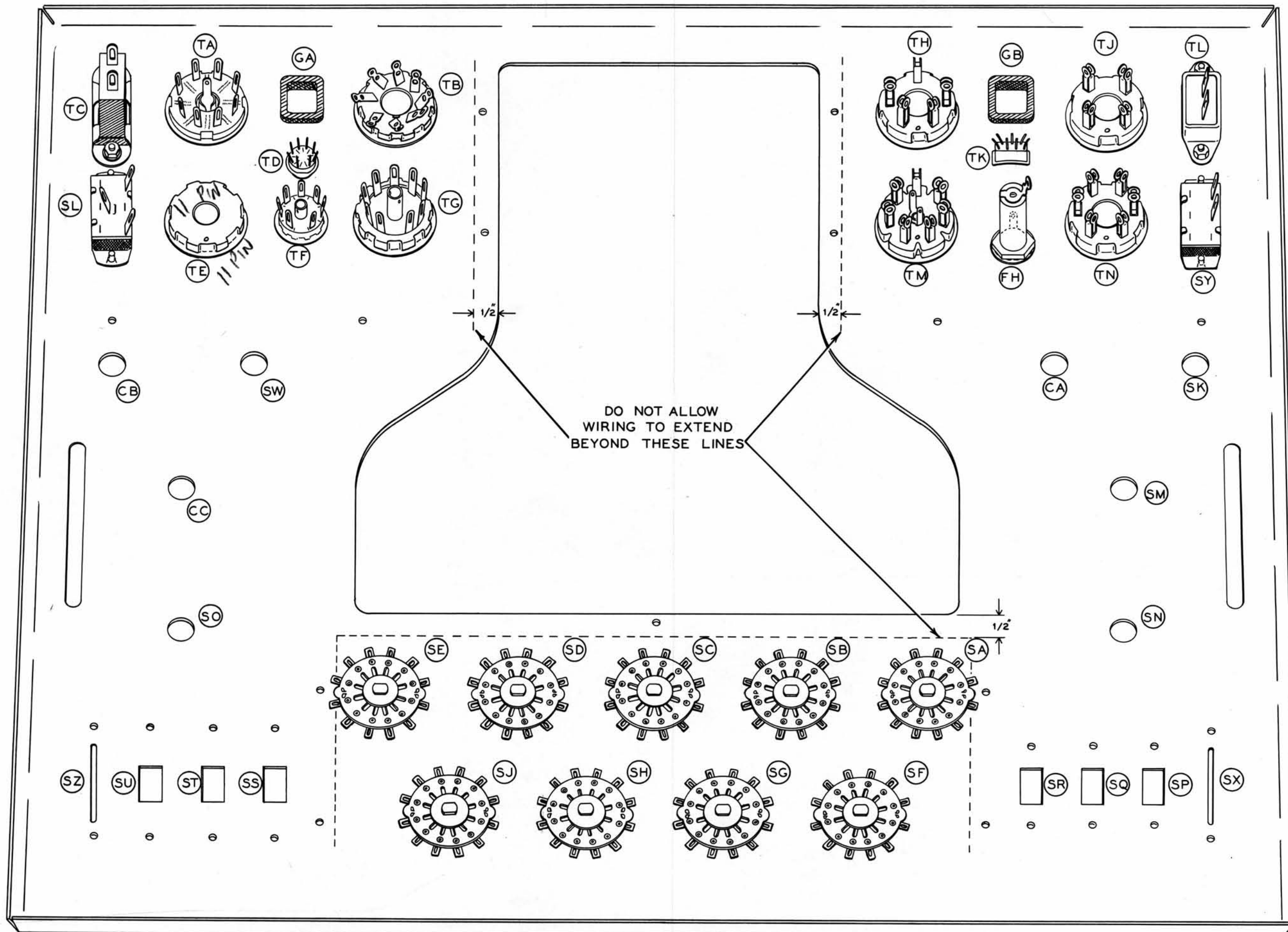

TUBE SOCKET INSTALLATION

Mount the tube sockets in their respective locations, noting carefully the terminal orientation. Tube socket number starts at the blank space or orientation bump and proceeds clockwise around the socket (as viewed from the rear). In all cases the blank space or orientation bump is to be placed toward the bottom of the panel. The 7-pin subminiature socket is mounted with the orientation bump on the front of the socket placed adjacent to the black dot on the panel. This will place four terminals toward the bottom of the panel and three terminals toward the top of the panel.

When installing the 3/4" grommets in the square holes, push the grommets into the corners, alternating from one corner to another until a uniformly square appearance is presented.

NOTE: Place a cloth on the workbench to prevent marring the panel.

Mount the following components in the top left hand corner of the front panel. See Figure 1.

- () 8-pin subminiature socket TD.
- () 7-pin miniature socket TF.
- () Loctal socket TA.
- () Blank socket TE.

11 PIN AT (TT-1A)

- () Octal socket TB.
- () 9-pin miniature socket TG.
- () 3/4" grommet GA.
- () Line output connector TC. Use 6-32 hardware.
- () SPDT slide switch SL. Use 6-32 BHMS.

Mount the following components in the top right hand corner of the front panel. See Figure 1.

- () 7-pin subminiature socket TK.
- () 5-pin socket TH.
- () 4-pin socket TJ.
- () Large 7-pin socket TM.
- () 6-pin socket TN.
- () 3/4" grommet GB.
- () Line input connector TL. Use 6-32 hardware.
- () SPST ON-OFF slide switch SY. Use 6-32 BHMS.
- () Fuse holder FH (rubber washer on outside of panel). Orient as shown in Figure 1.

Figure 1 BOTTOM

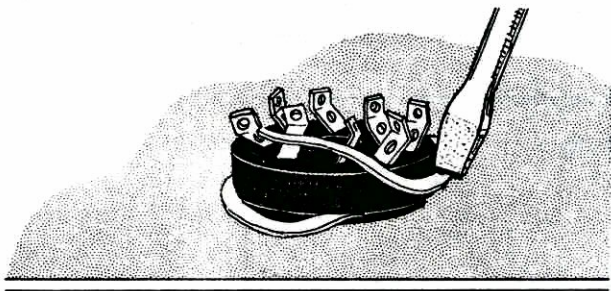

OCTAL SIZE
SOCKETS

Detail 1A

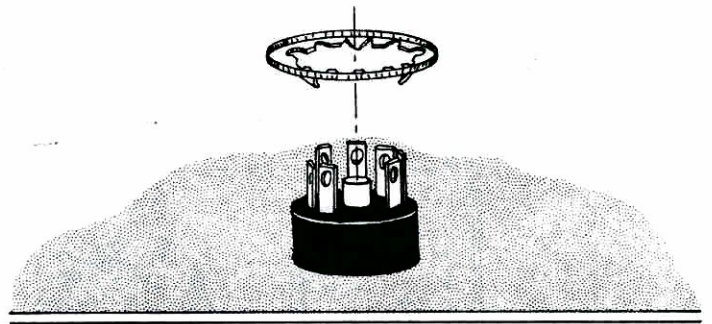

7-PIN MINIATURE
SOCKET

Detail 1B

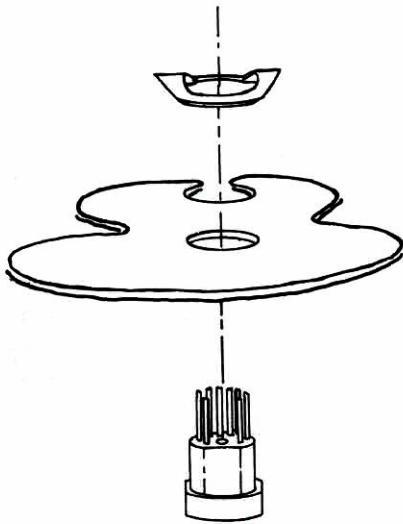

8-PIN
SUB-MINIATURE
SOCKET

Detail 1C

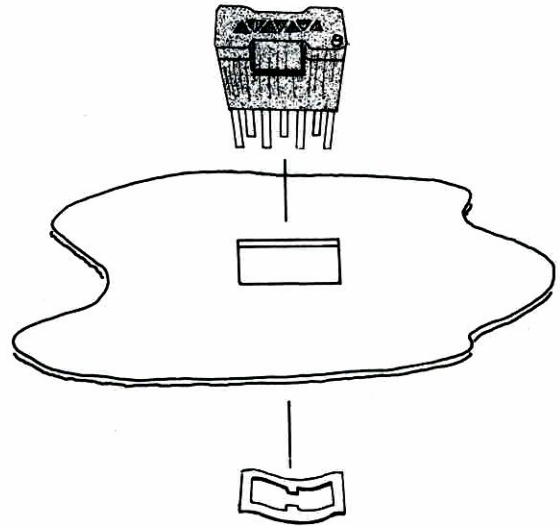

7-PIN SUB-MINIATURE
SOCKET

Detail 1D

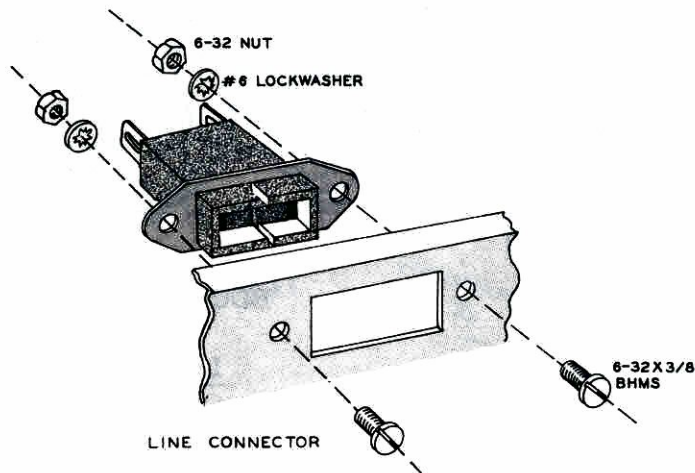

Detail 1E

TUBE SOCKET WIRING

Using the wire colors indicated, install tube socket leads as follows:

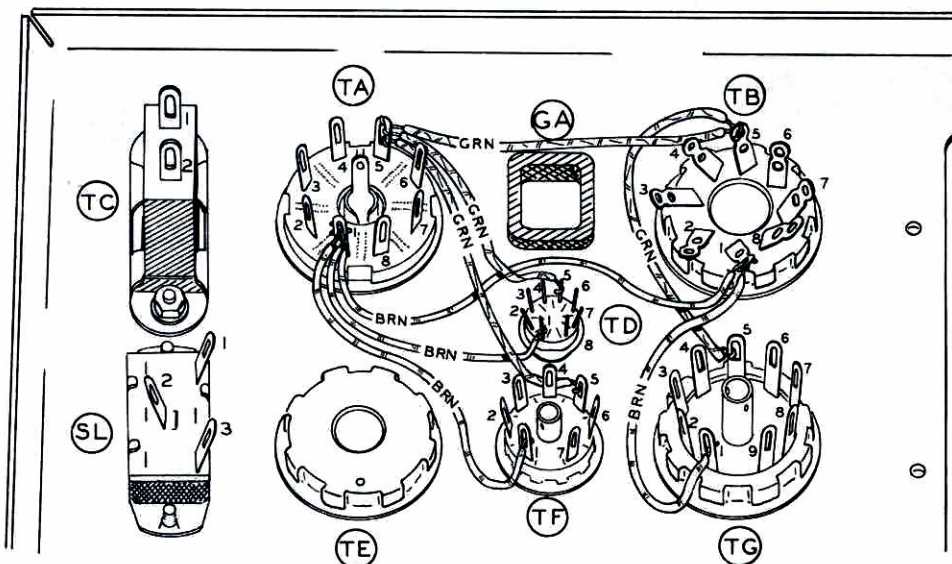

Figure 2

BROWN wire - #1 terminals

GREEN wire - #5 terminals

Length	From	To
() 3"	TG1 (NS)	TB1 (NS)
() 4 1/2"	TB1 (NS)	TA1 (NS)
() 2 1/2"	TA1 (NS)	TD1 (S-1)
() 3 1/2"	TA1 (S-3)	TF1 (S-1)

Length	From	To
() 4"	TG5 (NS)	TB5 (NS)
() 4"	TB5 (NS)	TA5 (NS)
() 2 1/2"	TA5 (NS)	TD5 (S-1)
() 3 3/4"	TA5 (S-3)	TF5 (S-1)

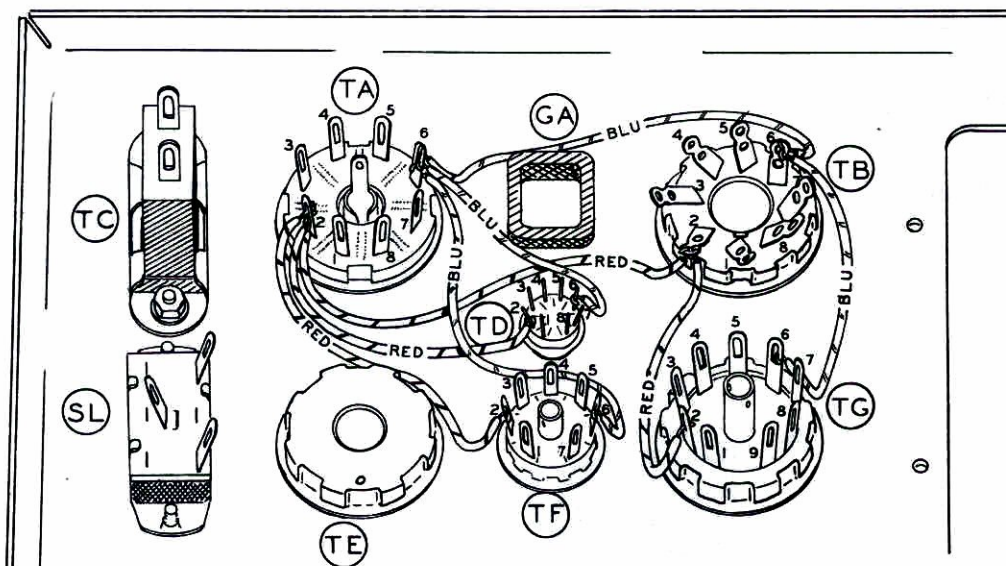

Figure 3

RED wire - #2 terminals

BLUE wire - #6 terminals

Length	From	To
() 3"	TG2 (NS)	TB2 (NS)
() 4 1/2"	TB2 (NS)	TA2 (NS)
() 3"	TA2 (NS)	TD2 (S-1)
() 4"	TA2 (S-3)	TF2 (S-1)

Length	From	To
() 3"	TG6 (NS)	TB6 (NS)
() 4"	TB6 (NS)	TA6 (NS)
() 2 1/4"	TA6 (NS)	TD6 (S-1)
() 3 1/2"	TA6 (S-3)	TF6 (S-1)

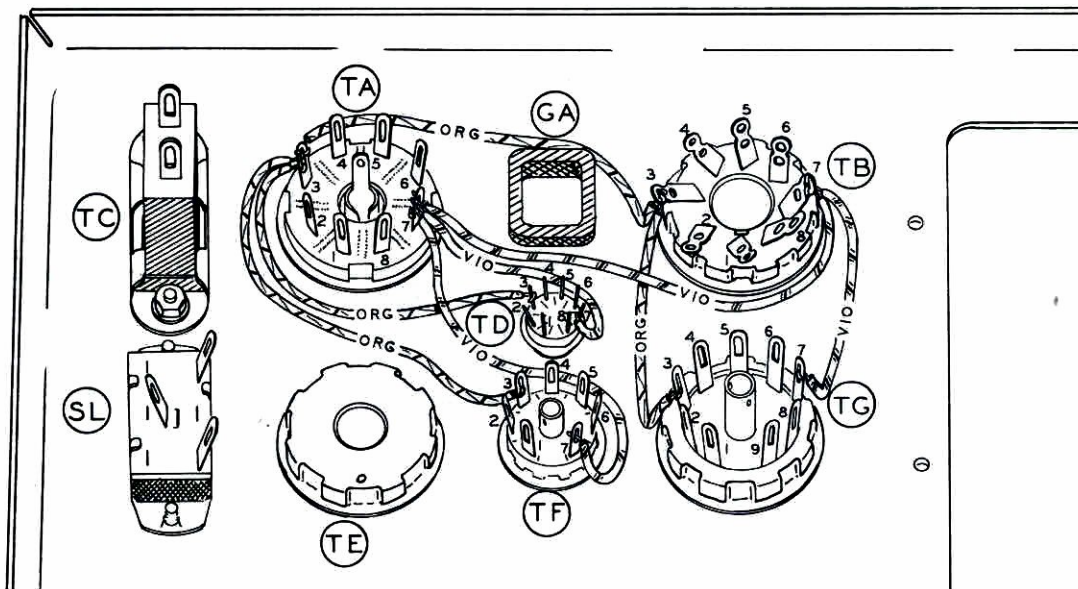

Figure 4

ORANGE wire - #3 terminals

VIOLET wire - #7 terminals

<u>Length</u>	<u>From</u>	<u>To</u>	<u>Length</u>	<u>From</u>	<u>To</u>
() 2 3/4"	TG3 (NS)	TB3 (NS)	() 2 1/2"	TG7 (NS)	TB7 (NS)
() 4 1/2"	TB3 (NS)	TA3 (NS)	() 4 1/4"	TB7 (NS)	TA7 (NS)
() 3 1/2"	TA3 (NS)	TD3 (S-1)	() 2 1/4"	TA7 (NS)	TD7 (S-1)
() 4"	TA3 (S-3)	TF3 (S-1)	() 3 1/2"	TA7 (S-3)	TF7 (S-1)

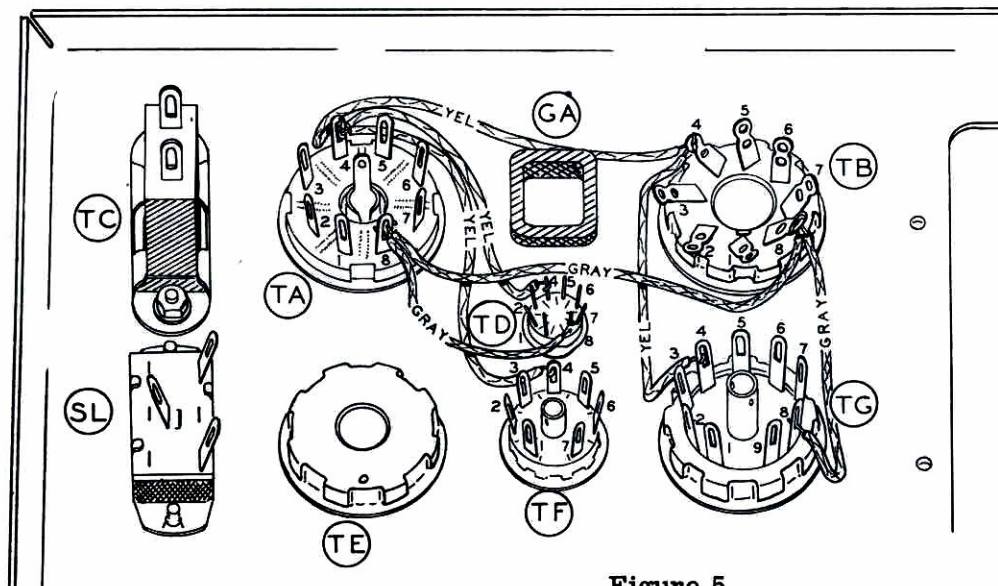

Figure 5

YELLOW wire - #4 terminals

GRAY wire - #8 terminals

<u>Length</u>	<u>From</u>	<u>To</u>	<u>Length</u>	<u>From</u>	<u>To</u>
() 3"	TG4 (NS)	TB4 (NS)	() 2 1/4"	TG8 (NS)	TB8 (NS)
() 4"	TB4 (NS)	TA4 (NS)	() 4 1/4"	TB8 (S-2)	TA8 (NS)
() 3"	TA4 (NS)	TD4 (S-1)	() 2 1/2"	TA8 (S-2)	TD8 (S-1)
() 3 3/4"	TA4 (S-3)	TF4 (S-1)			

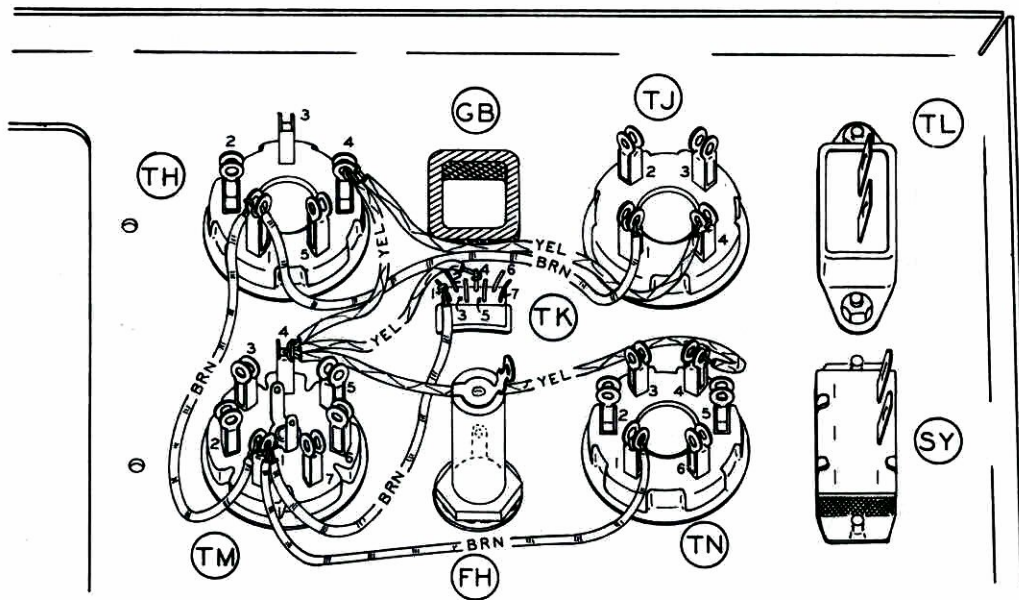

Figure 6

BROWN wire - #1 terminals

YELLOW wire - #4 terminals

<u>Length</u>	<u>From</u>	<u>To</u>	<u>Length</u>	<u>From</u>	<u>To</u>
() 3 1/2"	TM1 (NS)	TH1 (NS)	() 2 1/2"	TM4 (NS)	TH4 (NS)
() 4"	TH1 (S-2)	TJ1 (S-1)	() 4"	TH4 (S-2)	TJ4 (S-1)
() 4 1/4"	TM1 (NS)	TN1 (S-1)	() 2 1/4"	TM4 (NS)	TK4 (S-1)
() 3 1/4"	TM1 (NS)	TK1 (S-1)	() 4 3/4"	TM4 (NS)	TN4 (S-1)

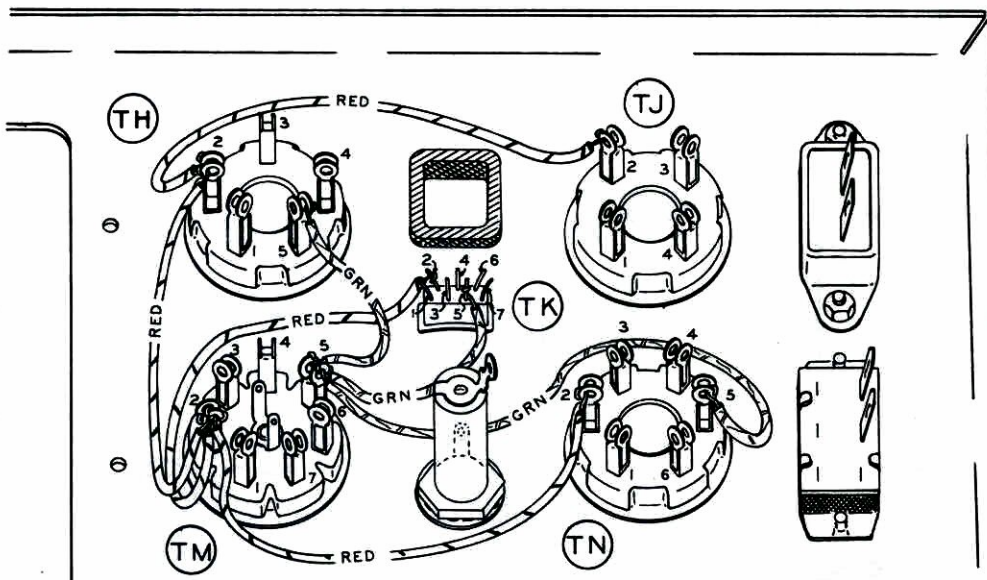

Figure 7

RED wire - #2 terminals

GREEN wire - #5 terminals

<u>Length</u>	<u>From</u>	<u>To</u>	<u>Length</u>	<u>From</u>	<u>To</u>
() 3 1/4"	TM2 (NS)	TH2 (NS)	() 2"	TM5 (NS)	TH5 (S-1)
() 4 3/4"	TH2 (S-2)	TJ2 (S-1)	() 2 1/4"	TM5 (NS)	TK5 (S-1)
() 5"	TM2 (NS)	TN2 (S-1)	() 5"	TM5 (NS)	TN5 (S-1)
() 3 3/4"	TM2 (NS)	TK2 (S-1)			

ORANGE wire - #3 terminals

VIOLET wire - #7 terminals

<u>Length</u>	<u>From</u>	<u>To</u>
() 3 3/4"	TM3 (NS)	TH3 (NS)
() 5"	TH3 (S-2)	TJ3 S-1)
() 3"	TM3 (NS)	TK3 (S-1)
() 5"	TM3 (NS)	TN3 (S-1)

<u>Length</u>	<u>From</u>	<u>To</u>
() 2 3/4"	TM7 (NS)	TK7 (S-1)

BLUE wire - #6 terminals

WHITE wire - Line cord socket to fuse holder.

<u>Length</u>	<u>From</u>	<u>To</u>
() 3 1/2"	TM6 (NS)	TK6 (S-1)
() 4 1/4"	TM6 (NS)	TN6 (S-1)

<u>Length</u>	<u>From</u>	<u>To</u>
() 3"	TL2 (NS)	SY2 (S-1)
() 5"	SY1 (S-1)	FH2 (S-1)

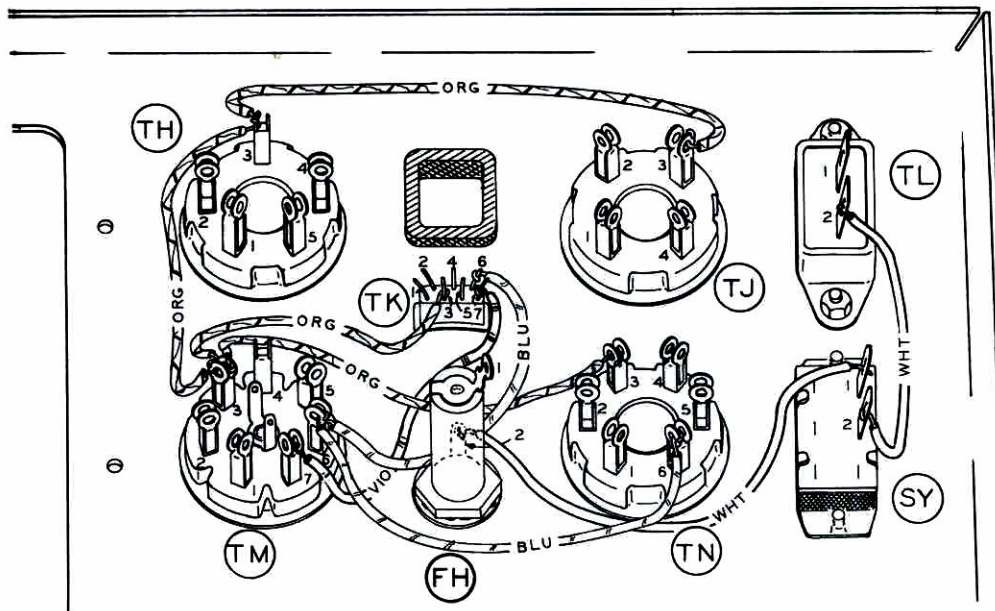

Figure 8

Wiring mistakes or short circuits in the tube socket wiring will be much easier to locate and correct before proceeding further with the assembly of the TT-1. Any type of continuity tester or ohmmeter is suitable for this purpose. If no instrument of this nature is at hand, a simple continuity tester may be quickly made up from ordinary flashlight components.

The tube sockets are wired correctly if:

1. All socket pins of each group show continuity between like numbers; that is, any #1 pin should show continuity to all other #1 pins of its group, any #2 pin to all other #2 pins, etc.

2. There is no continuity from the panel to any pin, regardless of its number, in either group.

The tube sockets are wired incorrectly if:

1. Continuity is shown between pins of different numbers; that is, the #1 pins should not be connected to any other number, the #2 pins should not be connected to any other number, etc.
2. There is continuity shown from the panel to any pin, regardless of number.

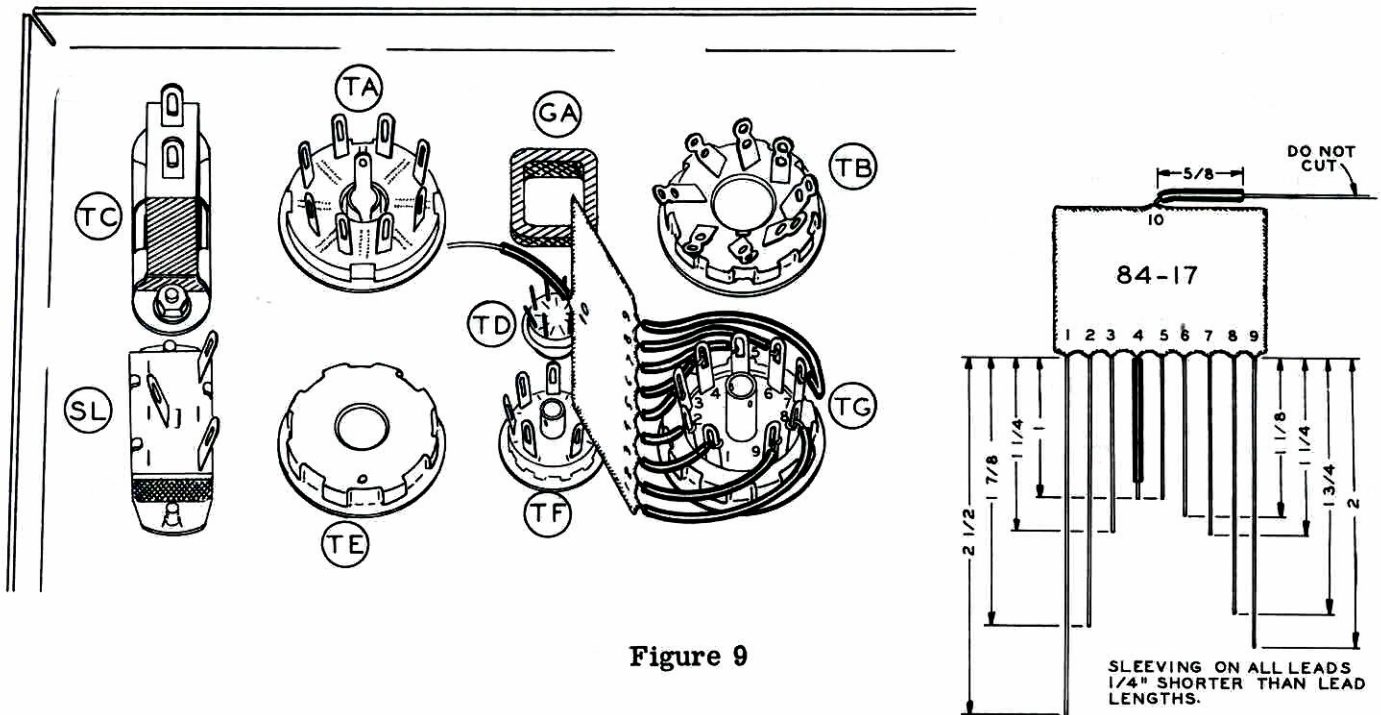

Figure 9

INSTALLATION OF P.E.C. OSCILLATION SUPPRESSORS

- () Identify the two P.E.C.'s (#84-17 and #84-18) and trim the leads to the lengths indicated. DO NOT cut the common leads. Cover each lead with sleeving, as shown in Figures 9 and 10.

Place the body of the P.E.C. as shown and make connections as follows:

9-pin tube socket TG (#84-17)

	<u>P.E.C. Lead</u>	<u>Connect to</u>
()	1	TG8 (NS)
()	2	TG9 (NS)
()	3	TG1 (NS)
()	4	TG2 (NS)
()	5	TG3 (NS)
()	6	TG4 (NS)
()	7	TG5 (NS)
()	8	TG6 (NS)
()	9	TG7 (NS)

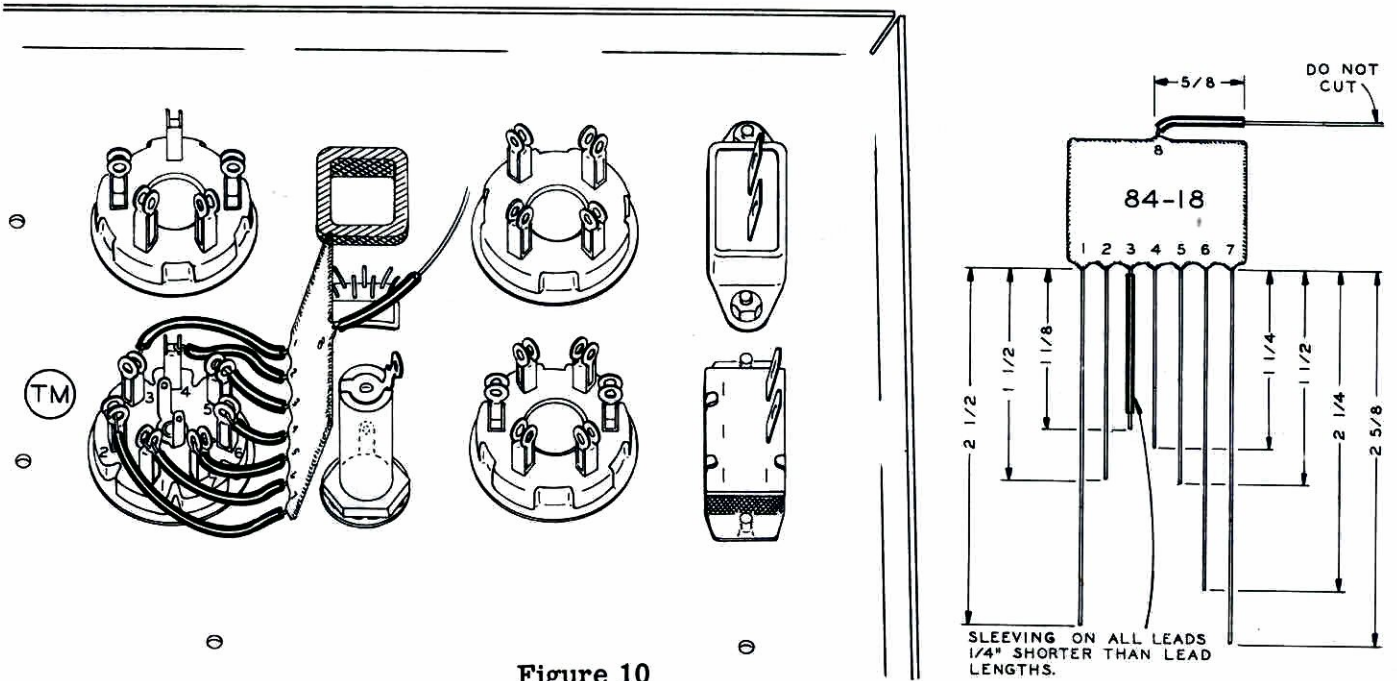

Figure 10

7-pin tube socket TM (#84-18)

	<u>P.E.C. Lead</u>	<u>Connect to</u>
()	1	TM3 (NS)
()	2	TM4 (NS)
()	3	TM5 (NS)
()	4	TM6 (NS)
()	5	TM7 (NS)
()	6	TM1 (NS)
()	7	TM2 (NS)

The common leads (#10 and #8 respectively) are not connected at this time.

- () Repeat the continuity and short circuit testing on the 9 and 7-pin tube sockets. Also, test from each tube pin to the common lead of the P.E.C. concerned. There should be no DC path through the P.E.C.'s.

SELECTOR SWITCH INSTALLATION AND WIRING

- () Mount the nine SELECTOR switches (#R63-217) as shown in Detail 2 and Figure 1. Observe the terminal orientation closely. When installing the knobs, rotate the shaft so that the rotor contact is in the long, or common, clip (lug #4). The knob pointer should then be at the "0" position.
- () The leads connecting the SELECTOR switches together may all be prepared in advance. Cut eight 3 3/4" lengths of each of the ten colors of wire, except green. Green will be used twice, so sixteen lengths of green wire are required. Strip 1/4" of the insulation from the ends of each lead.

Terminal #4 of the SELECTOR Switches is not wired at this time. This is the common terminal which connects the various circuits to the proper tube pins. Skipping terminal #4 moves the color code arrangement up one step that is, the #5 terminals will be connected with yellow wire (instead of green), the #6 terminals will be connected with green wire (instead of blue), etc.

Refer to Figure 11.

BROWN leads - #1 terminals

<u>From</u>	<u>To</u>
() SA1 (S-1)	SB1 (NS)
() SB1 (S-2)	SC1 (NS)
() SC1 (NS)	SD1 (NS)
() SD1 (S-2)	SE1 (S-1)
() SF1 (NS)	SG1 (NS)
() SG1 (NS)	SH1 (NS)
() SH1 (S-2)	SJ1 (S-1) NS
() SC1 (S-3)	SG1 (S-3)

BLUE leads - #7 terminals

<u>From</u>	<u>To</u>
() SA7 (S-1)	SB7 (NS)
() SB7 (S-2)	SC7 (NS)
() SC7 (NS)	SD7 (NS)
() SD7 (S-2)	SE7 (S-1)
() SF7 (NS)	SG7 (NS)
() SG7 (NS)	SH7 (NS)
() SH7 (S-2)	SJ7 (S-1) NS
() SC7 (S-3)	SG7 (S-3)

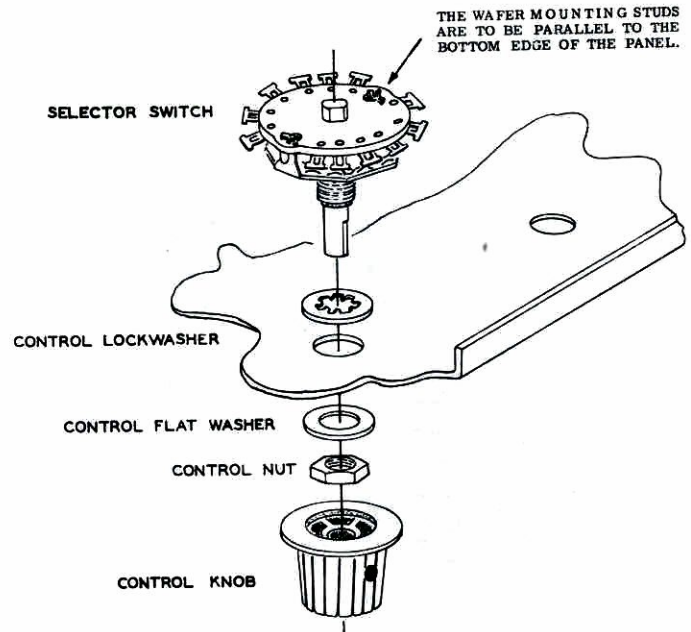

Detail 2

Refer to Figure 12.

RED leads - #2 terminals

<u>From</u>	<u>To</u>
() SA2 (S-1)	SB2 (NS)
() SB2 (S-2)	SC2 (NS)
() SC2 (NS)	SD2 (NS)
() SD2 (S-2)	SE2 (S-1)
() SF2 (NS)	SG2 (NS)
() SG2 (NS)	SH2 (NS)
() SH2 (S-2)	SJ2 (S-1) NS
() SC2 (S-3)	SG2 (S-3)

VIOLET leads - #8 terminals

<u>From</u>	<u>To</u>
() SA8 (S-1)	SB8 (NS)
() SB8 (S-2)	SC8 (NS)
() SC8 (NS)	SD8 (NS)
() SD8 (S-2)	SE8 (S-1)
() SF8 (NS)	SG8 (NS)
() SG8 (NS)	SH8 (NS)
() SH8 (S-2)	SJ8 (S-1) NS
() SC8 (S-3)	SG8 (S-3)

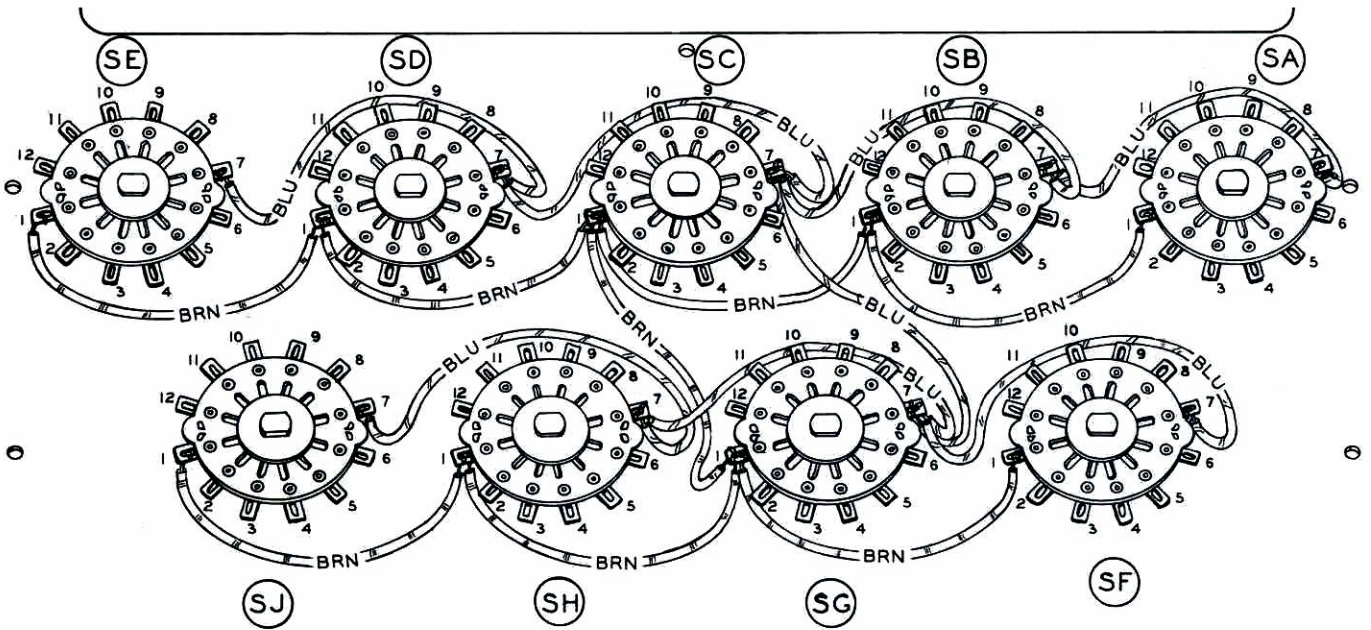

Figure 11

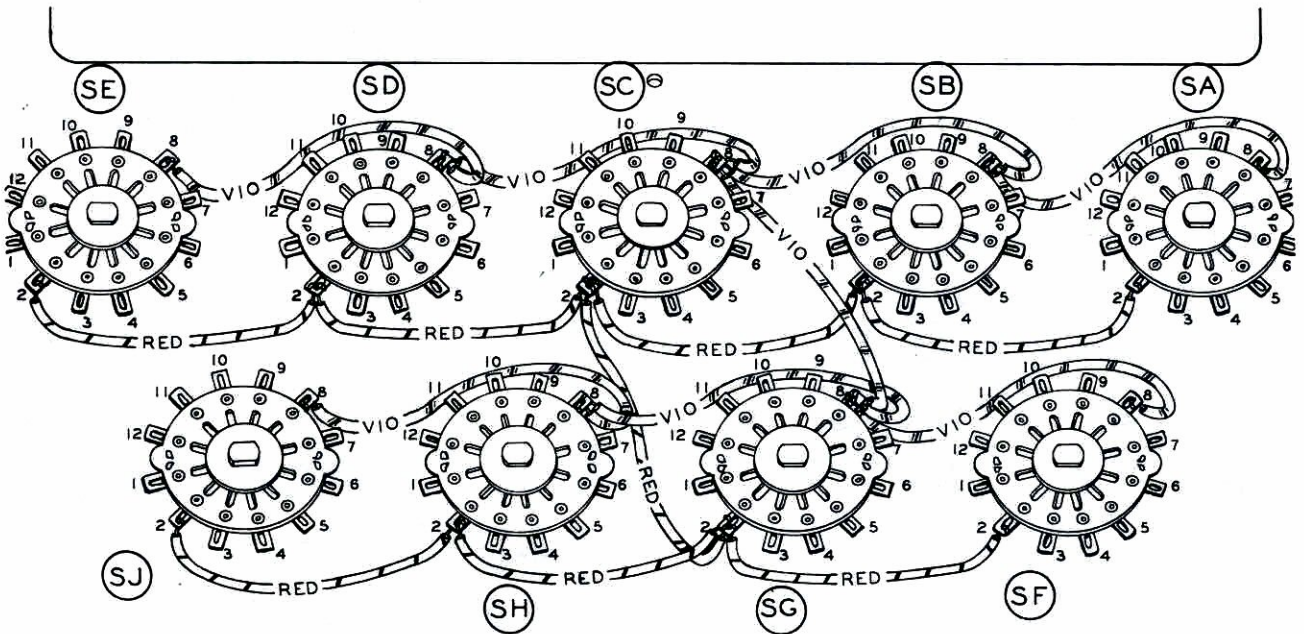

Figure 12

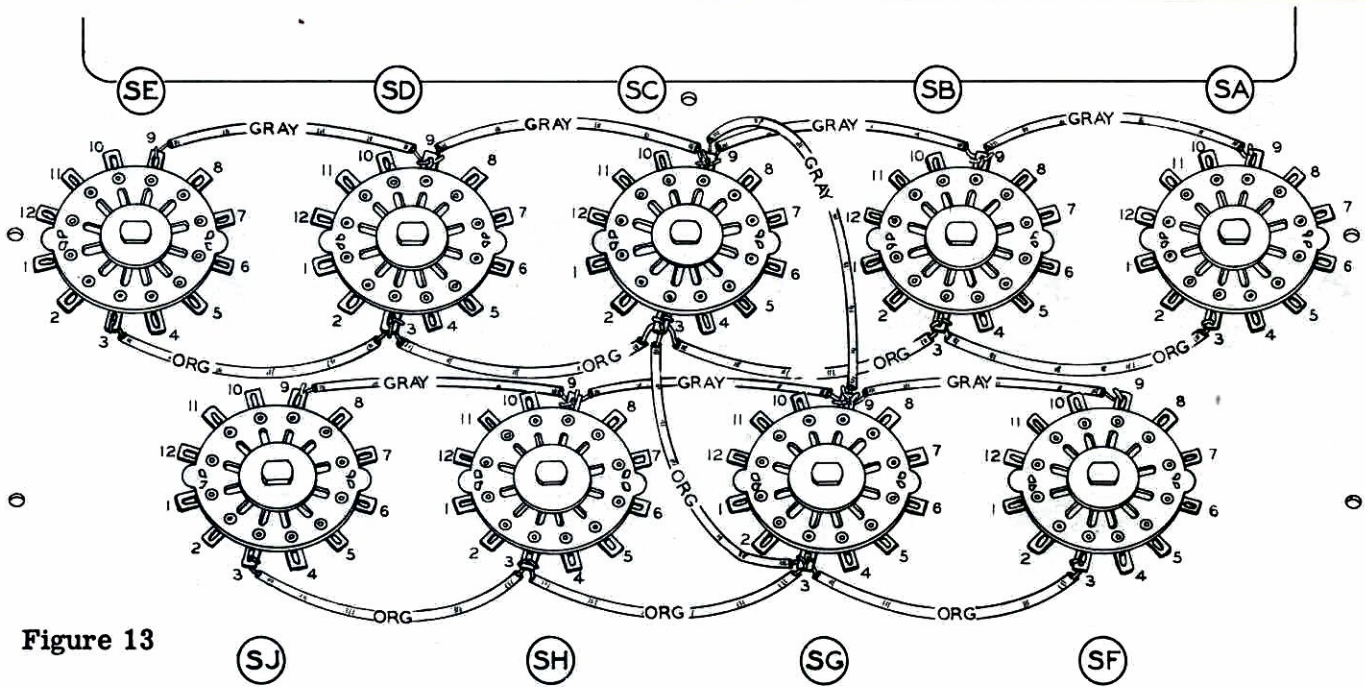

Figure 13

Refer to Figure 13.

BOTTOM

GRAY leads - #9 terminals

ORANGE leads - #3 terminals

<u>From</u>	<u>To</u>	<u>From</u>	<u>To</u>
() SA9 (S-1)	SB9 (NS)	() SA3 (S-1)	SB3 (NS)
() SB9 (S-2)	SC9 (NS)	() SB3 (S-2)	SC3 (NS)
() SC9 (NS)	SD9 (NS)	() SC3 (NS)	SD3 (NS)
() SD9 (S-2)	SE9 (S-1)	() SD3 (S-2)	SE3 (S-1)
() SF9 (NS)	SG9 (NS)	() SF3 (NS)	SG3 (NS)
() SG9 (NS)	SH9 (NS)	() SG3 (NS)	SH3 (NS)
() SH9 (S-2)	SJ9 (S-1) <i>NS</i>	() SH3 (S-2)	SJ3 (S-1) <i>NS</i>
() SC9 (S-3)	SG9 (S-3)	() SC3 (S-3)	SG3 (S-3)

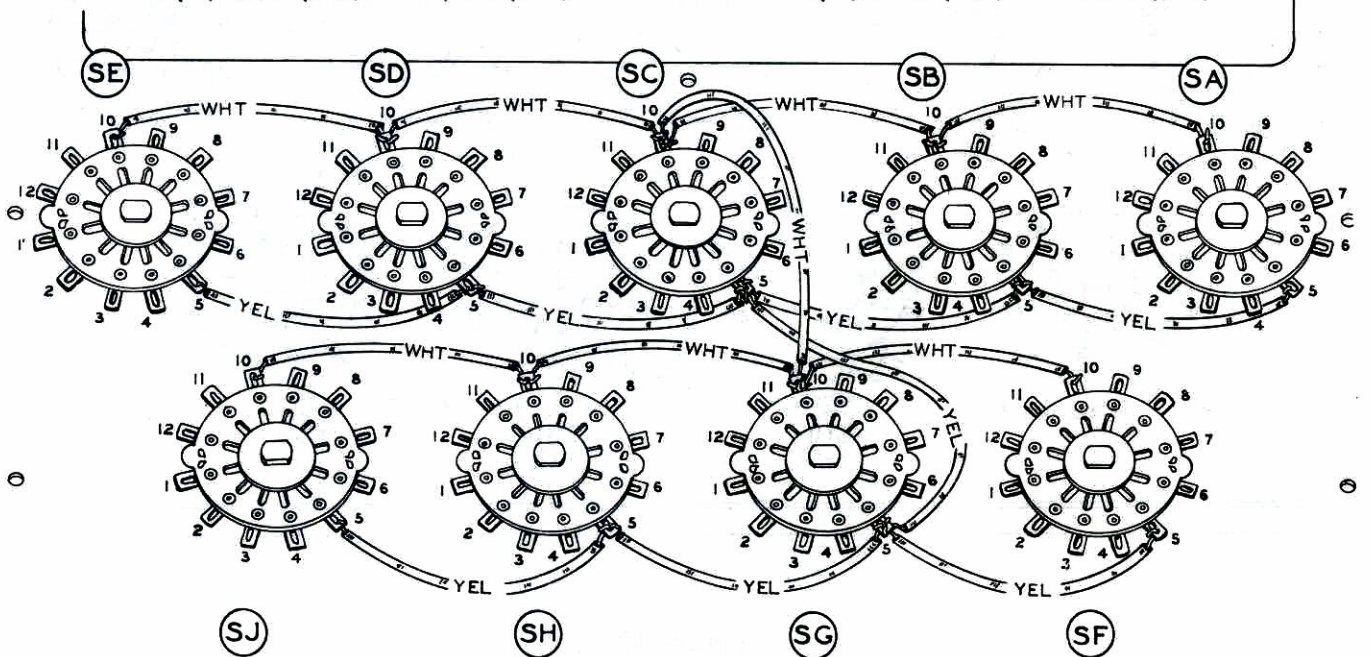

Figure 14

BOTTOM

Refer to Figure 14. NOTE: Remember to skip terminal #4.

WHITE leads - #10 terminals

YELLOW leads - #5 terminals

<u>From</u>	<u>To</u>	<u>From</u>	<u>To</u>
() SA10 (S-1)	SB10 (NS)	() SA5 (S-1)	SB5 (NS)
() SB10 (S-2)	SC10 (NS)	() SB5 (S-2)	SC5 (NS)
() SC10 (NS)	SD10 (NS)	() SC5 (NS)	SD5 (NS)
() SD10 (S-2)	SE10 (S-1)	() SD5 (S-2)	SE5 (S-1)
() SF10 (NS)	SG10 (NS)	() SF5 (NS)	SG5 (NS)
() SG10 (NS)	SH10 (NS)	() SG5 (NS)	SH5 (NS)
() SH10 (S-2)	SJ10 (S-1)-NS	() SH5 (S-2)	SJ5 (S-1)-NS
() SC10 (S-3)	SG10 (S-3)	() SC5 (S-3)	SG5 (S-3)

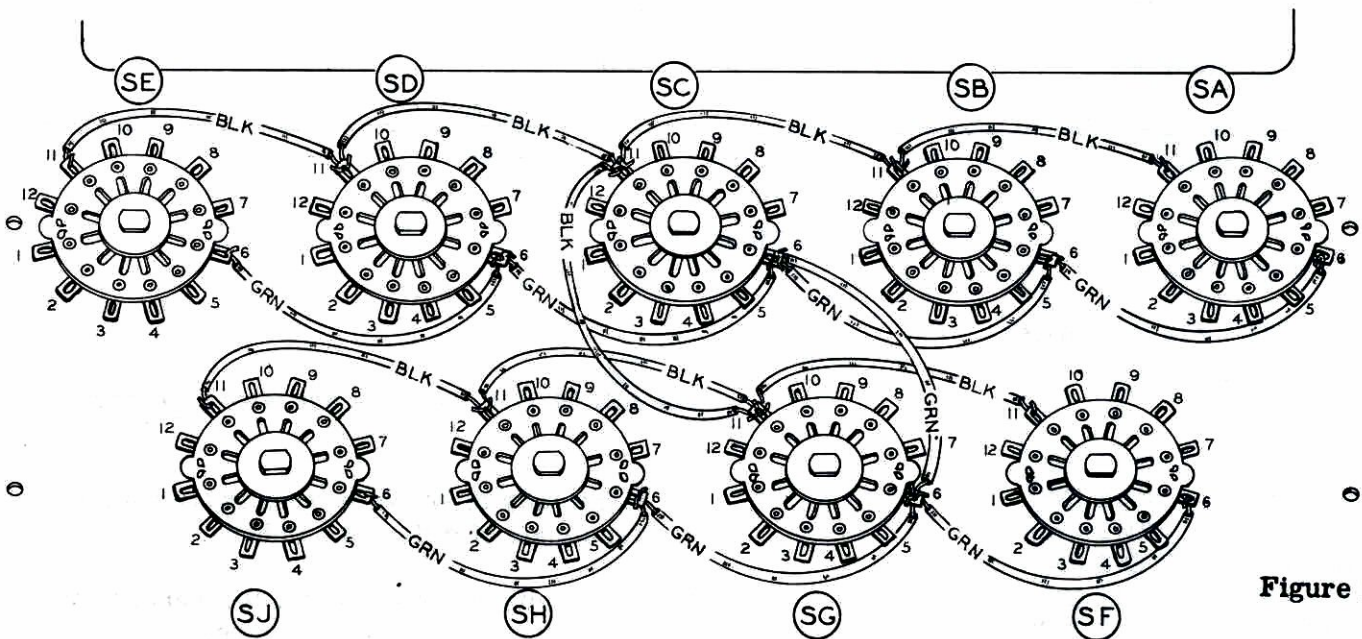

Figure 15

BOTTOM

Refer to Figure 15.

BLACK leads - #11 terminals

GREEN leads - #6 terminals

<u>From</u>	<u>To</u>	<u>From</u>	<u>To</u>
() SA11 (S-1)	SB11 (NS)	() SA6 (S-1)	SB6 (NS)
() SB11 (S-2)	SC11 (NS)	() SB6 (S-2)	SC6 (NS)
() SC11 (NS)	SD11 (NS)	() SC6 (NS)	SD6 (NS)
() SD11 (S-2)	SE11 (S-1)	() SD6 (S-2)	SE6 (S-1)
() SF11 (NS)	SG11 (NS)	() SF6 (NS)	SG6 (NS)
() SG11 (NS)	SH11 (NS)	() SG6 (NS)	SH6 (NS)
() SH11 (S-2)	SJ11 (S-1)-NS	() SH6 (S-2)	SJ6 (S-1)-NS
() SC11 (S-3)	SG11 (S-3)	() SC6 (S-3)	SG6 (S-3)

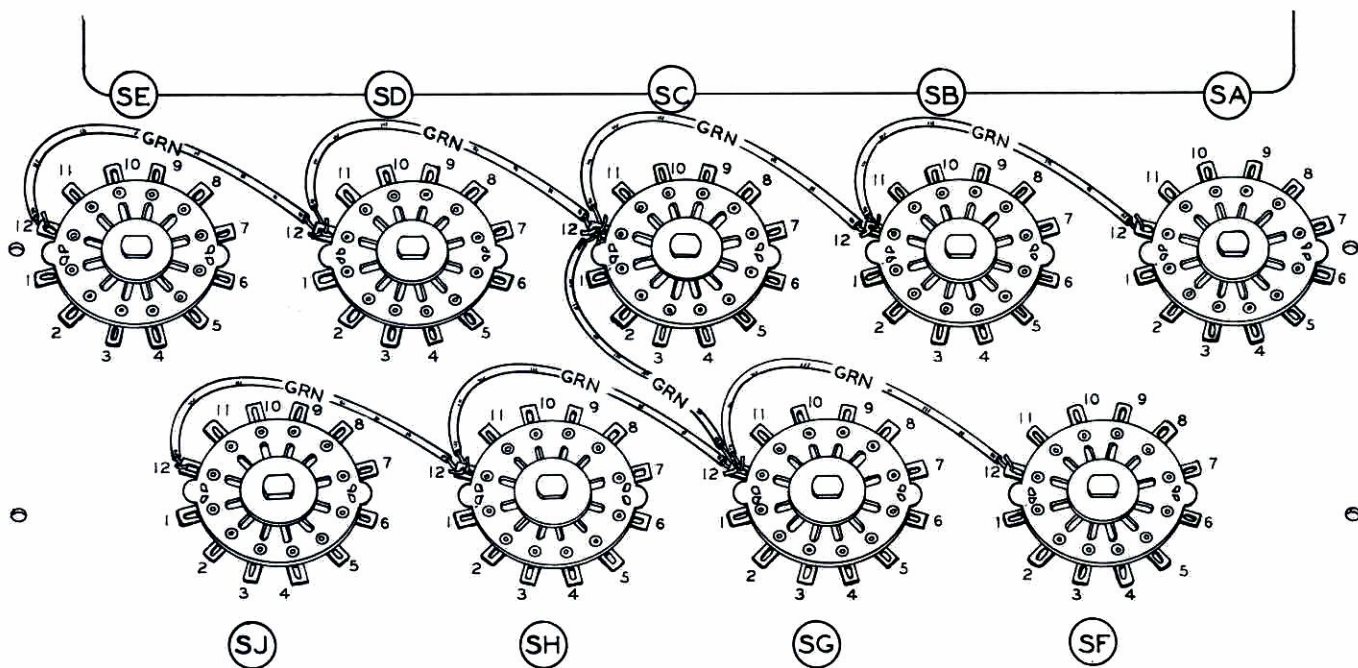

BOTTOM

Figure 16

Refer to Figure 16.

GREEN leads - #12 terminals

From	To
() SA12 (S-1)	SB12 (NS)
() SB12 (S-2)	SC12 (NS)
() SC12 (NS)	SD12 (NS)
() SD12 (S-2)	SE12 (S-1)
() SF12 (NS)	SG12 (NS)
() SG12 (NS)	SH12 (NS)
() SH12 (S-2)	SJ12 (S-1) - NS
() SC12 (S-3)	SG12 (S-3)

The SELECTOR switches are wired incorrectly if:

1. Continuity is shown between any two or more terminals of different numbers.
2. Continuity is shown from the panel to any terminal, regardless of number.

The continuity and short circuit testing procedure outlined for the tube socket wiring should be applied now to the SELECTOR switches. Be sure the switch rotors are in the long (common) clip (#4) during the testing procedure.

INSTALLATION OF TUBE SOCKET TO TUBE SOCKET HARNESS

- () Identify the tube socket to tube socket cable harness (#134-14). Examine the harness carefully to determine which end is to be connected to socket TM. See Figure 17.

The SELECTOR switches are wired correctly if:

1. Continuity is shown between all terminals of the same number (except #4).
2. Continuity is NOT shown from the panel to any terminal, regardless of number.

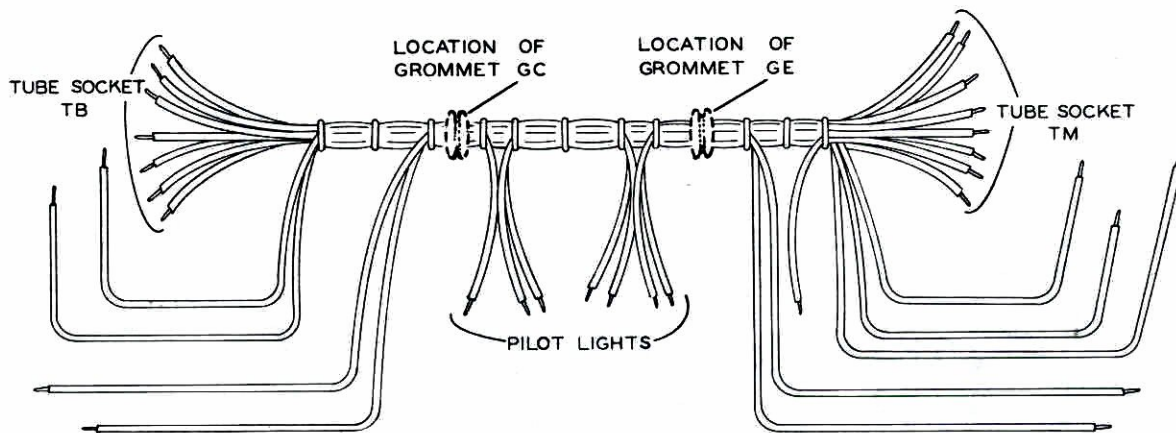

TUBE SOCKET TO TUBE SOCKET HARNESS PT. NO. 134-14

Figure 17

Connect the harness leads as follows:

- () Yellow
- () White
- () Gray

- TM4 (S-5)
- TL2 (S-2)
- TL1 (S-1)

The black, yellow-black and green-black (long) leads will be connected later to the filament switch.

() Select the two panel support brackets and install the grommets at GC, GD, GE and GF. See Figures 18 and 19.

Lead Color	Connect to
() Brown	TM1 (S-5)
() Violet	TM7 (S-3)
() Red	TM2 (S-5)
() Yellow-Red	TM9 (S-1)
() Green-Black (3" lead)	TM8 (S-1)
() Blue	TM6 (S-4)
() Orange	TM3 (S-5)
() Green	TM5 (S-5)

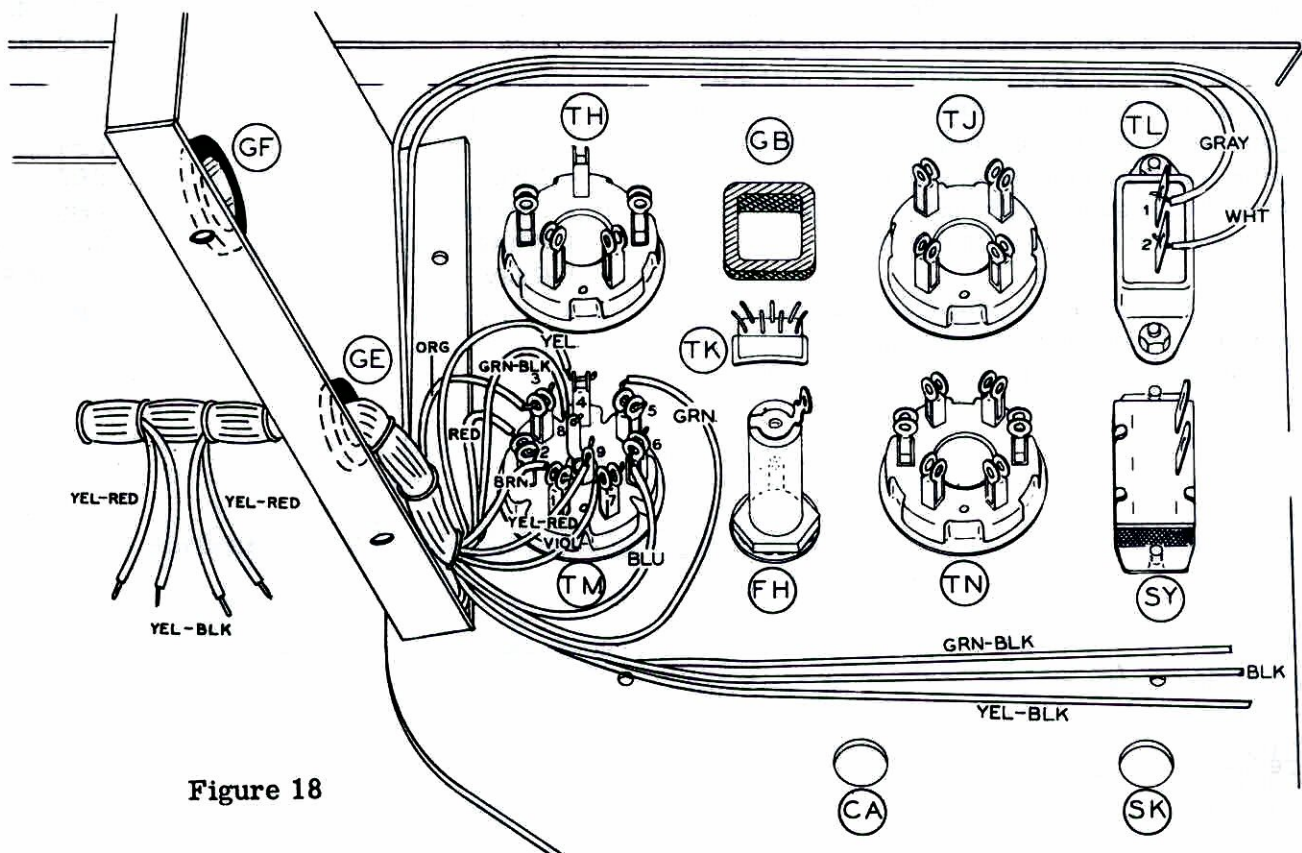

Figure 18

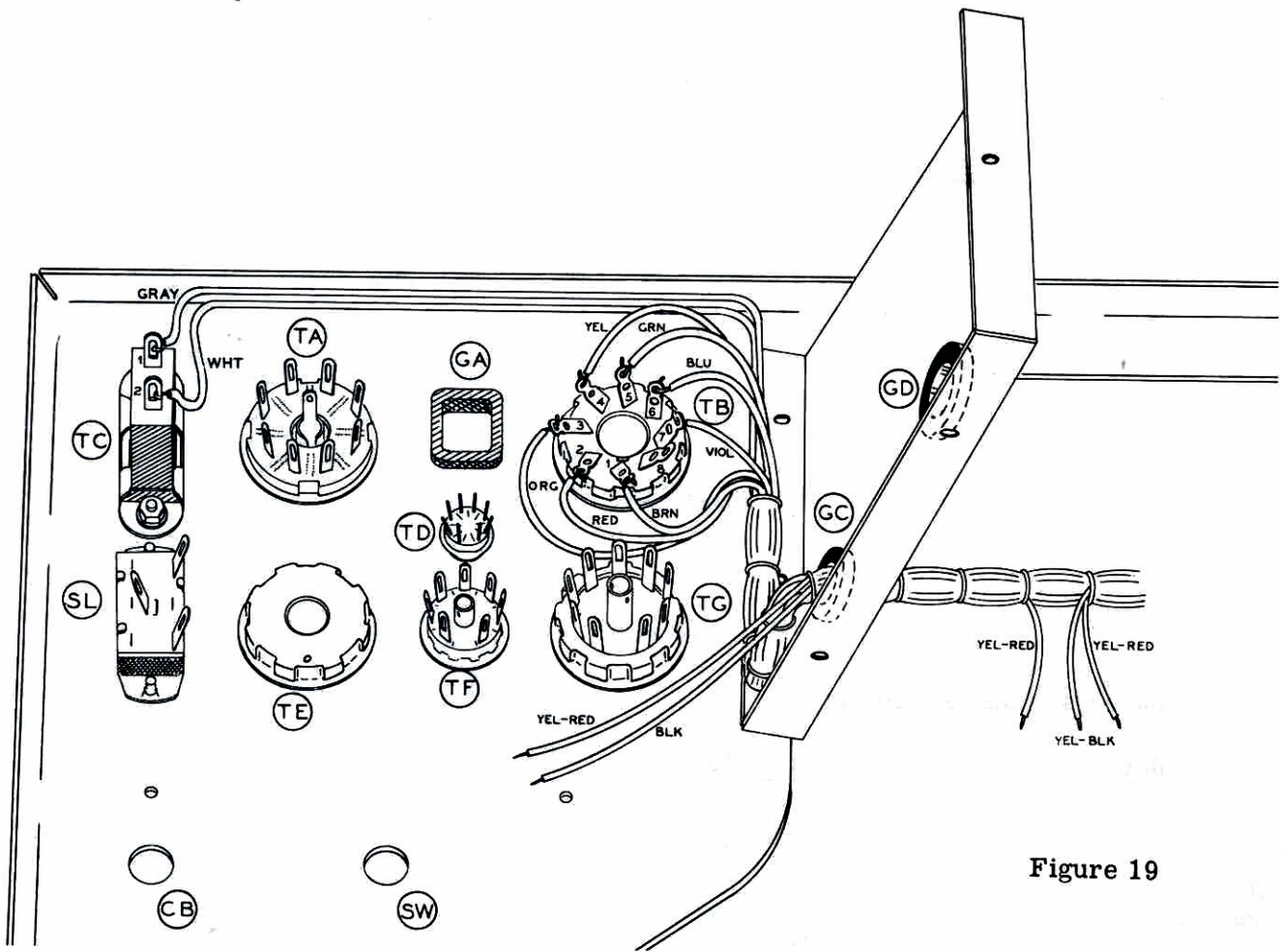

Figure 19

() Slide both brackets onto the cable harness. Make sure the brackets go onto the harness in the proper order. The flanges on the brackets should extend toward the ends of the panel. The front end flange (toward the panel) has two holes which line up with the corresponding holes in the panel. The flange with one hole is to be toward the rear. The long flange on one side of the bracket should be toward the bottom of the panel.

With both brackets properly placed on the harness, (but not attached to the panel), make connections to TB and TC, as follows:

Lead Color

Connect to

() Brown	TB1 (S-3)
() Red	TB2 (S-3)
() Orange	TB3 (S-3)
() Violet	TB7 (S-3)
() Yellow	TB4 (S-3)
() Blue	TB6 (S-3)
() Green	TB5 (S-3)
() White	TC2 (S-1)
() Gray	TC1 (NS)

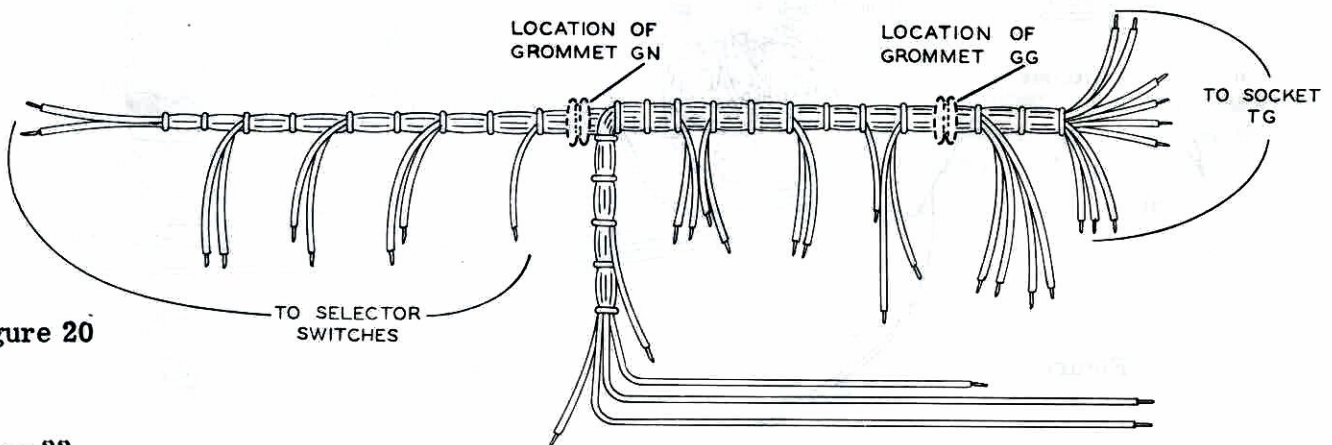

Figure 20

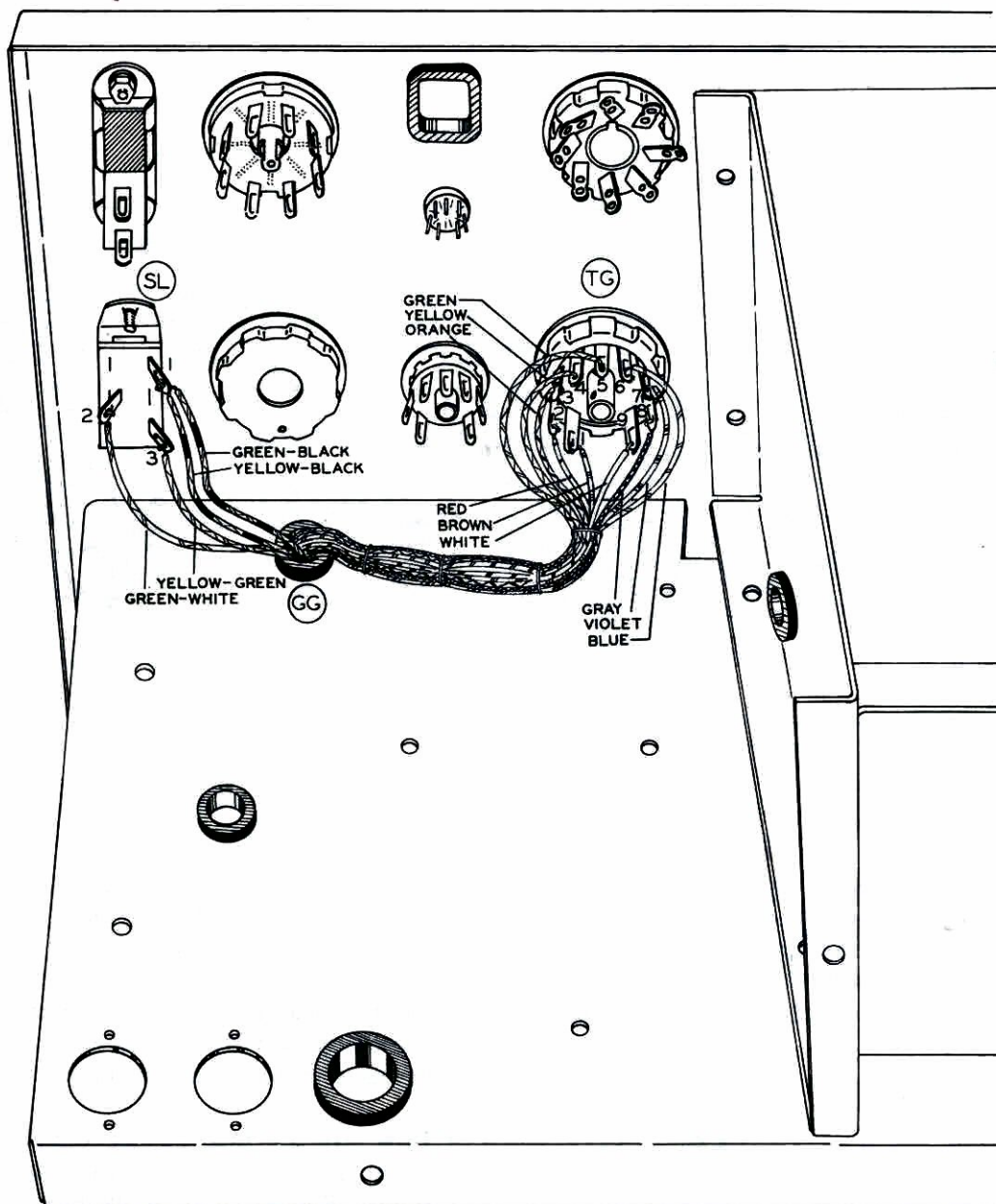

Figure 21

INSTALLATION OF SELECTOR SWITCH TO TUBE SOCKET HARNESS

- () Identify the SELECTOR switch to tube socket cable harness (#134-13) and study carefully its position relative to the panel by reference to Figures 20 and 21. Identify the tube socket end of the cable by reference to Figure 20.
- () Install the grommet GG in the chassis.
- () Starting from the bottom side of the chassis, slide the tube socket end of the SELECTOR switch to tube socket harness through grommet GG. Slide the chassis down onto the harness as necessary to allow working space to make connections to socket TG and switch SL, as shown in Figure 21.

Lead Color

- () Brown
- () White
- () Gray
- () Red
- () Orange
- () Violet
- () Blue
- () Yellow
- () Green
- () Green-black
- () Yellow-black
- () Green-white
- () Yellow-green

Connect to

- TG1 (S-3)
- TG9 (S-2)
- TG8 (S-3)
- TG2 (S-3)
- TG3 (S-3)
- TG7 (S-3)
- TG6 (S-3)
- TG4 (S-3)
- TG5 (S-3)
- SL1 (NS)
- SL1 (S-2)
- SL2 (S-1)
- SL3 (S-1)

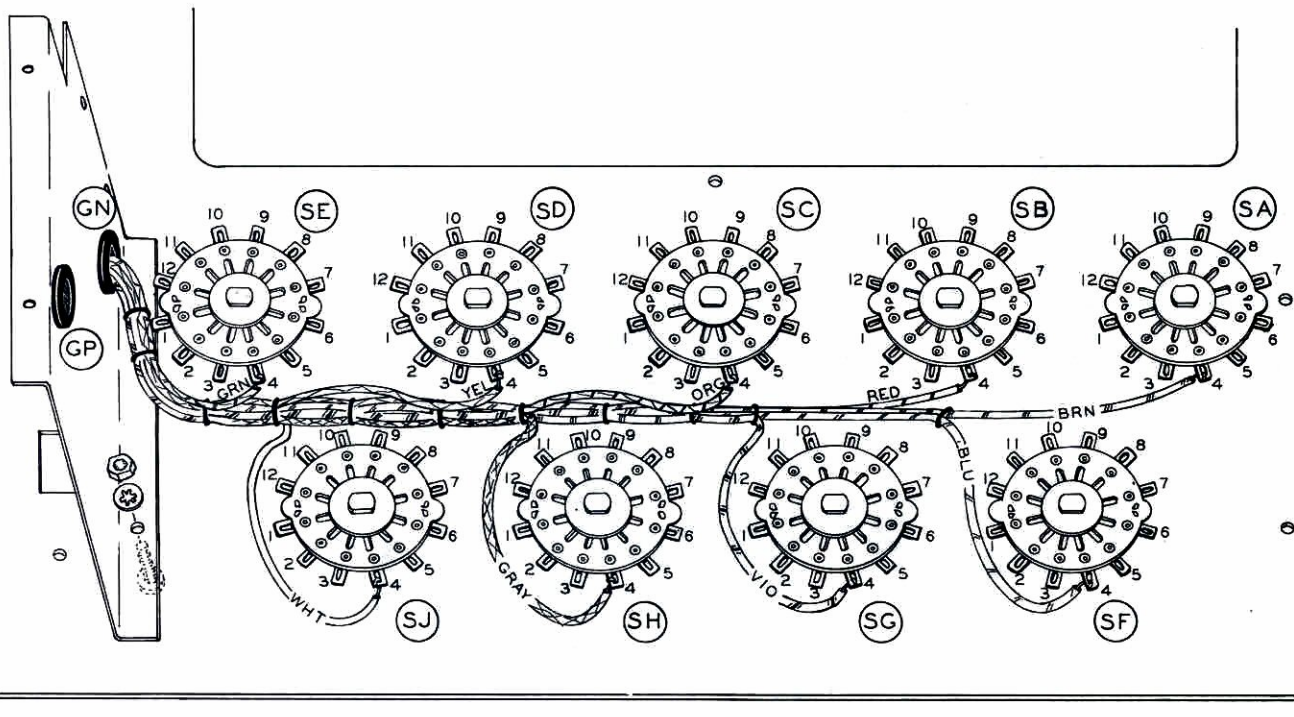

Figure 22

Refer to Figure 22 and install grommets GN and GP in the left hand subchassis support bracket. Secure the bracket to the panel, using 6-32 hardware. Slide the SELECTOR switch end of the cable through GN and connect to the switches, as shown.

<u>Lead Color</u>	<u>Connect to</u>
() Brown	SA4 (S-1)
() Red	SB4 (S-1)
() Orange	SC4 (S-1)
() Yellow	SD4 (S-1)
() Green	SE4 (S-1)
() Blue	SF4 (S-1)
() Violet	SG4 (S-1)
() Gray	SH4 (S-1)
() White	SJ4 (S-1) -S-1

PANEL INSERT (ESCUTCHEON) AND METER INSTALLATION

() Position the HEATHKIT nameplate on the panel insert, as shown. While pressing the nameplate firmly against the mounting surface, heat the two plastic studs extending through the back of the panel insert. The nameplate should be rigidly mounted; if any slippage is noted, reheat the plastic studs to obtain a firm mounting job. ALWAYS maintain the pressure on the front of the nameplate until the melted plastic has solidified.

- () Mount the meter on the meter mounting plate, using the 6-32 nuts provided. Use no lockwasher. See Figure 23.
- () Fasten the two panel support brackets to the chassis with 6-32 hardware. The screw heads should be under the chassis.
- () Now lift the chassis assembly far enough from the panel to slide the panel insert into place. Secure with 6-32 hardware through the hole just above switch SC.
- () Slide the meter and meter mounting plate assembly into place from the top of the panel. Be sure that the meter case seats properly into the panel insert. The TOP edge of the meter case should be in contact with the panel insert.
- () Using the longer 6-32 BHMS, secure the panel support brackets, meter mounting plate and panel insert to the panel. Note that the holes in the meter mounting plate are slightly oversize to allow proper positioning of the meter. If further adjustment is required, loosen the nuts on the four meter mounting studs, adjust meter position, and retighten.
- () Secure the chassis to the panel, using 6-32 hardware.

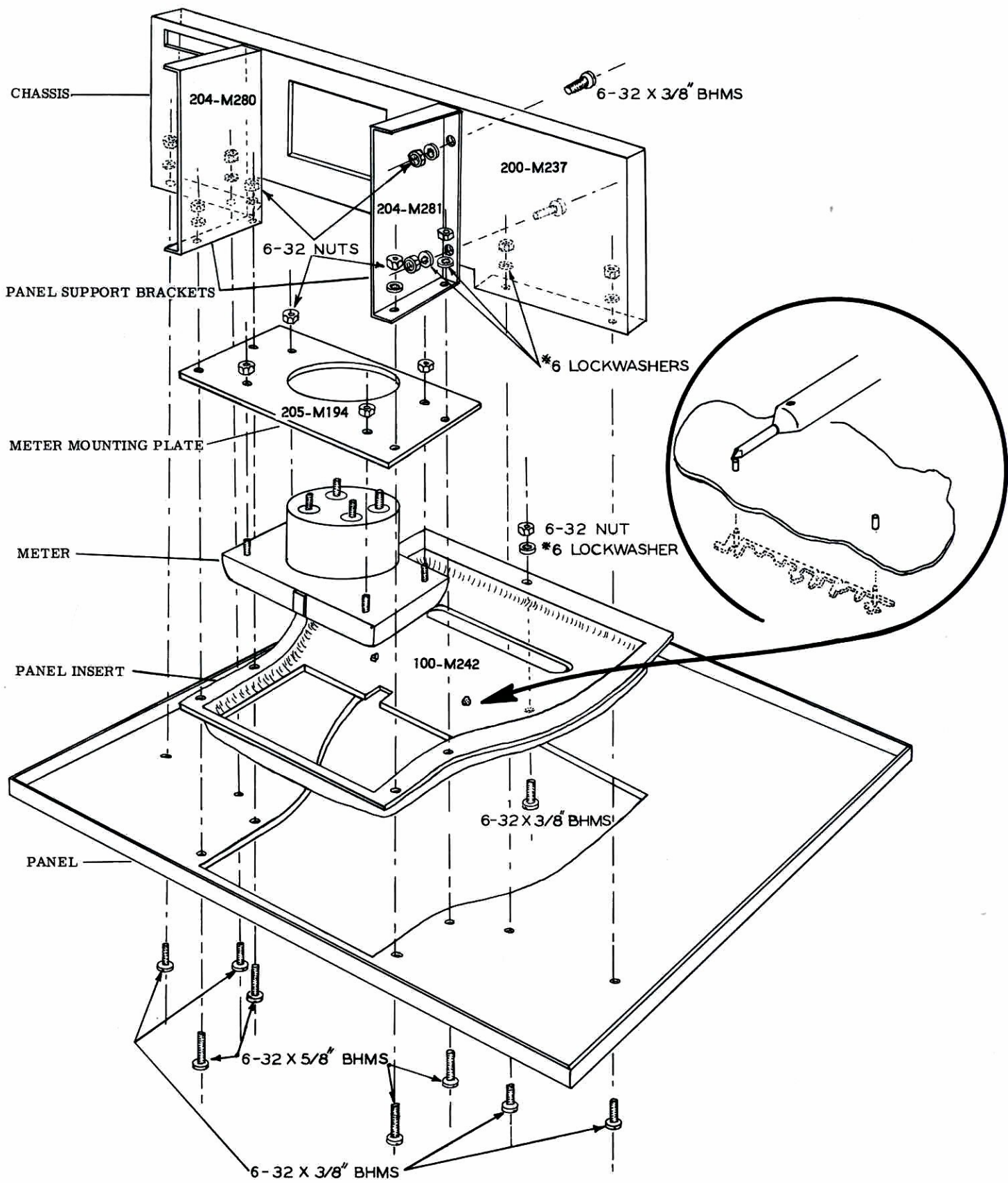

Figure 23

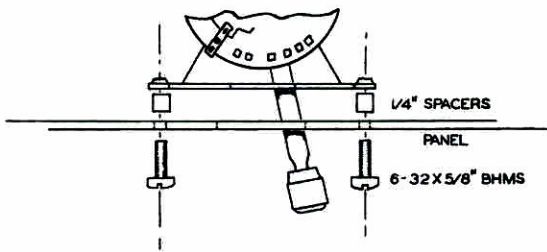

Figure 25

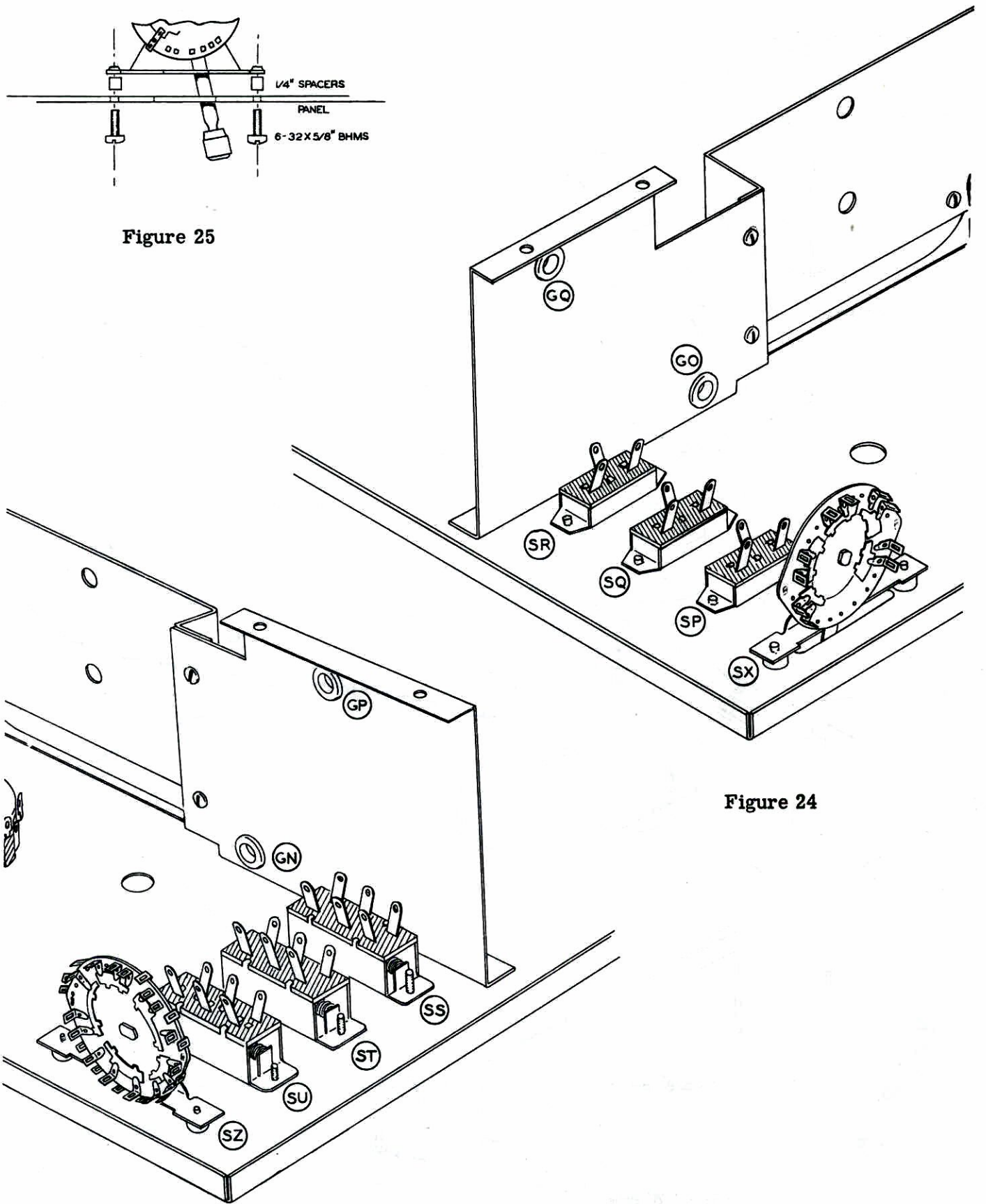

Figure 24

Figure 26

- () Refer to Figure 24 and install grommets GO and GQ in the right hand subchassis support bracket and secure to the panel, using 6-32 hardware.
- () Mount the three SPDT slide switches, SP, SQ and SR. Use 6-32 BHMS.
- () Mount the 5-circuit DISCONNECT lever switch SX (#C-62-12). Use the longer 6-32 BHMS and 1/4" spacers. Center the lever in the slot so that the lever does not come in contact with the panel during operation.
- () Mount the three DPDT spring return slide switches SS, ST and SU. Use 6-32 BHMS.

Note terminal orientation closely. The slide button should be toward the top of the panel.

- () Mount the 9-circuit LIFE test lever switch SZ (#C-62-13). Use the longer BHMS and 1/4" spacers.
- () Assemble the roll chart brackets, as shown in Figure 27. Note that the two panel lamp holes in the panel lamp mounting bracket are not centered in the bracket. Position the bracket in such a way that the panel lamps are closest to the meter. When installing the speednuts, be sure the nut is pushed all the way onto the flange. When correctly positioned, the speednut will drop into place with a "snap".

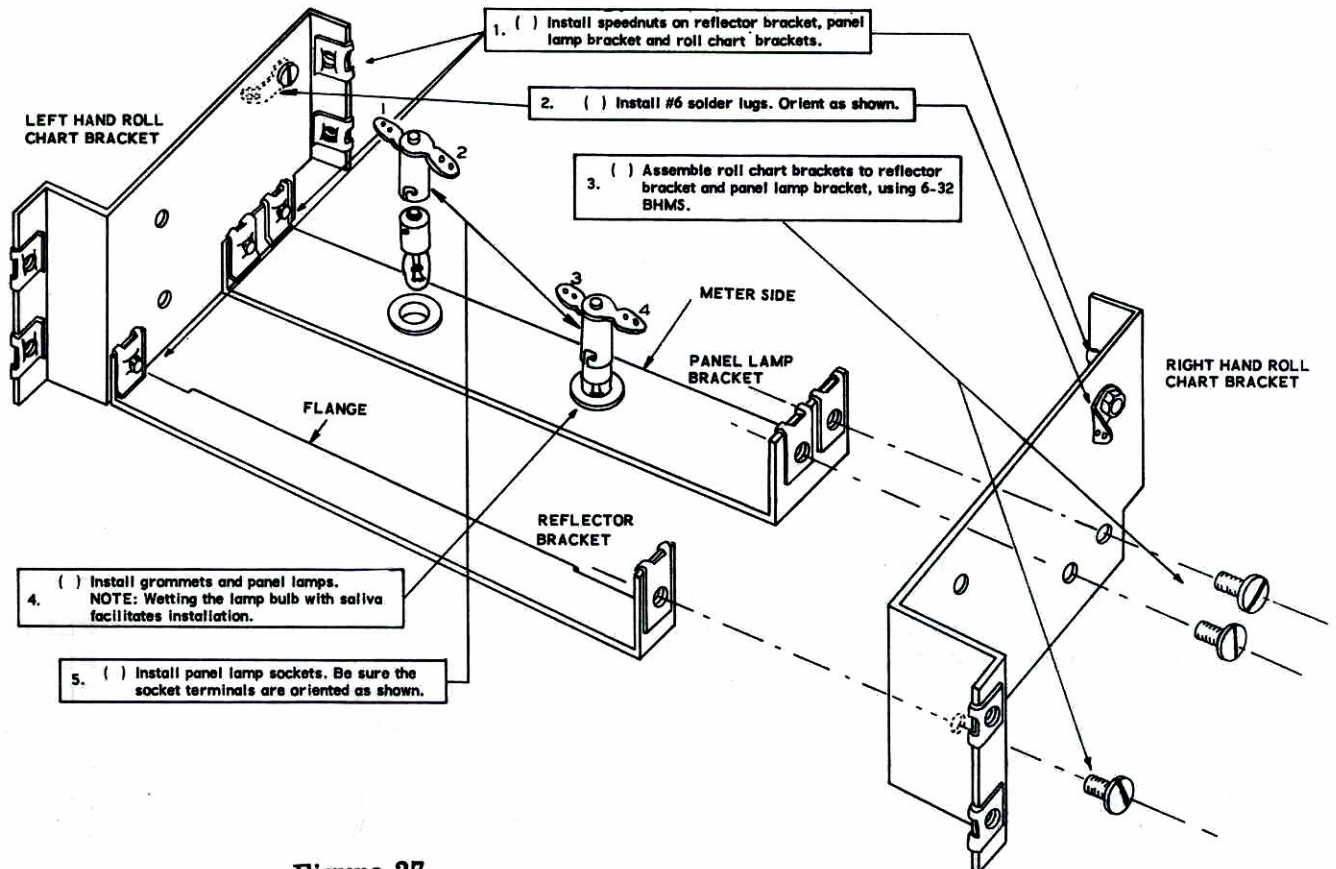

Figure 27

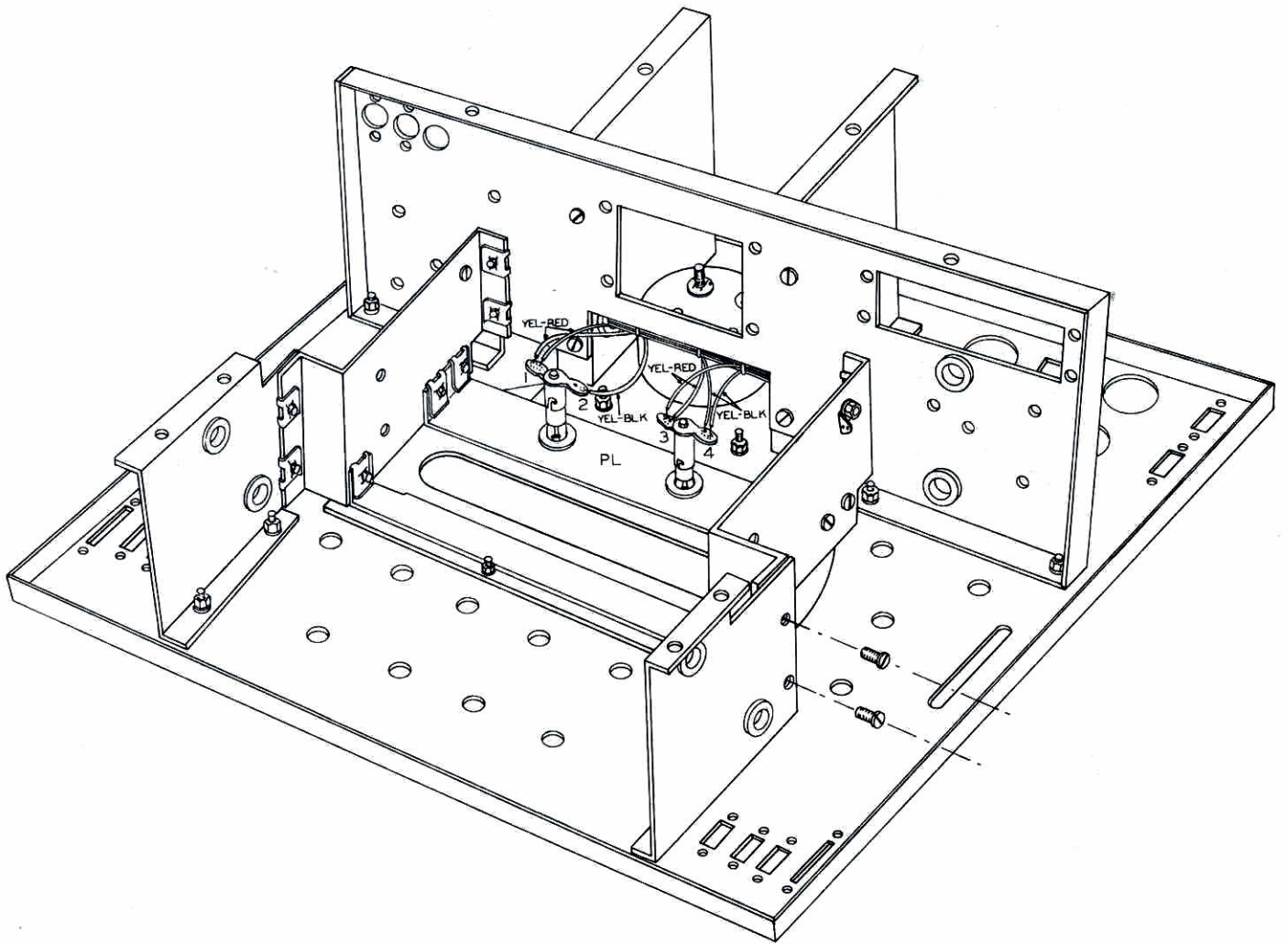

Figure 28

- () Refer to Figure 28 and set the roll chart bracket assembly into place between the subchassis mounting brackets and the chassis. Secure with 6-32 BHMS.

NOTE: It may be necessary to loosen the screws holding the subchassis mounting brackets and chassis assembly to the panel to attain correct alignment of mating holes between these parts and the roll chart brackets.

Connect the leads extending from the tube socket to tube socket cable harness to the panel lamp socket terminals, as shown in Figure 28.

Lead Color

Connect to

- | | |
|------------------|-----------|
| () Yellow-Red | PL1 (NS) |
| () Yellow-Red | PL1 (S-2) |
| () Yellow-Black | PL2 (S-1) |
| () Yellow-Red | PL3 (NS) |
| () Yellow-Red | PL3 (S-2) |
| () Yellow-Black | PL4 (NS) |
| () Yellow-Black | PL4 (S-2) |

- () Push the panel lamp bulbs through the grommets as far as possible without making contact with the panel insert.

*See Book TT-1A
Pg 4
add'l steps*

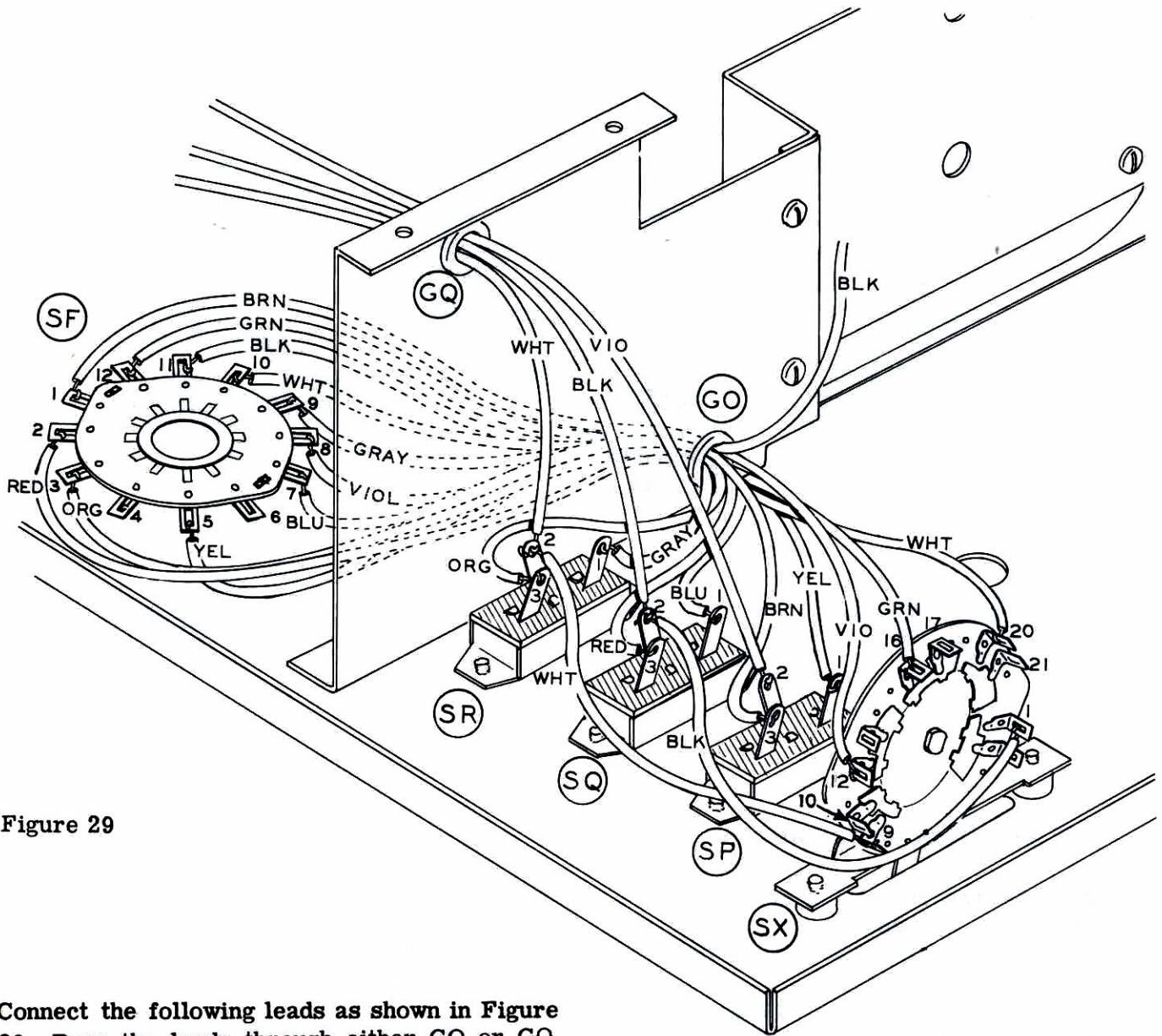

Figure 29

Connect the following leads as shown in Figure 29. Pass the leads through either GO or GQ, as indicated.

<u>Length</u>	<u>Color</u>	<u>From</u>	<u>To</u>
() 11"	Brown	SF1 (S-2)	SP3 (S-1)
() 9 1/2"	Red	SF2 (S-2)	SQ3 (S-1)
() 8"	Orange	SF3 (S-2)	SR3 (S-1)
() 8 1/2"	Yellow	SF5 (S-2)	SP1 (S-1)
() 7 1/2"	Blue	SF7 (S-2)	SQ1 (NS)
() 9 1/2"	Violet	SF8 (S-2)	SX12 (S-1)
() 6 1/2"	Gray	SF9 (S-2)	SR1 (NS)
() 10 1/2"	White	SF10 (S-2)	SX20 (S-1)
() 11"	Black	SF11 (S-2)	Hang free-connect later
() 11 1/2"	Green	SF12 (S-2)	SX16 (S-1)
() 5 1/2"	Black	SQ2 (NS)	SX1 (S-1)
() 6"	White	SR2 (NS)	SX9 (S-1)
() 15"	Black	SQ2 (S-2)	Hang free - connect later
() 15"	White	SR2 (S-2)	Hang free - connect later
() 15"	Violet	SP2 (NS)	Hang free - connect later

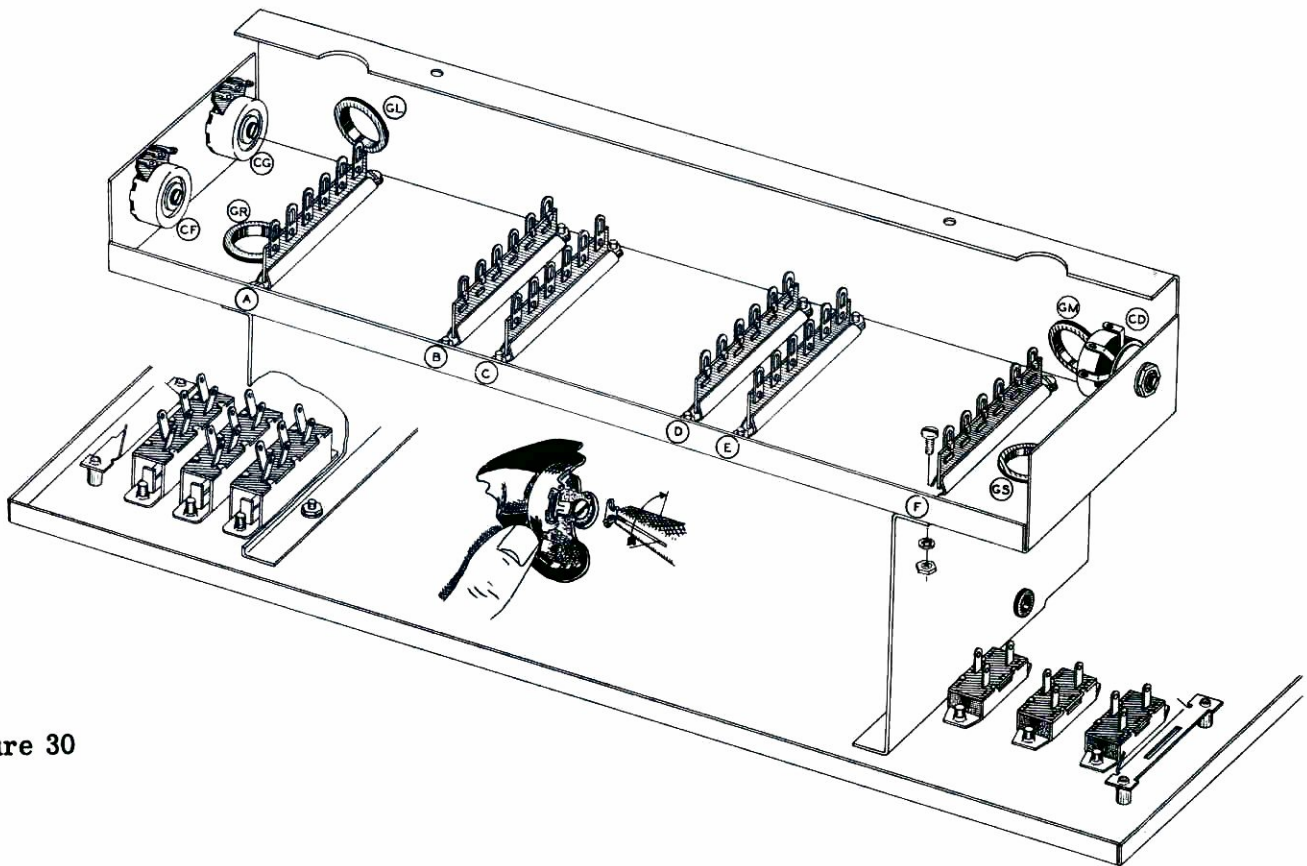

Figure 30

SUB-CHASSIS ASSEMBLY

- () Mount the two 10 K Ω tab mount controls (#10-57) in the end flange of the sub-chassis. See Figure 30 for mounting details.
- () Mount the 10 K Ω wire-wound control (#11-34) in the opposite flange, using a control lockwasher, flat washer and nut. Rotate the control slightly from the perpendicular so that the #1 terminal is not hidden under the rear mounting flange. Bend terminals as shown.
- () Install grommets GL, GM, GR and GS.
- () Mount terminal strips B, C, D and E, using 6-32 hardware. Lockwashers between terminal strip and chassis are not required.
- () Mount the subchassis on the subchassis support brackets, at the same time mounting terminal strips A and F.
- () Mount the BIAS control CB (#11-35).
- () Mount the 7.5 K Ω METER control CC (#11-36). Push the cable harness toward the center of the panel to allow clearance for the control. Carefully bend the control terminals toward the back of the control.
- () Connect resistors to the SIGNAL switch (#63-220) as follows: (See Figure 31.)
- () Connect a 250 Ω 1% resistor from SO10 (NS) to SO12 (NS).
- () Connect a 250 Ω 1% resistor from SO12 (S-2) to SO3 (NS).
- () Connect a 500 Ω 1% resistor from SO3 (S-2) to SO6 (NS).
- () Connect a 1 K Ω 1% resistor from SO6 (S-2) to SO1 (NS).
- () Connect a 4.7 K Ω resistor (yellow-violet-red) from SO1 (S-2) to SO8 (NS).
- () Mount the SIGNAL switch SO as shown in Figure 32, using control hardware.

SUBASSEMBLY OF SIGNAL SWITCH

Connect resistors to the SIGNAL switch (#63-

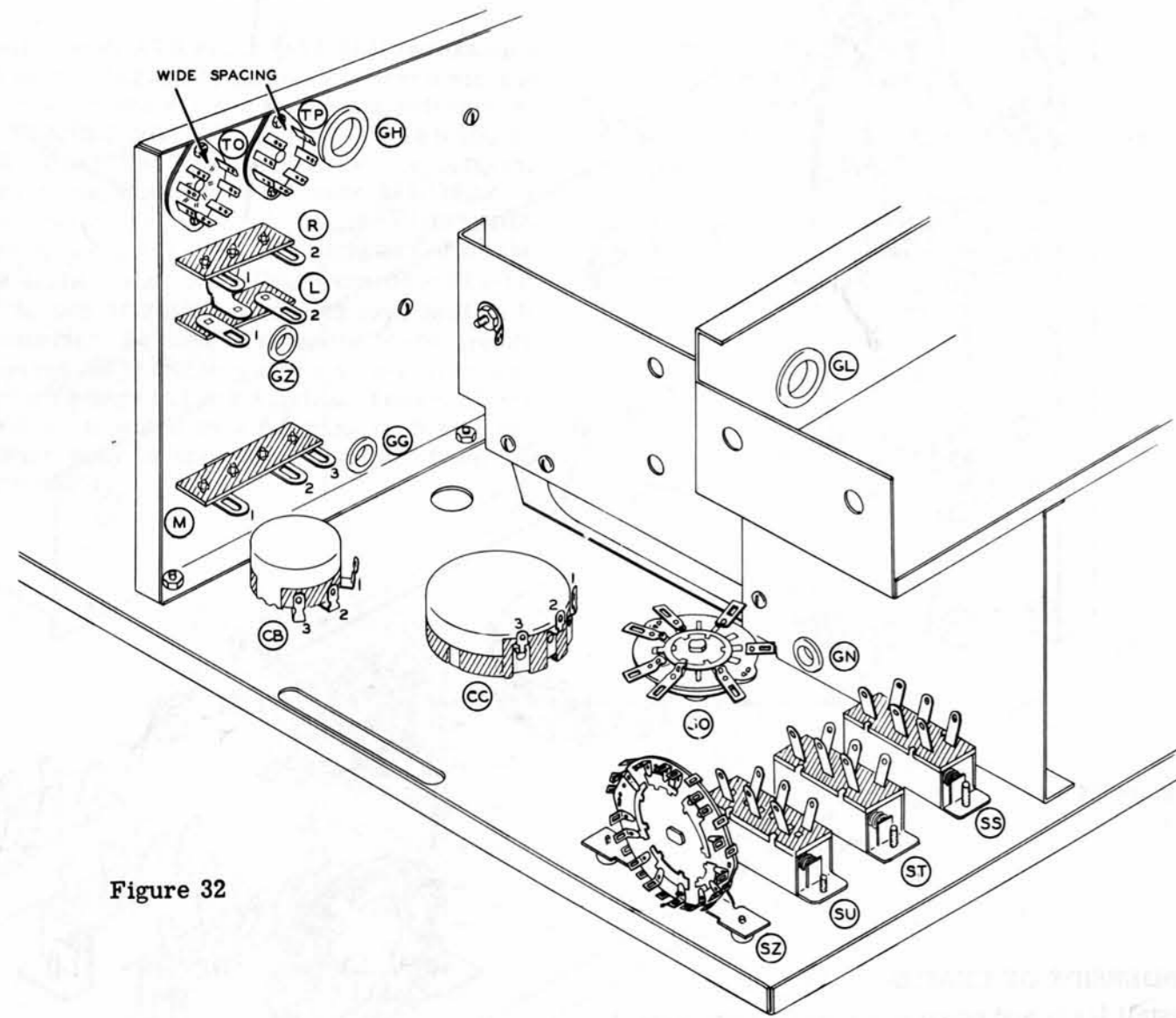

Figure 32

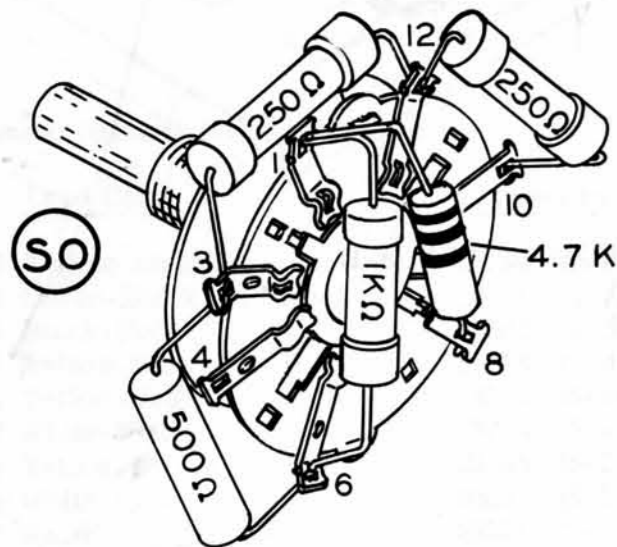
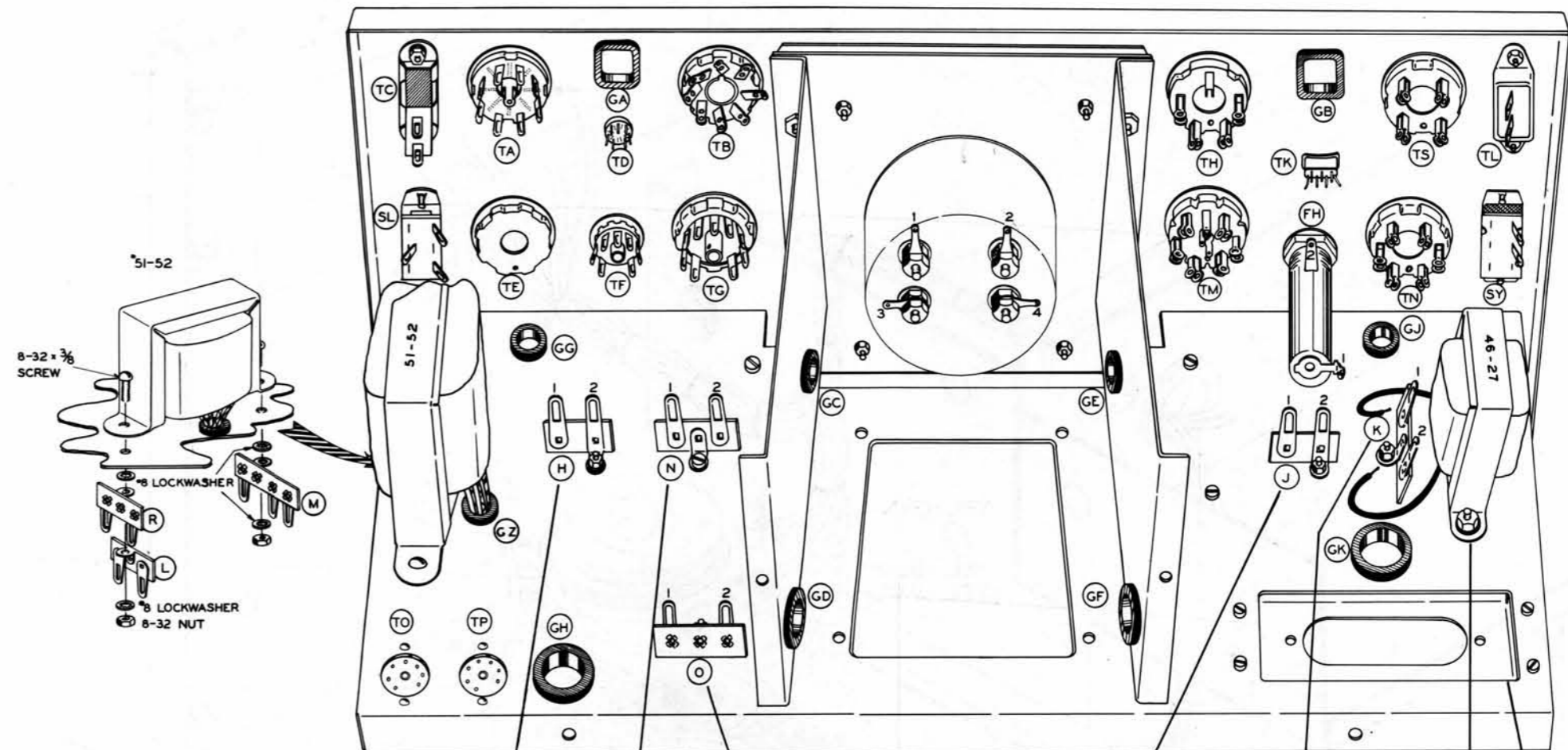

Figure 31

CHASSIS MOUNTED COMPONENTS

Follow the steps outlined in Figure 33 for the mounting of those parts located on the chassis. Also, refer to Figure 32.

- () Install grommets GZ, GH, GJ and GK.
- () Mount the oscillator transformer (#51-52), using 8-32 hardware. Terminal strips L, M and R are mounted at the same time. Observe terminal orientation. The mounting holes in these three terminal strips are larger than the others to accommodate the #8 screw.
- () Mount the two 7-pin wafer sockets TO and TP, using 3-48 hardware.



- 1 () Mount 2-lug terminal strip H. Use 6-32 hardware.
- 2 () Mount 2-lug terminal strip N. Use screw holding roll chart bracket.
- 3 () Mount 2-lug terminal strip O. Use 6-32 hardware.
- 4 () Mount 2-lug terminal strip J. Use 6-32 hardware.
- 5 () Mount 2-lug terminal strip K. Use 6-32 hardware.
- 6 () Mount the choke coil (#46-27), using 8-32 hardware. BE SURE the screw heads are underneath the chassis.
- 7 () Install the capacitor mounting bracket, using 6-32 hardware.

Figure 33

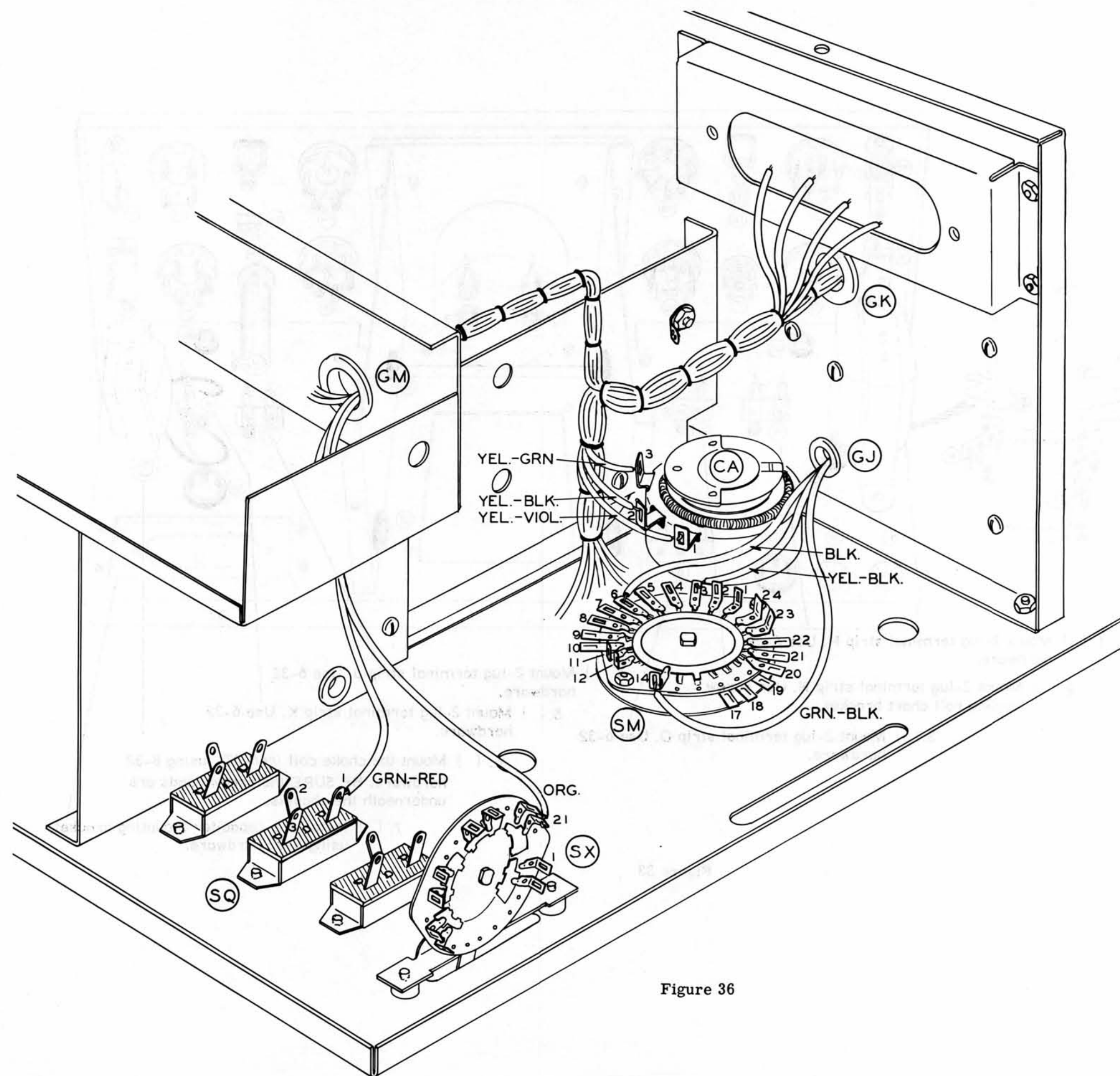

Figure 36

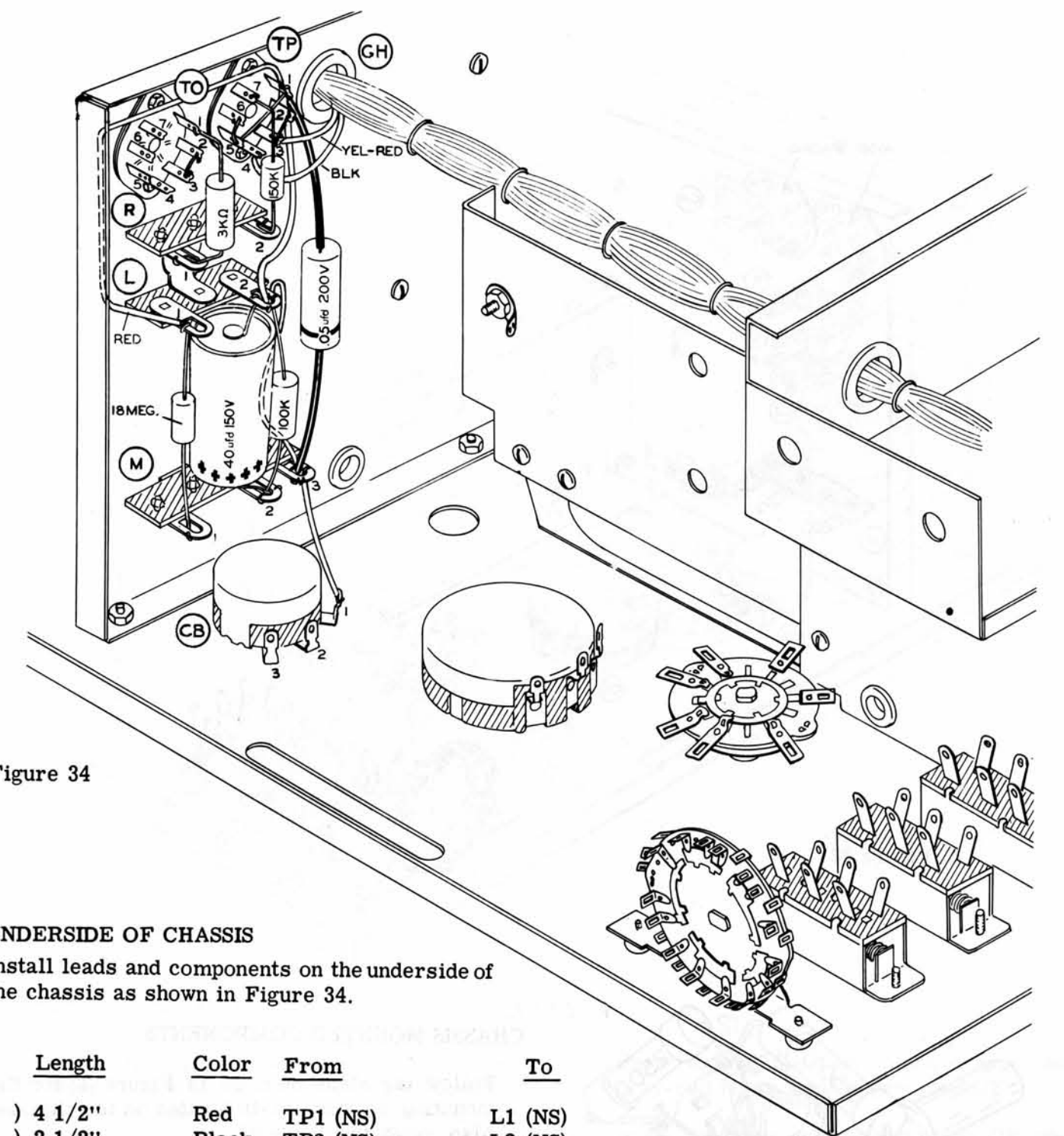

Figure 34

UNDERSIDE OF CHASSIS

Install leads and components on the underside of the chassis as shown in Figure 34.

Length	Color	From	To
() 4 1/2"	Red	TP1 (NS)	L1 (NS)
() 2 1/2"	Black	TP2 (NS)	L2 (NS)
() 3 1/2"	Black	L2 (NS)	M3 (NS)
() Bare Jumper		TP1 (NS)	through TP5 (S-1) to TP6 (S-1)
() Bare Jumper		TP2 (S-2)	TP3 (NS)
() Bare Jumper		TO2 (S-1)	TO3 (NS)
() 3"	Black	M3 (NS)	CB1 (NS)

- () Pass the two leads from the tube socket to tube socket harness through grommet GH.
- () Connect the black lead to TP4 (S-1).
- () Connect the yellow-red lead to TP3 (NS).

	<u>From</u>	<u>To</u>
() 40 μ fd 150 V capacitor	L2 (NS)	M2 (NS) (Neg to L2)
() 3 K Ω 5% 1 W resistor (orange-black-red)	R1 (NS)	TO1 (NS)
() 150 K Ω resistor (brown-green-yellow)	TP7 (S-1)	R2 (NS)
() .05 μ fd 200 V capacitor	TP1 (S-3)	M3 (NS) (Use sleeving)
() 18 megohm resistor (brown-gray-blue)	L1 (NS)	M1 (NS)
() 100 K Ω 1 W resistor (brown-black-yellow)	L2 (S-4)	M2 (NS)

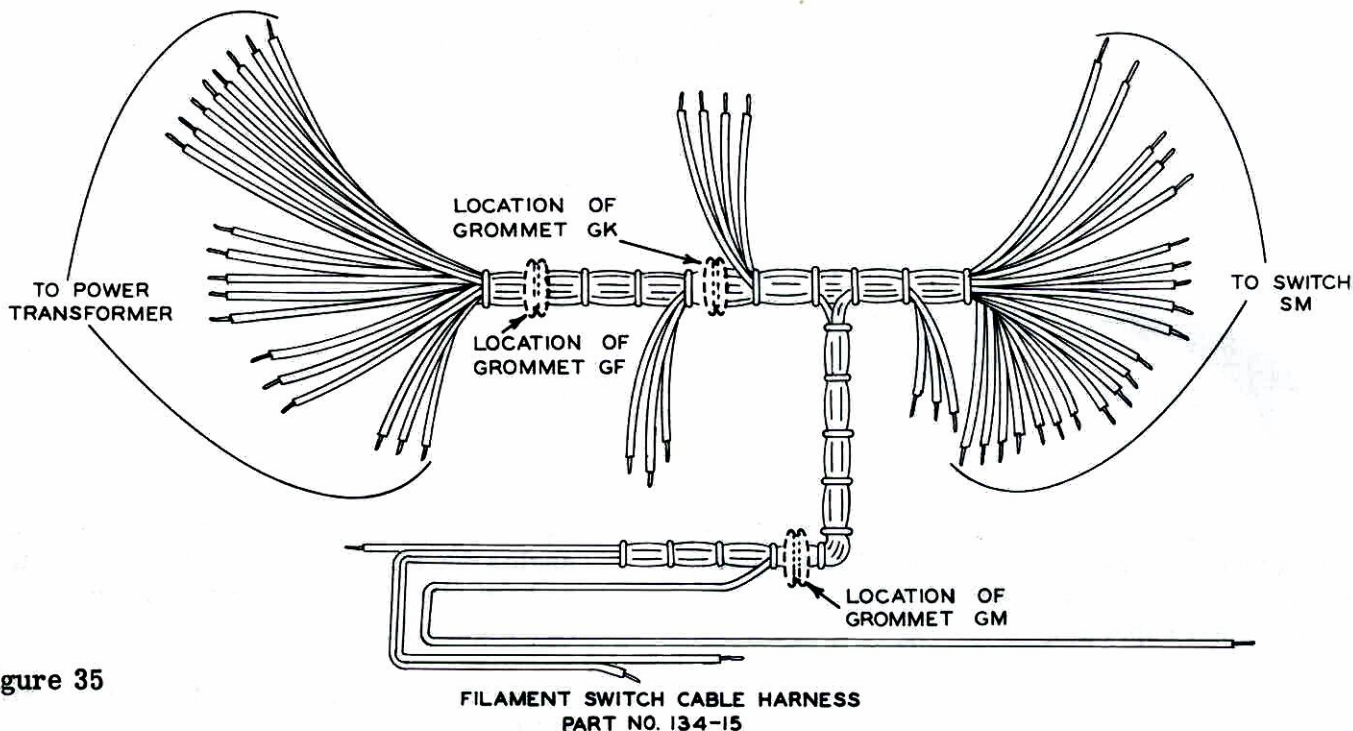

Figure 35

INSTALLATION OF FILAMENT SWITCH AND FILAMENT SWITCH CABLE HARNESS

- () Mount the FILAMENT switch (#63-221) with terminal orientation as shown in Figure 36. Terminals 1 and 24 should be toward the top of the panel (nearest chassis). Installation of the knob will indicate the exact orientation of the switch, since the flat on the shaft determines the location of the knob position with respect to the screening on the panel.
- () Pass the black, yellow-black and green-black wires from the tube socket harness through GJ and connect to the FILAMENT switch, as shown in Figure 36 (on fold-out page).

- | <u>Lead Color</u> | <u>Connect to</u> |
|-------------------|-------------------|
| () Yellow-Black | SM3 (NS) |
| () Green-Black | SM14 (NS) |
| () Black | SM6 (NS) |
- () Identify the FILAMENT switch cable harness (#134-15). Bend the entire cable at a right angle at the switch breakout. See Figure 36. Start both ends of the cable through the proper grommets, GM and GK. Bring the switch breakout portion of the cable down to the panel between the switch and the roll chart bracket. Be sure to leave room for the SET LINE control to be mounted later. Connect the harness leads to the switch, as shown in Figures 36 and 37.

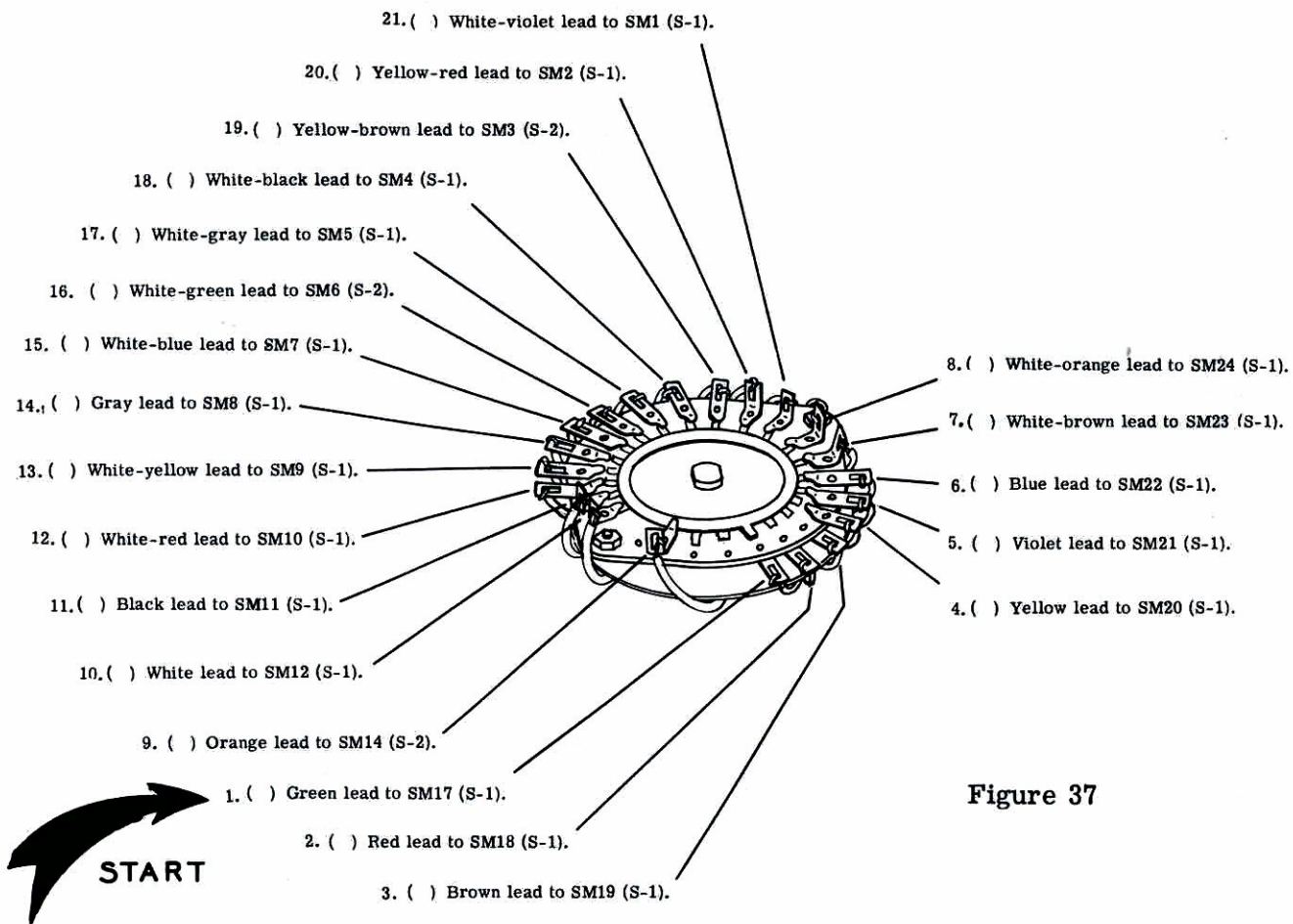

Figure 37

The four leads which break out of the harness just before it passes through GK (brown, red, green and green-brown) will be connected later to the ballast capacitor.

() Mount the SET LINE control CA (350 Ω 25 watt wire-wound, #11-37). CAREFULLY bend the lugs as shown in Figure 36 so they will not interfere with the cable harness or come into contact with the roll chart bracket.

Connect the yellow-green, yellow-violet and yellow-black leads which break out of the harness just above the FILAMENT switch to control CA. See Figure 36.

<u>Lead Color</u>	<u>Connect to</u>
() Yellow-Green	CA3 (S-1)
() Yellow-Black	CA2 (S-1)
() Yellow-Violet	CA1 (S-1)

() Dress the leads between the FILAMENT switch and SET LINE control toward the switch so that NONE of the leads come in contact with the control.

() Above the chassis, bend the cable at right angles as shown and pass the transformer end of the cable through grommet GF. See Figure 38.

() Connect lead number 8 of the P.E.C. (#84-18) to J2 (S-1).

() Connect the two choke leads to K1 (NS) and K2 (NS).

() Connect the green-red lead to J1 (NS).

() Connect the green-black lead to K2 (S-2).

() Connect the yellow-black lead to FH1 (S-1).

() On the subchassis, pass all leads, except green-black, through GS. Connect the green-black lead to C5 (NS). See Figure 39.

() Connect the green-red lead to SQ1 (S-2).

() Connect the green-brown lead to SZ25 (S-1). See Figure 52. Pass the lead through GQ and GP.

() Connect the orange lead to SX21 (NS). See Figure 36 for terminal location.

Connections to the power transformer and ballast capacitor will be made later.

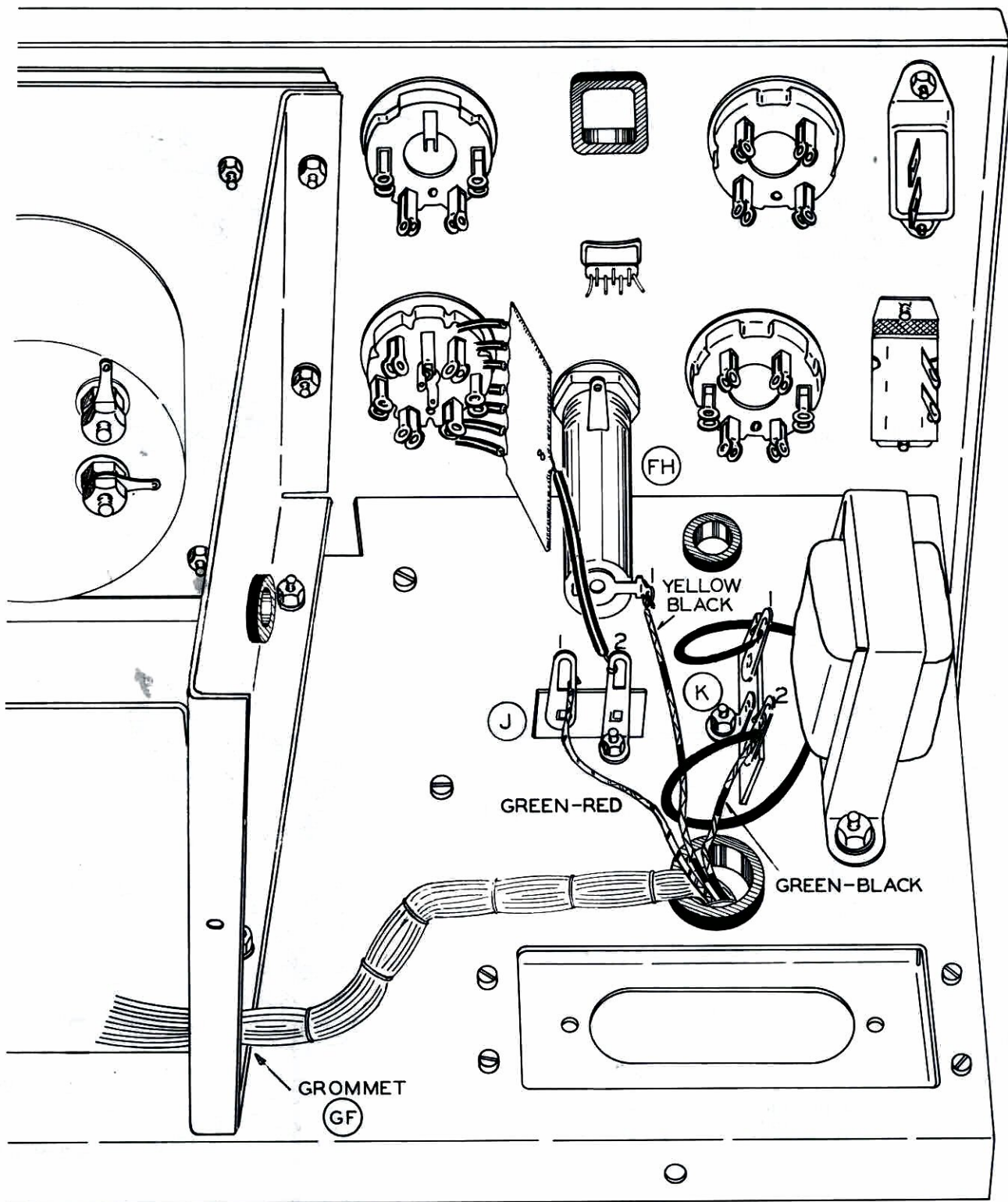

Figure 38

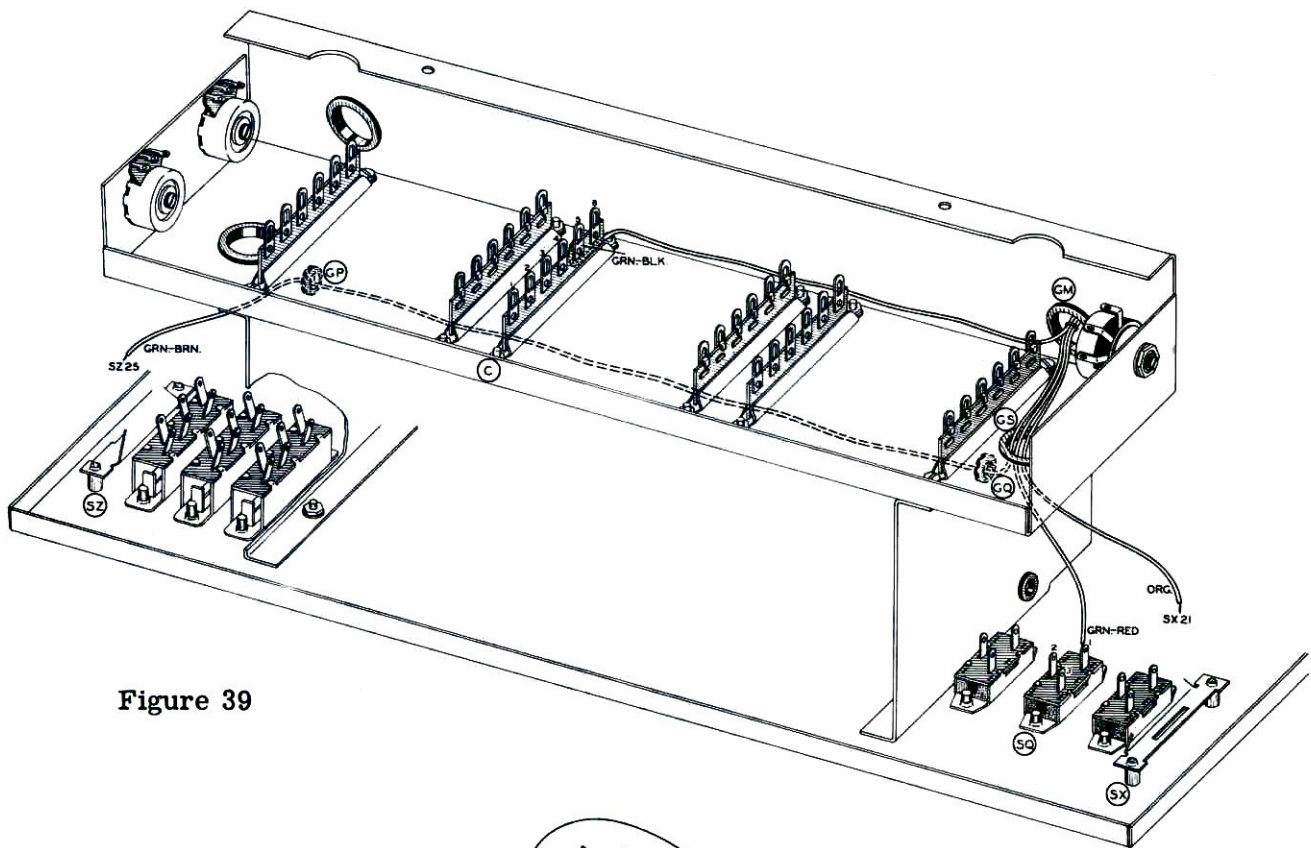

Figure 39

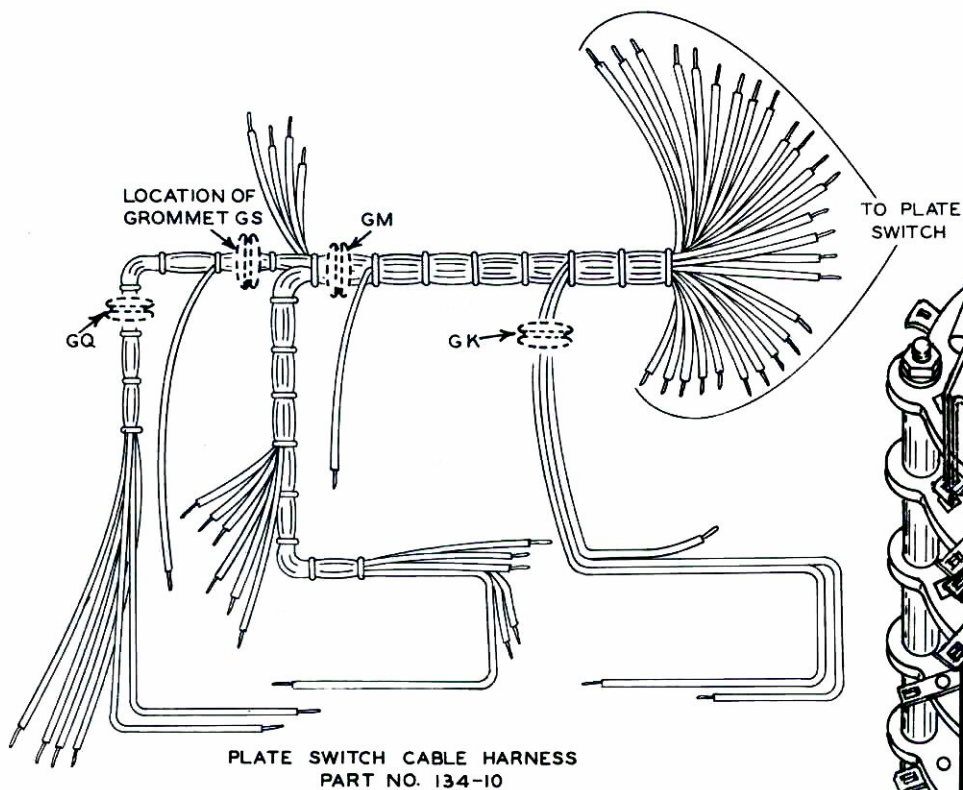

Figure 40

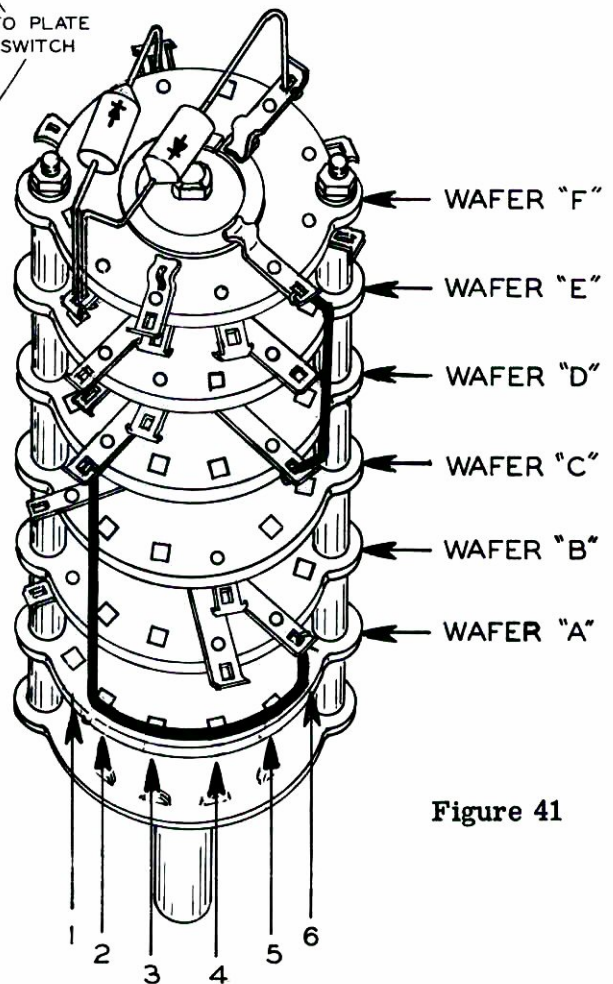

Figure 41

PLATE SWITCH SUBASSEMBLY

Identify the PLATE switch (#63-218) and examine it closely. Thoroughly acquaint yourself with the placement of the various terminals, referring to the NUMBERING SYSTEM AND ALPHABETICAL DESIGNATION section of the General Instructions, if necessary. Figure 42 illustrates the steps involved in connecting the Plate switch harness (#134-10). Lay the harness flat on the work surface and connect the leads to the PLATE switch, one at a time, soldering each lead as it is connected. Be sure to move the leads already connected out of the way of the soldering iron to prevent damage to the insulation. The rectifiers should be mounted in a position such that the rectifier body is approximately 1/4" from the switch wafer.

- () Connect a 2 1/2" black wire from SKD2 (NS) to SKB5 (S-1).
- () Connect a 1 1/2" black wire from SKD5 (S-1) to SKF5 (NS).
- () Connect a silicon diode from SKF2 (NS) to SKF10 (S-1). The (+) end of the diode is connected to SKF10.
- () Connect a silicon diode from SKF2 (S-2) to SKF8 (S-1). The (+) end of the diode is connected to SKF2.

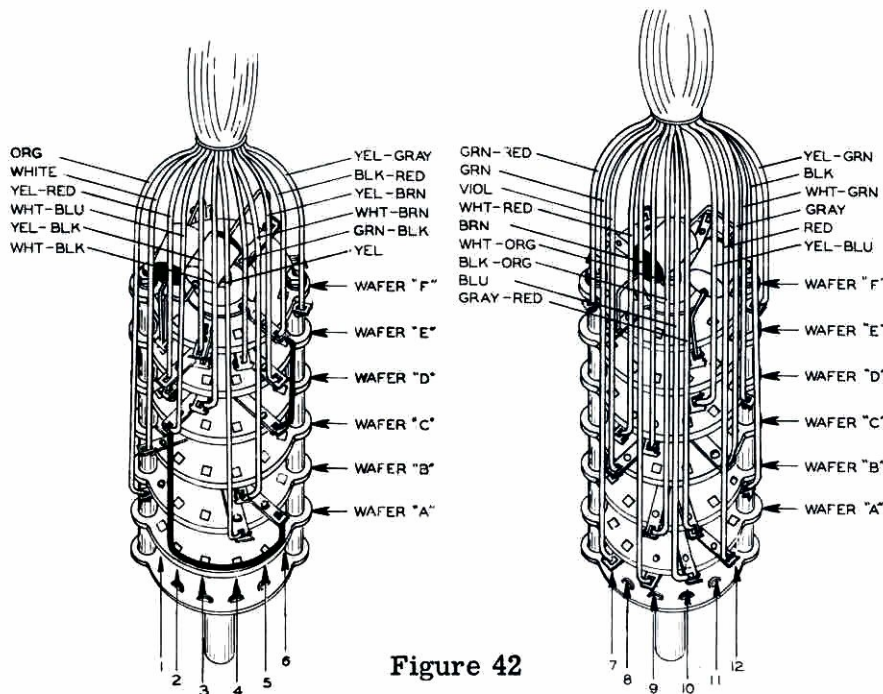

Figure 42

Connect harness leads as follows:

<u>Lead Color</u>	<u>Connect to</u>
() Yellow-Black	SKF3 (S-1)
() Green-Black	SKF4 (S-1)
() Black-Red	SKF5 (S-2)
() Yellow-Gray	SKF6 (S-1)
() Yellow-Red	SKE2 (S-1)
() White-Black	SKE3 (S-1)
() Yellow-Brown	SKE5 (S-1)
() White-Blue	SKD2 (S-2)
() White	SKC1 (S-1)
() White-Brown	SKC4 (S-1)
() Orange	SKB1 (S-1)
() Yellow	SKB4 (S-1)

<u>Lead Color</u>	<u>Connect to</u>
() Green-Red	SKF7 (S-1)
() Yellow-Green	SKF12 (S-1)
() Yellow-Blue	SKE10 (S-1)
() White-Red	SKD8 (S-1)
() White-Orange	SKD9 (S-1)
() White-Green	SKD12 (S-1)
() Violet	SKC8 (S-1)
() Gray	SKC11 (S-1)
() Black-Orange	SKB9 (S-1)
() Gray-Red	SKB10 (S-1)
() Black	SKB12 (S-1)
() Green	SKA8 (S-1)
() Brown	SKA9 (S-1)
() Blue	SKA10 (S-1)
() Red	SKA11 (S-1)

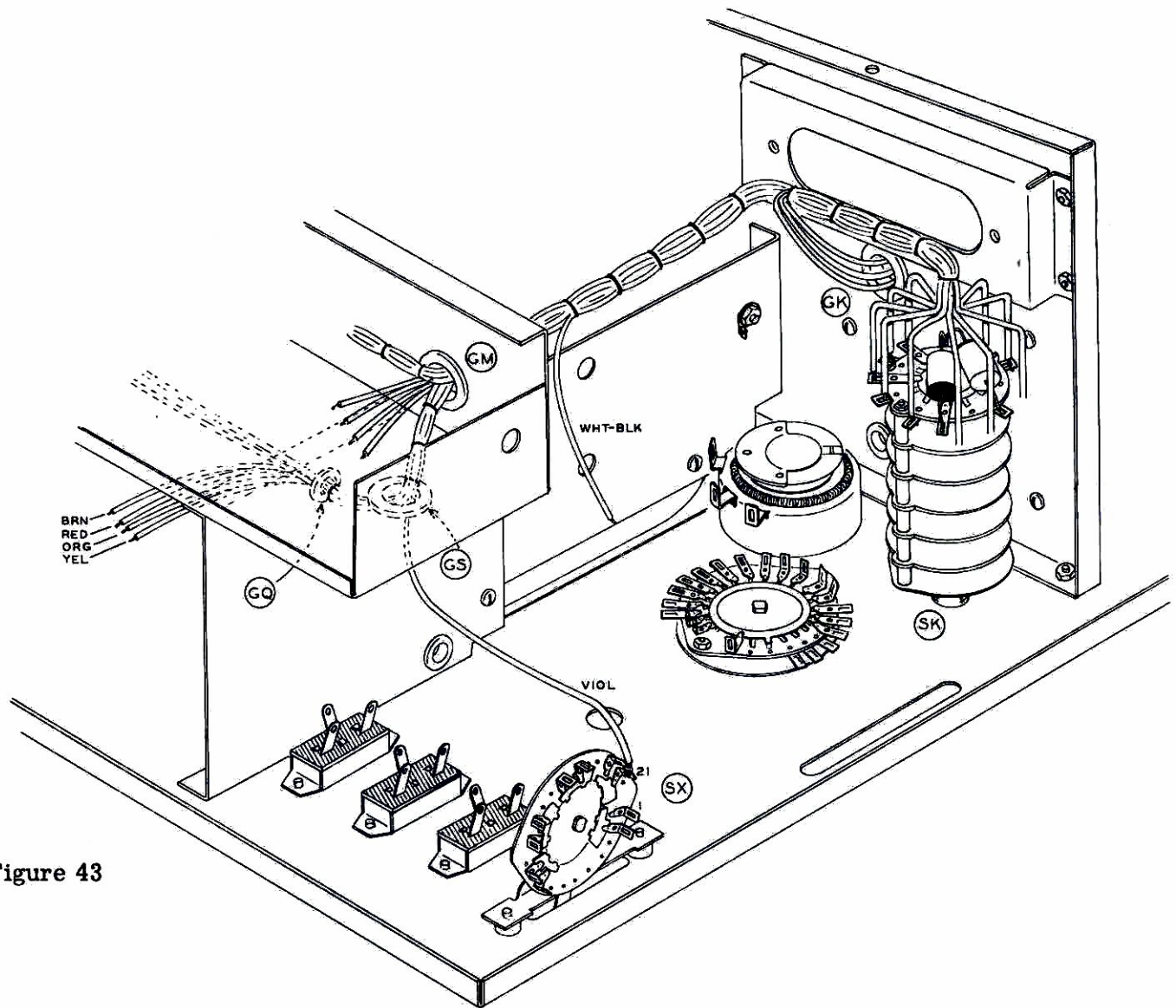

Figure 43

INSTALLATION OF PLATE SWITCH SUB-ASSEMBLY

- () Install the PLATE switch sub-assembly by starting the large group of leads through grommet GM in the sub-chassis flange. The leads attached to the switch should be "squared away" from the switch to provide clearance between each other and the switch frame. Orient the switch so that the #1 terminals are toward the top of the panel (closest to chassis).
- () When the switch has been securely mounted, bend the cable harness above the switch at right angles so that it will assume the position shown in Figure 43. The white-black lead which breaks out of the harness above hole SN will be connected later to the LEAK-AGE switch.
- () Pass the yellow-red, black-orange and gray-red leads through grommet GK.
- () Pass the gray-red lead through GF (See Figure 45) and the mounting hole on the rear flange of the right hand panel support bracket. This lead will be connected later to the power transformer.
- () Pass the black-orange lead through GE and GC and connect it to N2 (NS). See Figures 45 and 53.
- () Connect the yellow-red lead to K1 (S-2). See Figure 45.

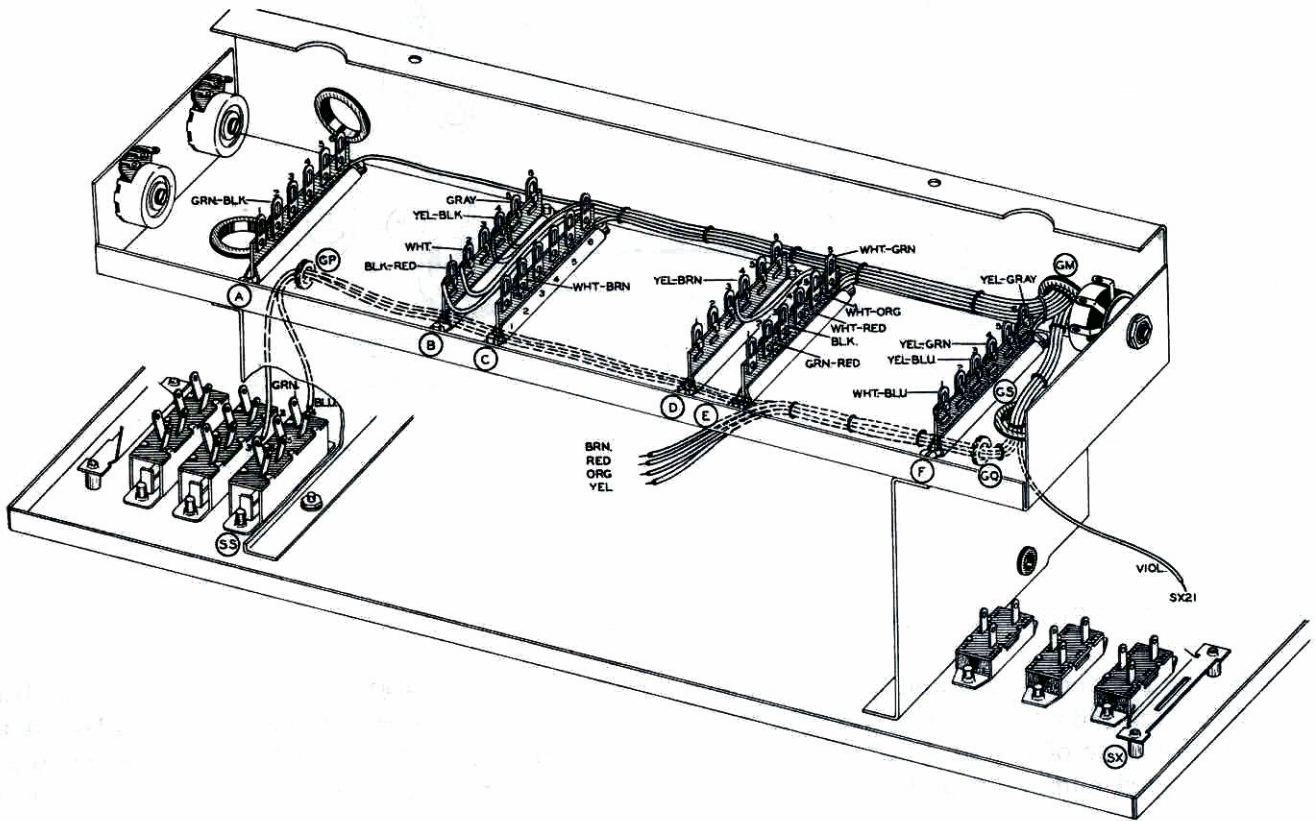
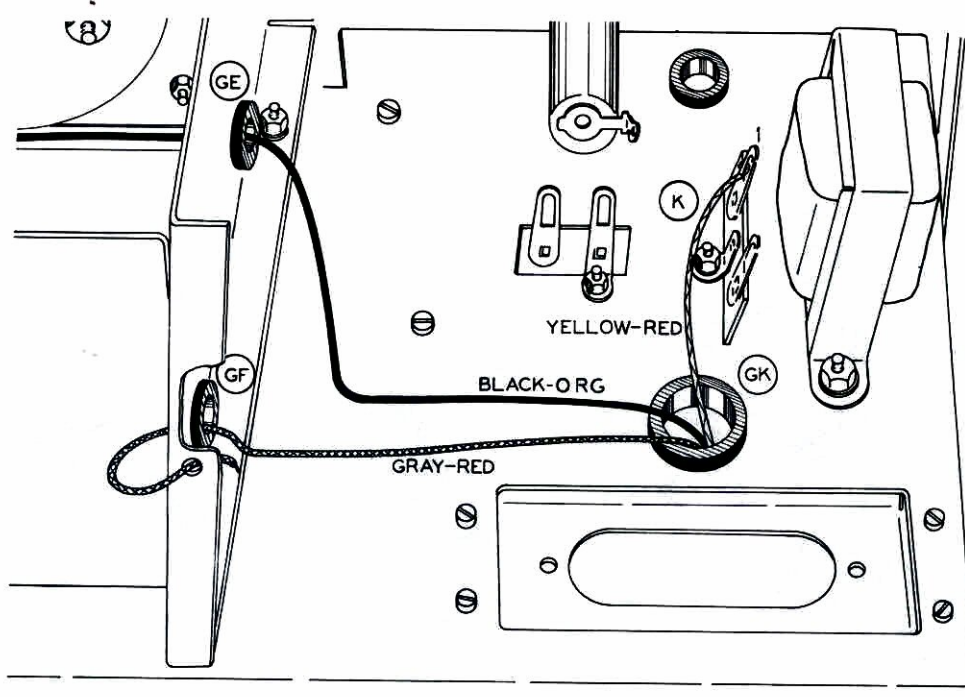

Figure 44

Connect the PLATE switch harness leads on the sub-chassis as follows:

<u>Lead Color</u>	<u>Connect to</u>	
() Yellow-Gray	F6 (NS)	() Pass the violet, green, blue, red, brown, orange and yellow leads through grommet GS.
() Yellow-Green	F4 (NS)	
() Yellow-Blue	F3 (NS)	() Connect the violet lead to SX21 (S-2). See Figure 43.
() White-Blue	F1 (NS)	
() White-Green	E6 (NS)	() Pass the remaining leads through GQ. The brown, red, orange and yellow leads will be connected later to the CALIBRATE switch.
() White-Orange	E5 (NS)	
() White-Red	E4 (NS)	() Pass the blue and green leads through GP.
() Black	E3 (NS)	
() Green-Red	E2 (NS)	() Connect the blue lead to SS4 (S-1) and the green lead to SS3 (S-1).
() Yellow-Brown	D4 (NS)	
() White-Brown	C2 (NS)	
() Gray	B5 (NS)	
() Yellow-Black	B4 (NS)	
() White	B2 (NS)	
() Black-Red	B1 (NS)	
() Green-Black	A2 (NS)	



LEAKAGE SWITCH SUB-ASSEMBLY

Figure 45

The procedure for connecting and installing the LEAKAGE switch (#63-219) is the same as that followed in the case of the PLATE switch. The cable harness part number is 134-11.

() Strip a 7" length of yellow hookup wire to provide the bare wire necessary to make jumper connections on the LEAKAGE switch.

() Connect the #1 terminals on wafers A, B and C with a length of bare wire. Solder A1 and B1. DO NOT solder C1. Be sure a good solder connection is made to both lugs on each wafer.

() Connect a bare jumper from SNA4 (S-1) to SNB6 (NS).

() Connect a bare jumper from SNC4 (S-1) to SND5 (NS).

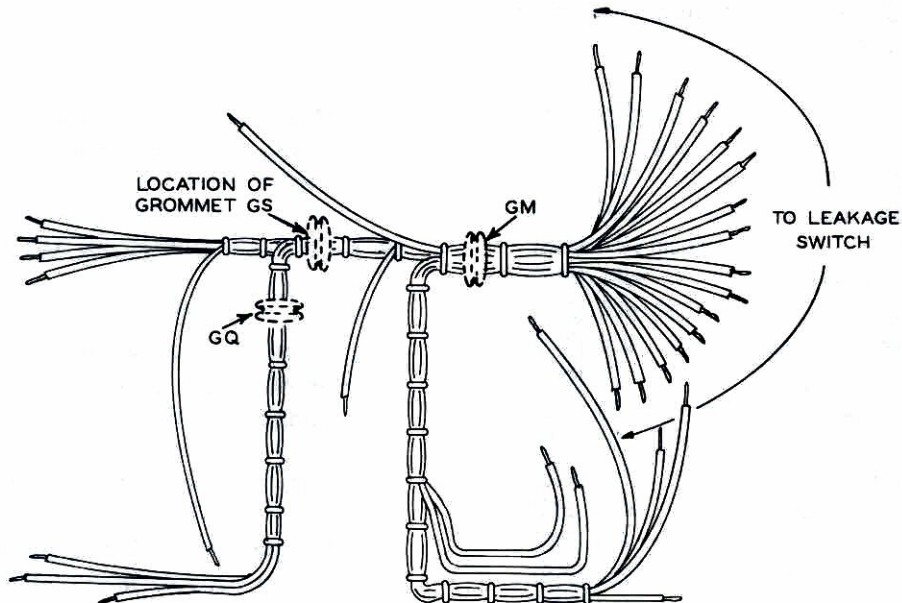

LEAKAGE SWITCH CABLE HARNESS
PT. NO 134-11

- () Connect a bare jumper from SNA7 (NS) through SNA8 (NS) to SNB9 (S-1). Now solder SNA8.
- () Connect a bare jumper from SNC9 (NS) to SNB11 (S-1).
- () Connect a 2 1/2" length of black wire from SNC12 (NS) to SNC5 (NS).
- () Connect a 1 1/4" length of black wire from SNB6 (NS) to SNA7 (S-2).
- () Connect a 2.7 KΩ resistor (red-violet-red) from SNC5 (S-2) to SNB6 (S-3).

<u>Lead Color</u>	<u>Connect to</u>
() Yellow-Green	SND10 (S-1)
() Yellow-Black	SND12 (S-1)
() Gray	SNC9 (S-2)
() White	SNC12 (S-2)
() Orange	SNA9 (S-1)

Connect harness leads as follows:

<u>Lead Color</u>	<u>Connect to</u>
() Green-White	SND1 (S-1)
() Yellow-Blue	SND4 (S-1)
() Green-Black	SND5 (S-2)
() Yellow-Red	SND6 (S-1)
() Black	SNC1 (S-2)
() Violet	SNC6 (S-1)
() Blue	SNB2 (S-1)
() Green	SNB3 (S-1)
() Yellow	SNA2 (S-1)
() Brown	SNA3 (S-1)
() Red	SNA5 (S-1)

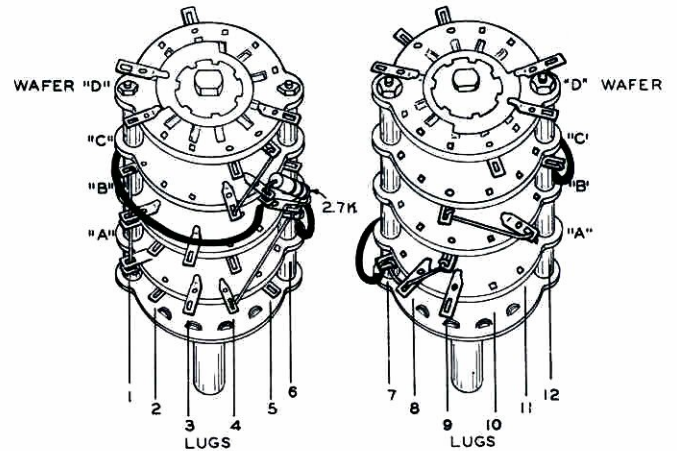
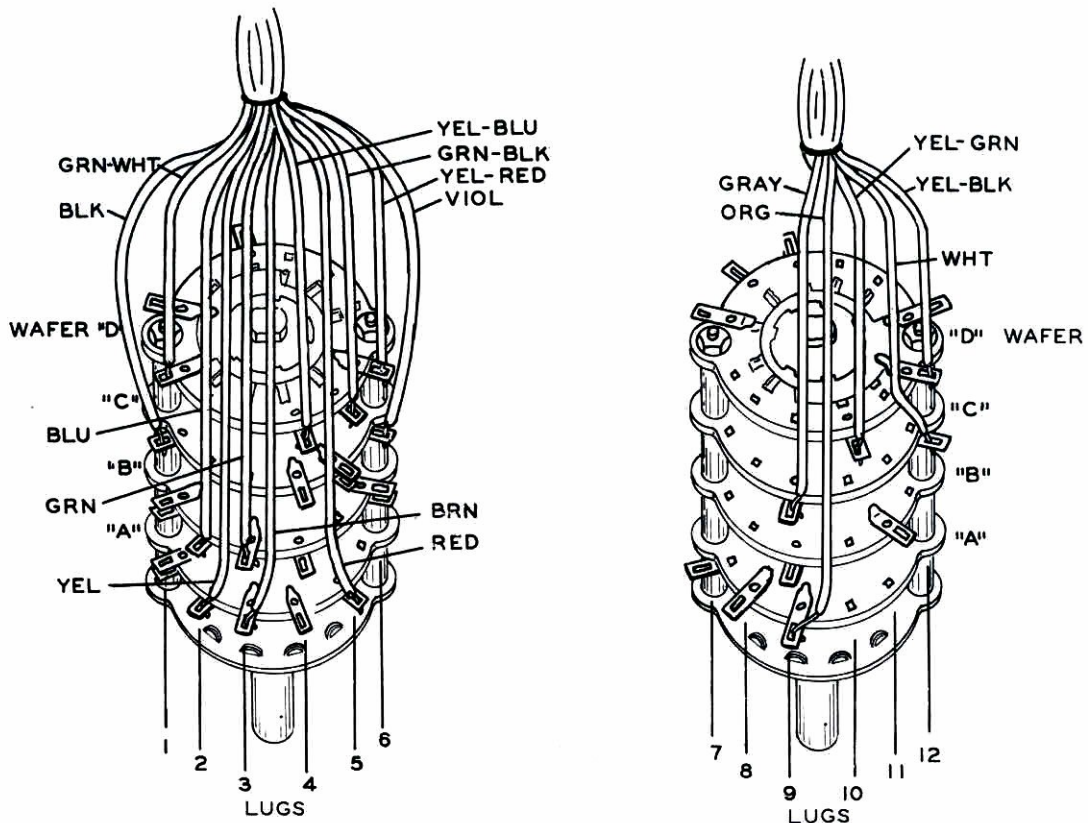

Figure 47

Figure 48



INSTALLATION OF LEAKAGE SWITCH

- () Start the cable harness through GM, as in the case of the PLATE switch. Before mounting the switch to the panel, connect the white-black lead from the PLATE switch harness to SNB4 (S-1).
- () Mount the LEAKAGE switch (#1 terminals toward top of panel) and install the knob.
- () Bend the cable harness at right angles to assume the position shown in Figure 49.

- () Pass the remaining leads through GQ and GP. See Figures 50 and 52.

<u>Lead Color</u>	<u>Connect to</u>
() Yellow-Blue	SS5 (S-1)
() Yellow-Red	CC2 (S-1)

The yellow lead will be connected later to the GRID CURRENT TEST switch SW.

Connect the following leads on the sub-chassis:

<u>Lead Color</u>	<u>Connect to</u>
() Gray	F1 (NS)
() Violet	CD1 (NS)
() Green-Black	D1 (NS)
() Black	D2 (NS)
() Yellow-Black	C1 (NS)
() Green-White	C3 (NS)
() Yellow-Green	C5 (NS)
() Brown	A1 (NS)

Pass all remaining leads through grommet GS. See Figure 49.

- | | |
|------------|------------|
| () White | SP2 (S-2) |
| () Blue | SX2 (S-1) |
| () Orange | SX13 (S-1) |
| () Red | SX10 (S-1) |
- () Pass the green lead through GO and connect it to SF6 (S-2). See Figure 29 for location of SF6.

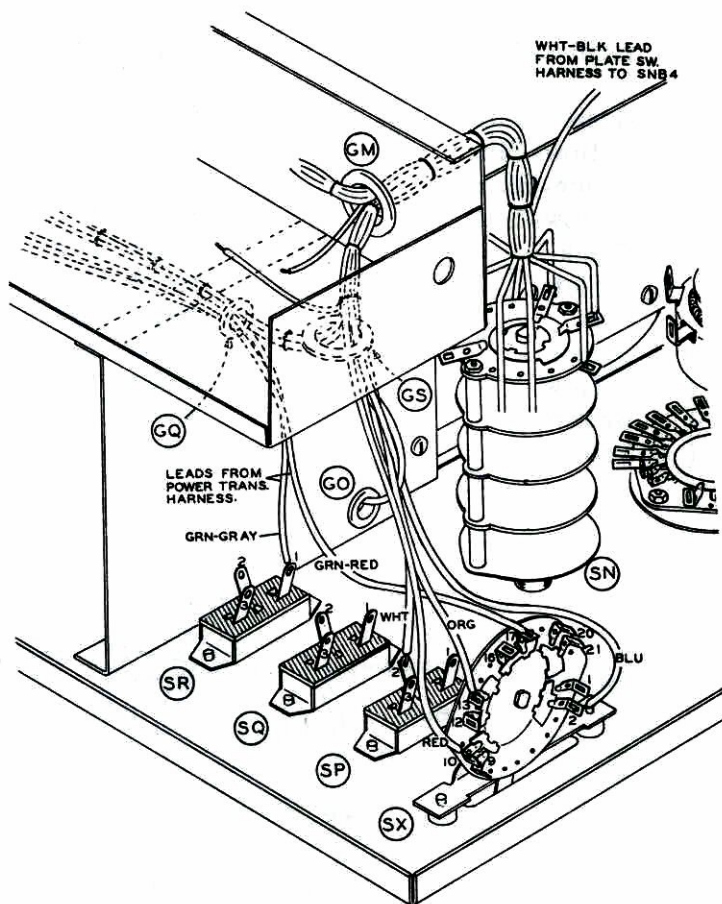

Figure 49

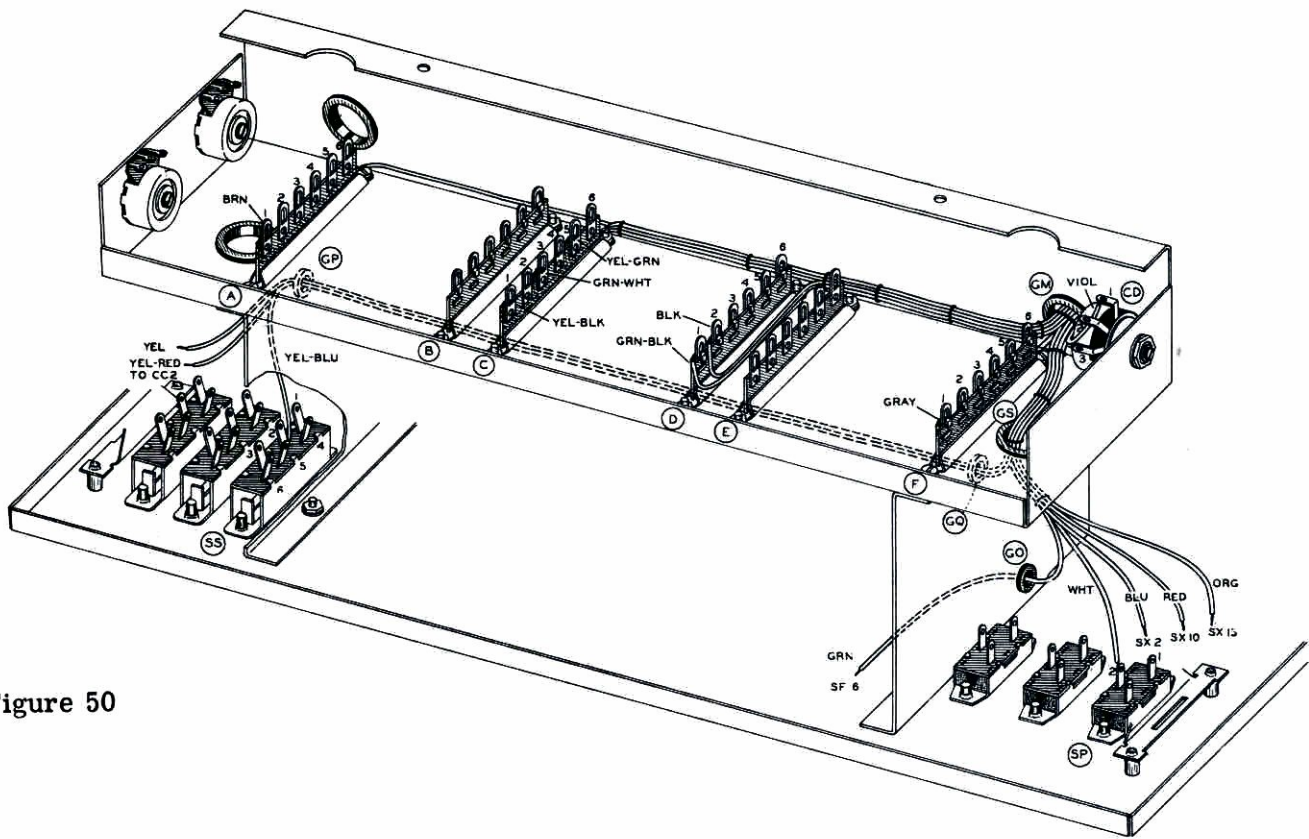

Figure 50

INSTALLATION OF POWER TRANSFORMER HARNESS

() Locate the power transformer harness (#134-16). Start the LIFE switch end of the harness (end nearest the long green-red lead) through grommets GH, GL and GR, starting from the top of the chassis. When the harness has been properly positioned in reference to these three grommets, bend

it at a right angle above the chassis and pass the transformer end of the harness through GD. Bend the LIFE switch end of the harness toward the switch, keeping it parallel to the sub-chassis. Now make another bend toward the panel at the breakout point just above the LIFE switch SZ. See Figure 52.

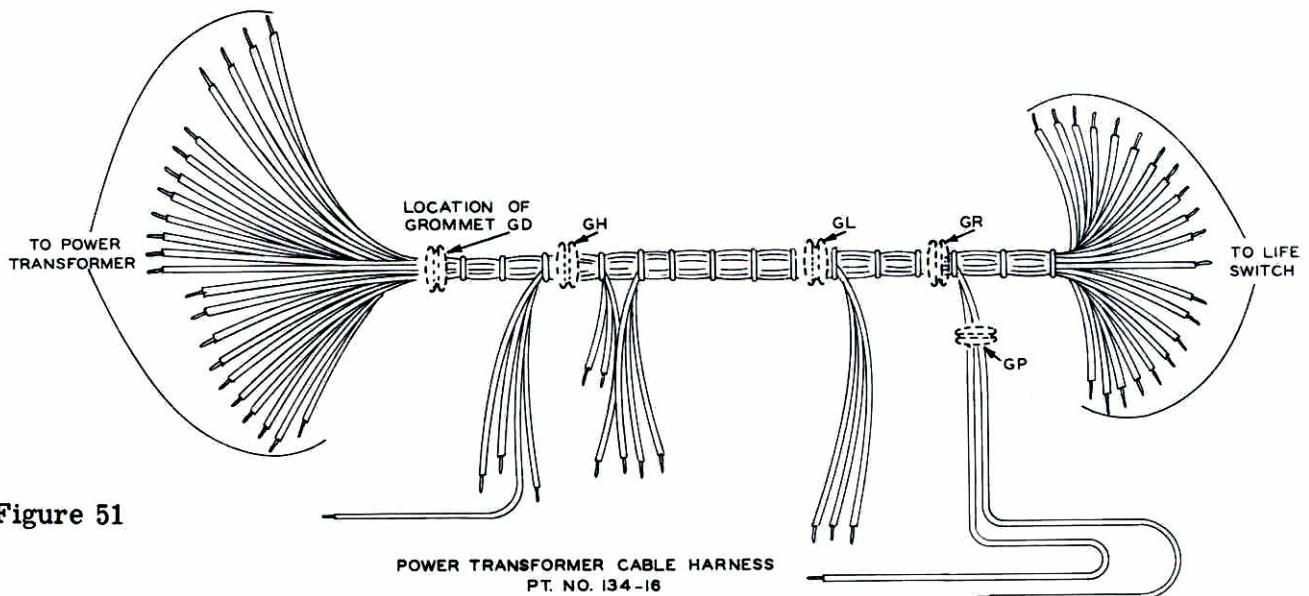

Figure 51

POWER TRANSFORMER CABLE HARNESS
PT. NO. 134-16

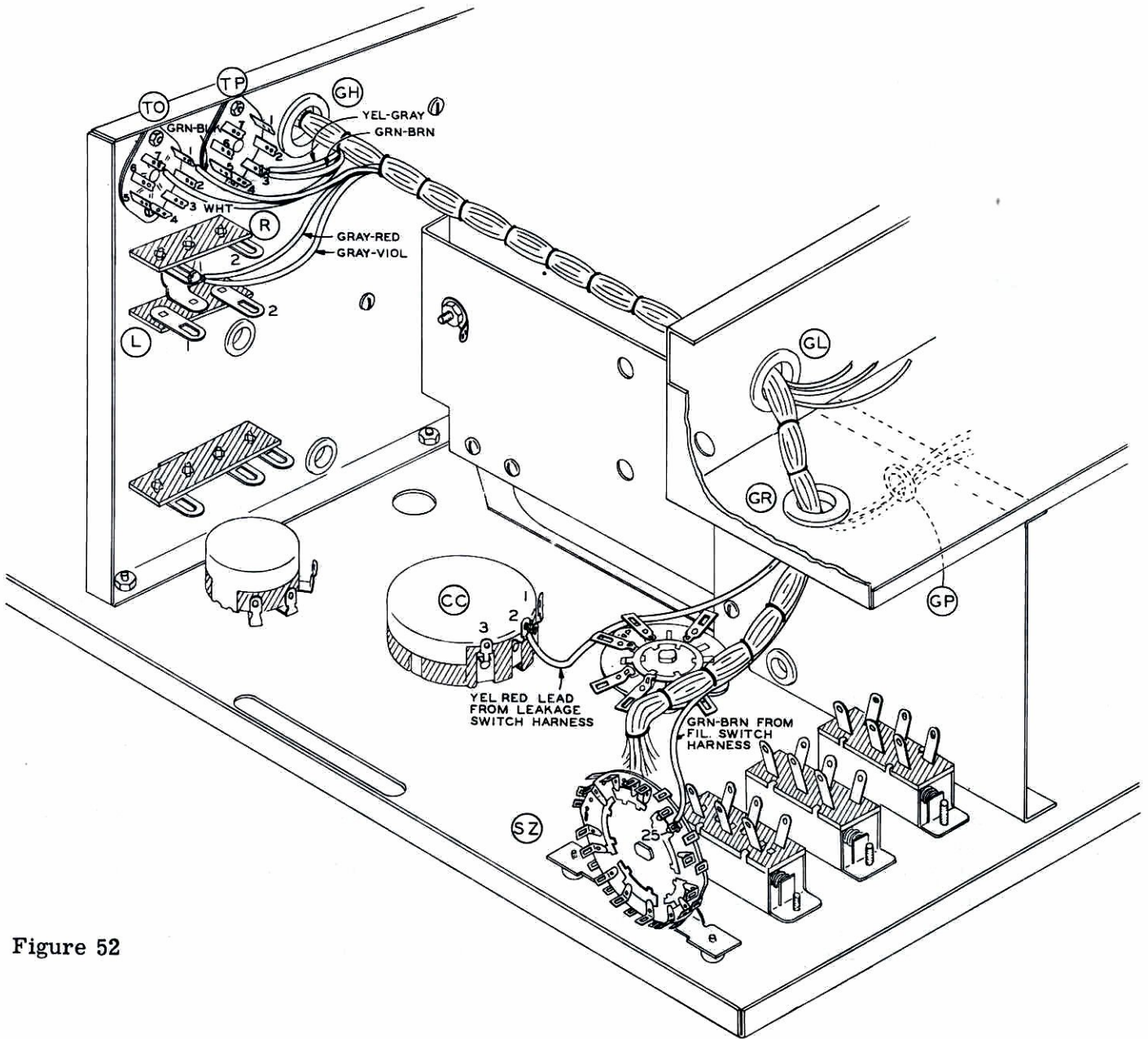

Figure 52

- () Pass the green-red and green-gray leads through GP and GQ. See Figure 49.
- () Connect the green-red lead to SX17 (S-1).
- () Connect the green-gray lead to SR1 (S-2).

Connect the leads under the chassis as follows:

<u>Lead Color</u>	<u>Connect to</u>
() Green-Black	TO1 (S-2)
() Gray-Red	R1 (NS)

<u>Lead Color</u>	<u>Connect to</u>
() Gray-Violet	R1 (NS)
() Yellow-Gray	TP3 (NS)
() Green-Brown	TP3 (S-4)
() White	TO7 (S-1)

Connect the leads above the chassis as follows:

<u>Lead Color</u>	<u>Connect to</u>
() Green-Brown	N1 (NS)
() Green-Red	O1 (NS)
() Green-Gray	H1 (NS)
() Yellow-Black	TC1 (S-2)

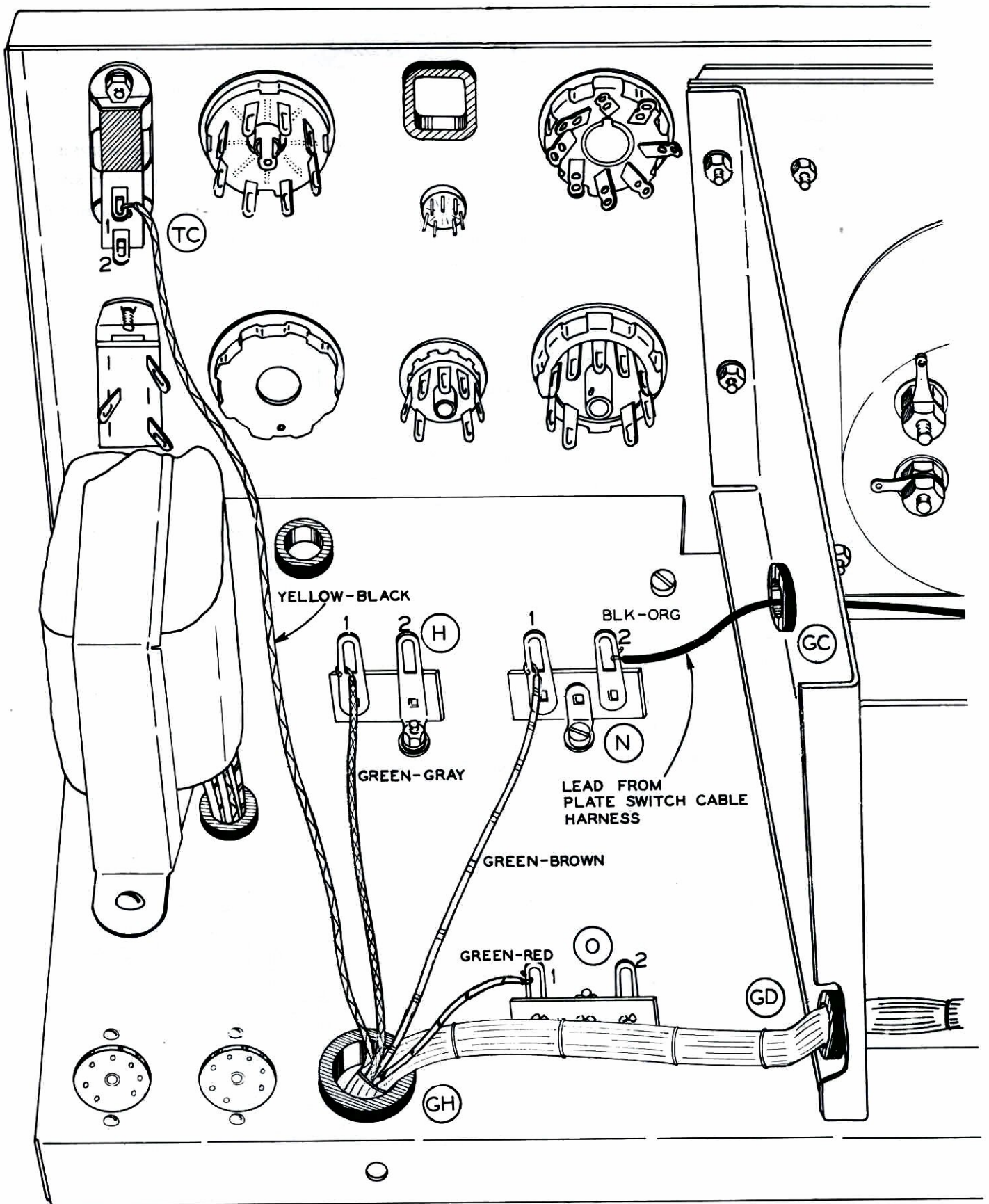

Figure 53

Connect the LIFE switch leads as shown in Figure 54.

- 7. () Green-black lead to SZ21 (S-1).
- 8. () White-brown lead to SZ19 (S-1).
- 9. () Violet lead to SZ18 (S-1).
- 10. () Blue lead to SZ15 (S-1).



- 1. () Black lead to SZ22 (S-1).
- 2. () White-violet lead to SZ23 (S-1).
- 3. () Yellow lead to SZ24 (S-1).
- 4. () Yellow-black lead to SZ26 (S-1).
- 5. () White-red lead to SZ27 (S-1).
- 6. () White-green lead to SZ28 (S-1).

Figure 54

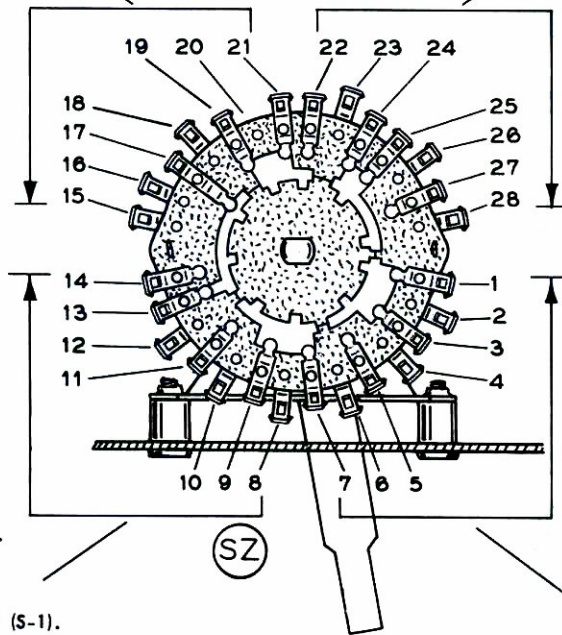

- 11. () Gray lead to SZ8 (S-1).
- 12. () Gray-red lead to SZ9 (S-1).
- 13. () Green lead to SZ10 (S-1).
- 14. () Yellow-green lead to SZ-11 (S-1).
- 15. () Orange lead to SZ13 (S-1).
- 16. () Brown lead to SZ14 (S-1).

- 17. () White-orange lead to SZ7 (S-1).
- 18. () Yellow-brown lead to SZ5 (S-1).
- 19. () White-yellow lead to SZ4 (S-1).
- 20. () White-black lead to SZ2 (S-1).
- 21. () Yellow-red lead to SZ1 (S-1).

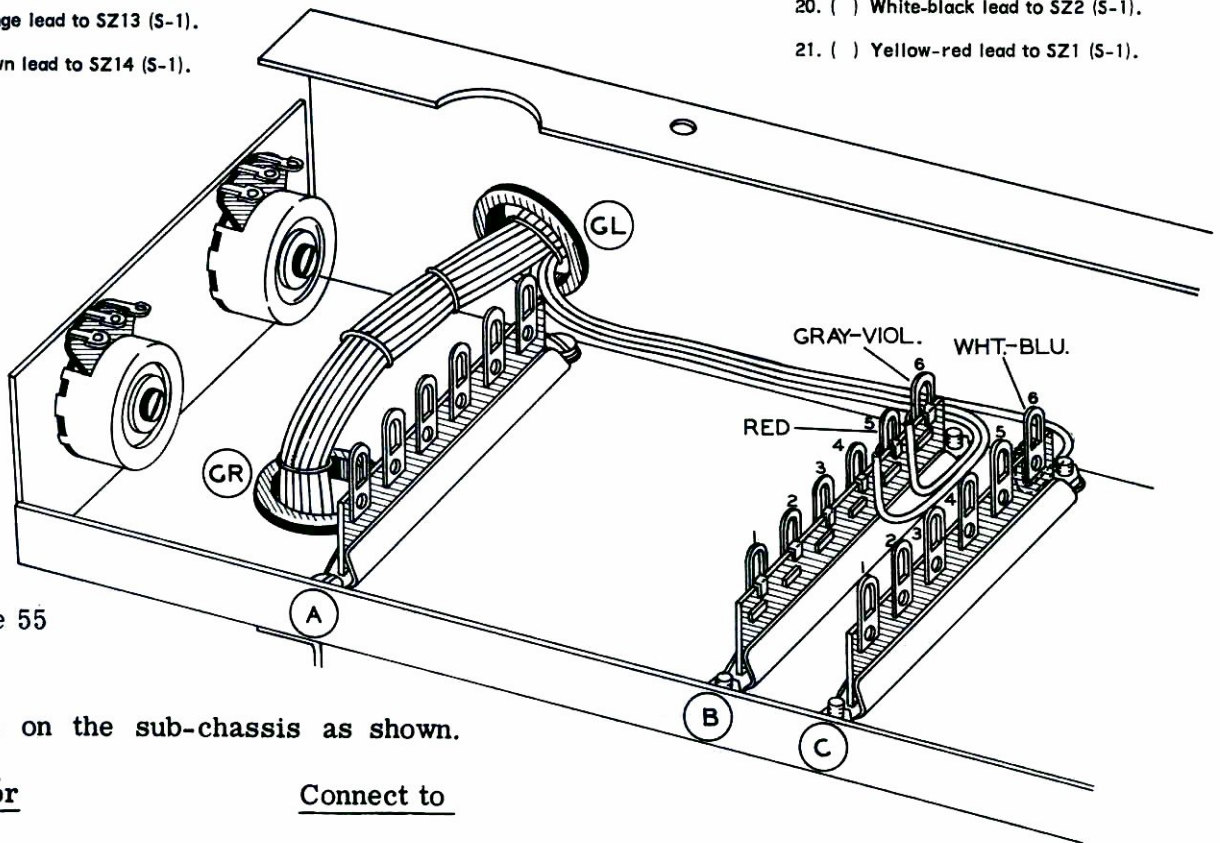

Figure 55

Connect leads on the sub-chassis as shown.

<u>Lead Color</u>	<u>Connect to</u>
() Red	B5 (NS)
() Gray-Violet	B6 (NS)
() White-Blue	C6 (NS)

Connections to the power transformer will be made later.

GRID CURRENT TEST SWITCH SUB-ASSEMBLY

Switch - Part No. T-63-223

Harness - Part No. 134-12

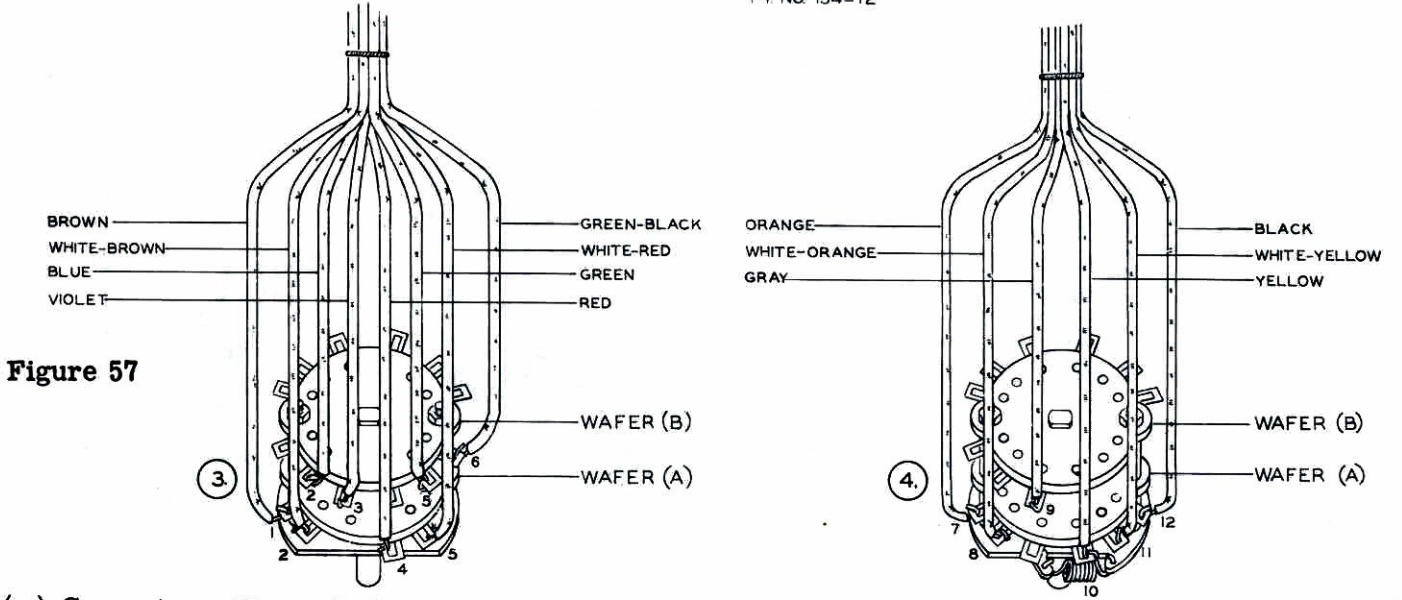
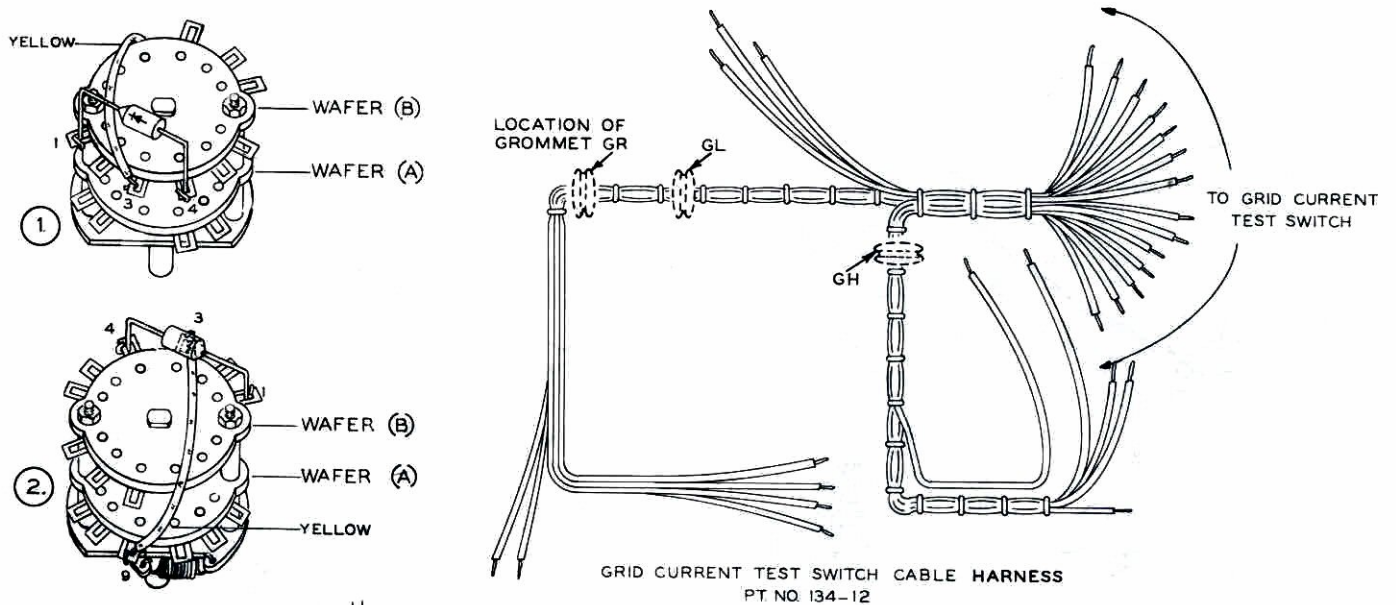

Figure 57

() Connect a silicon diode from SWB1 (S-1) to SWB4 (S-1). The (+) end of the diode is connected to SWB1.

() Connect a 3" yellow wire from SWA9 (S-1) to SWB3 (NS).

Connect the harness leads to the switch as follows:

<u>Lead Color</u>	<u>Connect to</u>
() Blue	SWB2 (S-1)
() Violet	SWB3 (S-2)
() Green	SWB5 (S-1)
() Green-Black	SWB6 (S-1)

<u>Lead Color</u>	<u>Connect To</u>
() Brown	SWA1 (S-1)
() White-Brown	SWA2 (S-1)
() Red	SWA4 (S-1)
() White-Red	SWA5 (S-1)
() Gray	SWB9 (S-1)
() Orange	SWA7 (S-1)
() White-Orange	SWA8 (S-1)
() Yellow	SWA10 (S-1)
() White-Yellow	SWA11 (S-1)
() Black	SWA12 (S-1)

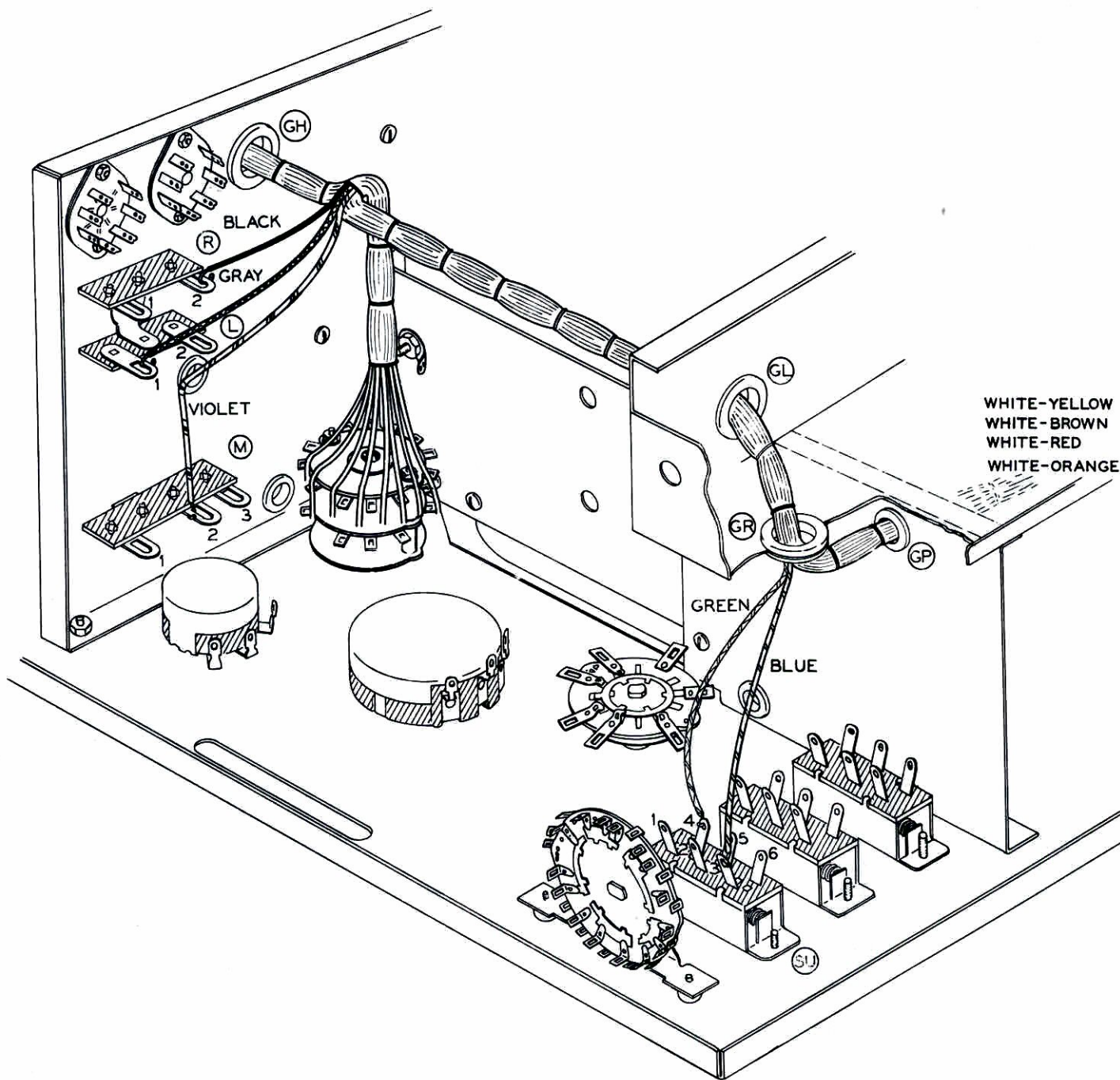

Figure 58

() Install the switch as shown in Figure 58. Again the #1 terminals should be toward the top of the panel.

Bend the cable as shown in Figures 58 and 59. Pass the leads through their respective grommets.

() Connect the blue lead to SU3 (S-1).

() Connect the green lead to SU4 (S-1).

() Pass the remaining leads through grommet GP, to be connected later to the CALIBRATE switch.

CHASSIS CONNECTIONS

Lead Color

Connect to

() Violet

M2 (S-3)

() Gray

L1 (S-3)

() Black

R2 (S-2)

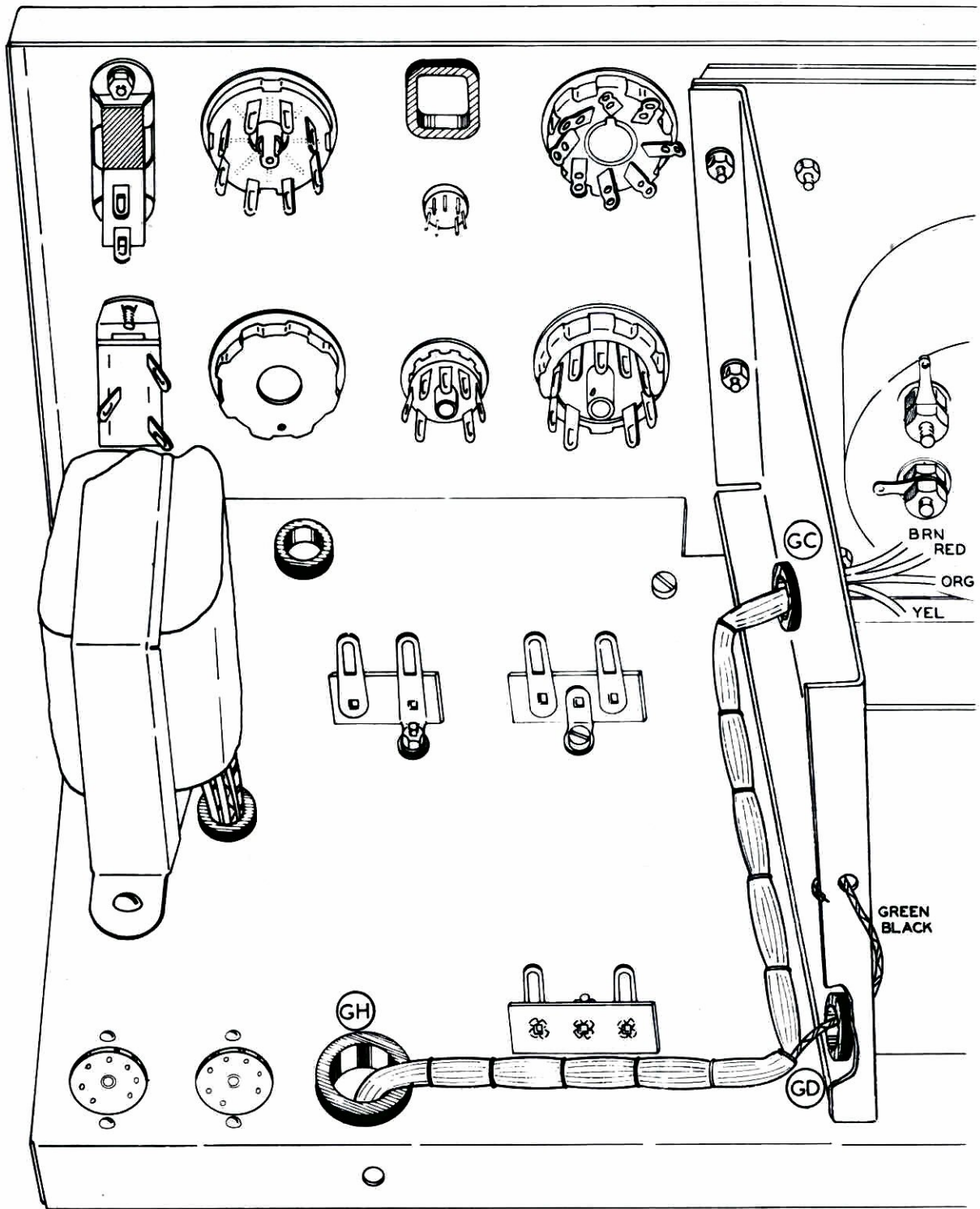

Figure 59

Connect the harness leads to the meter as follows:

<u>Lead Color</u>	<u>Connect to</u>
() Brown	Meter Terminal 1 (S-1)
() Red	Meter Terminal 2 (S-1)
() Orange	Meter Terminal 3 (S-1)
() Yellow	Meter Terminal 4 (S-1)

() Pass the green-black lead through GD and temporarily through the mounting hole in the flange. This lead will be connected later to the power transformer.

() See Figure 61. Connect the yellow lead from the LEAKAGE switch harness to SWB7 (S-1).

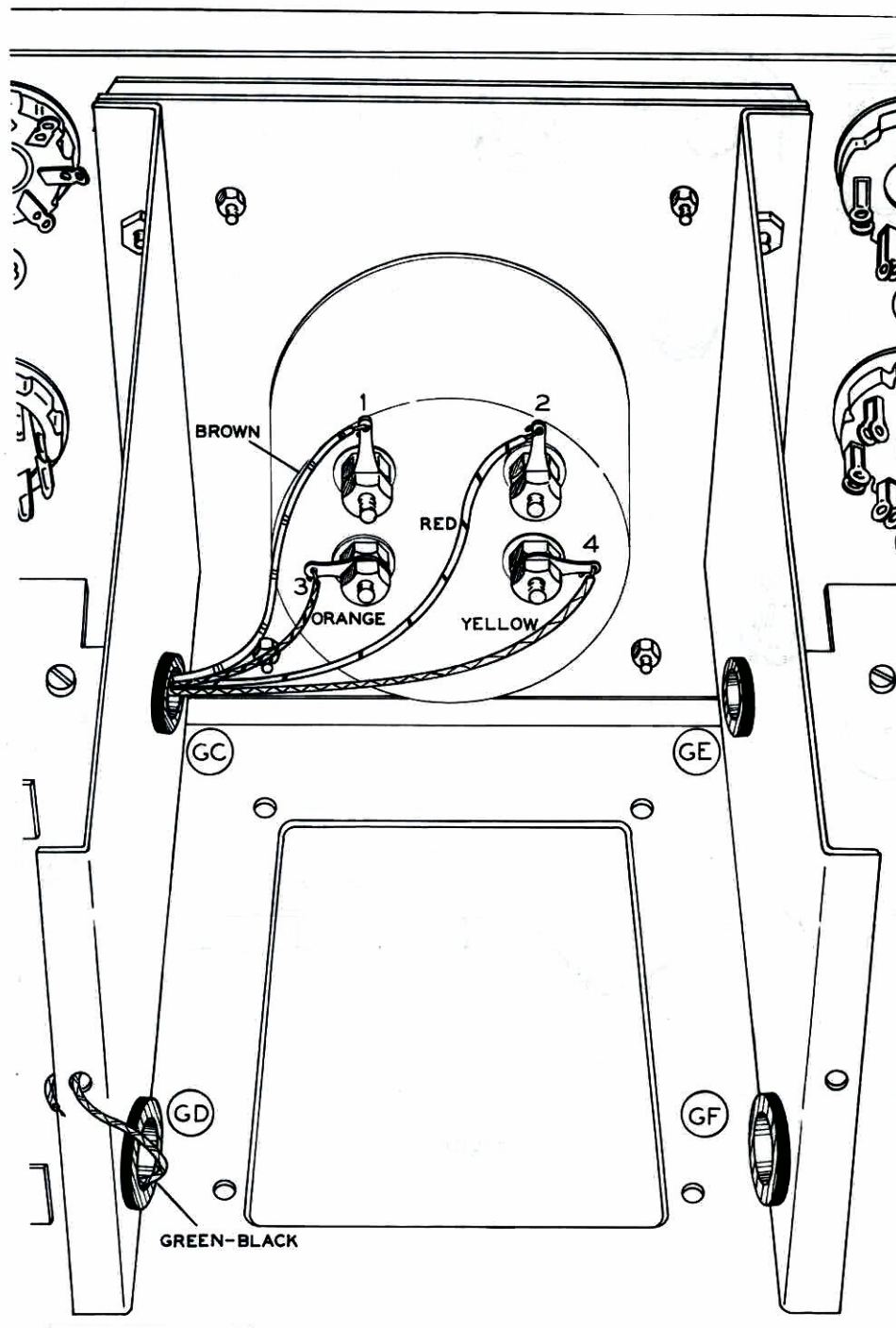

Figure 60

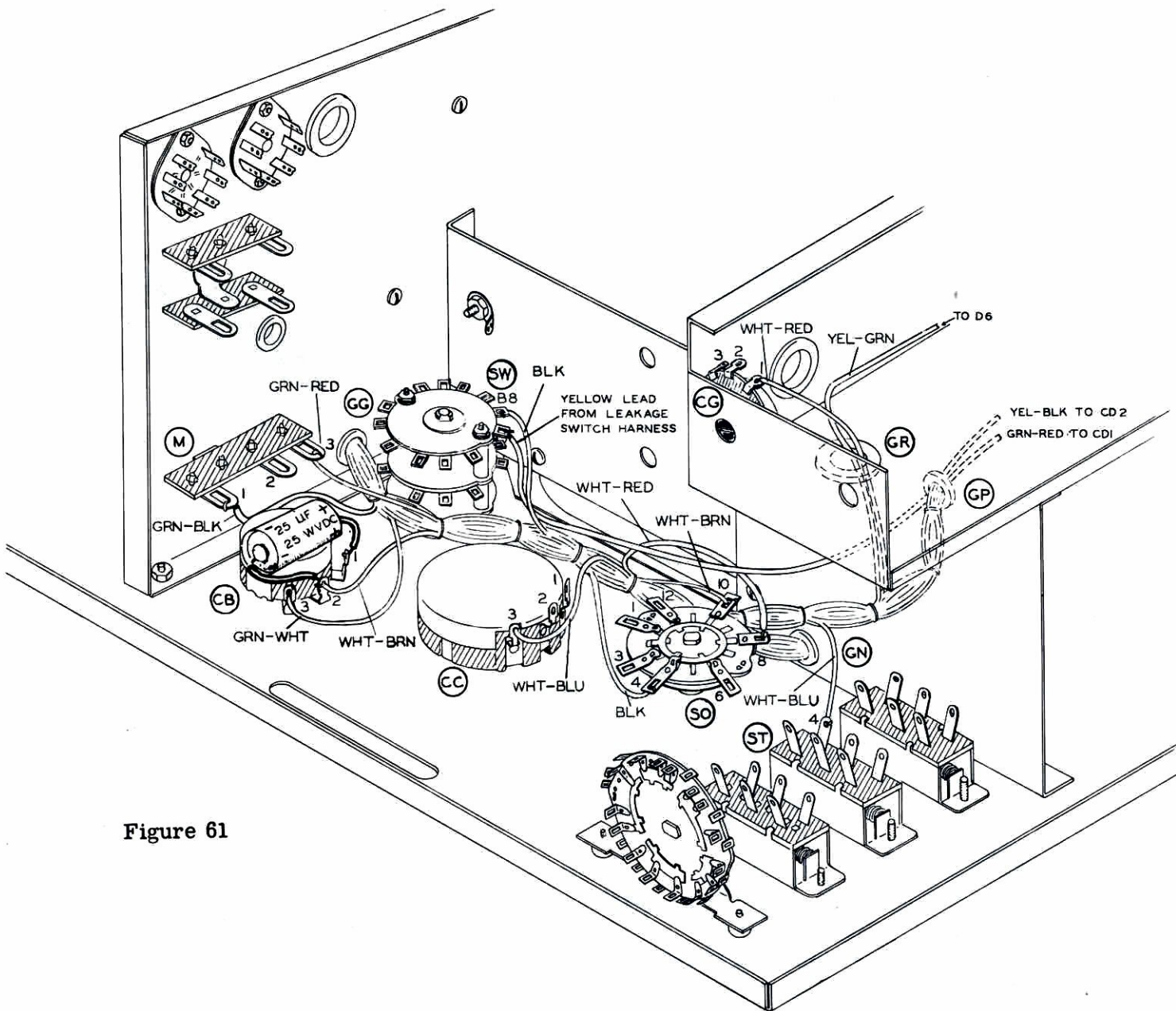

Figure 61

Connect leads from the SELECTOR switch to tube socket harness as follows:

<u>Lead Color</u>	<u>Connect to</u>
() Black (nearest SW)	SWB8 (S-1)
() Green-Red	M3 (S-4)
() Green-Black	M1 (S-2)
() White-Brown	CB2 (NS)
() Green-White	CB3 (S-1)
() White-Blue	CC3 (S-1)
() White-Brown	SO10 (NS)
() Black (nearest SO)	SO4 (S-1)
() White-Red	SO8 (S-2)
() White-Blue	ST4 (NS)

- () Pass the white-red and yellow-green leads through grommet GR.
- () Connect the white-red lead to CG1 (S-1)
- () Connect the yellow-green lead to D6 (NS). See Figures 61 and 62.
- () Pass the yellow-black and green-red leads through GP, GQ and GS.
- () Connect the yellow-black lead to CD2 (S-1).
- () Connect the green-red lead to CD1 (NS).
- () Connect a 25 μ fd, 25 V capacitor from CB1 (S-2) to CB2 (S-2), (negative lead to CB2). See Figure 61. Use sleeving.

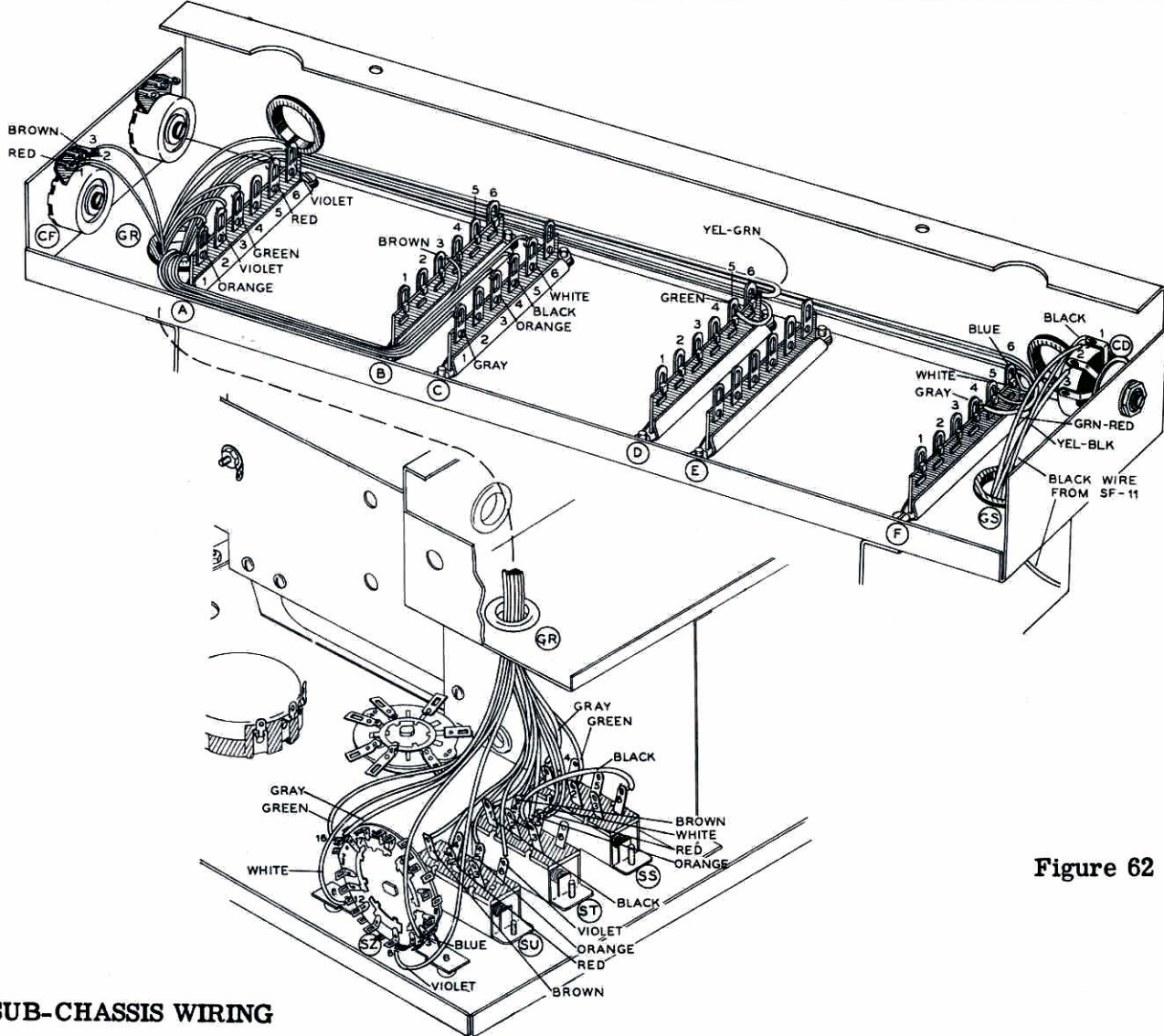

Figure 62

SUB-CHASSIS WIRING

() Connect the black lead coming from SF11 to CD1 (NS).

Pass all leads through grommet GR and connect as follows:

<u>Length</u>	<u>Color</u>	<u>From</u>	<u>To</u>
() 20"	Blue	F6 (NS)	SZ3 (S-1)
() 8"	Violet	A2 (NS)	SZ6 (S-1)
() 20"	White	F5 (NS)	SZ12 (S-1)
() 21"	Gray	F4 (NS)	SZ17 (S-1)
() 17"	Green	D5 (NS)	SZ16 (S-1)
() 11"	Brown	SU1 (S-1)	B3 (NS)
() 6"	Red	SU2 (S-1)	A5 (NS)
() 11"	Orange	SU5 (S-1)	C3 (NS)
() 6"	Violet	SU6 (S-1)	A6 (NS)
() 11"	Black	ST1 (S-1)	C4 (NS)
() 6"	Orange	ST3 (NS)	A1 (NS)
() Bare Jumper		ST2 (S-1)	ST3 (NS)
() 6"	Brown	ST4 (S-2)	CF3 (S-1)
() 12"	White	ST5 (NS)	C5 (NS)
() 6"	Red	ST5 (S-2).	CF1 (S-1) and CF2 (S-1)
() 10"	Gray	SS1 (S-1)	C1 (NS)
() 6"	Green	SS2 (S-1)	A3 (NS)
() 4"	Black	SS6 (S-1)	ST3 (S-3)

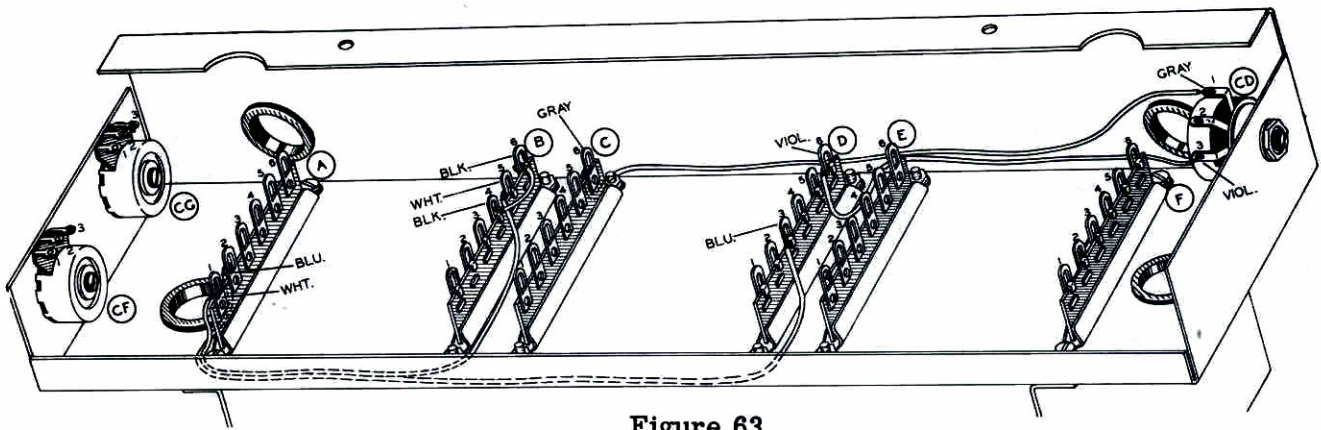

Figure 63

Install leads on sub-chassis as follows:

<u>Length</u>	<u>Color</u>	<u>From</u>	<u>To</u>
() 7"	White	A1 (NS)	B5 (NS)
() 11"	Blue	A2 (NS)	D3 (NS)
() 11"	Gray	C6 (NS)	CD1 (S-4)
() 7"	Violet	D6 (NS)	CD3 (S-1)
() 1 1/2"	Black	B6 (NS)	B4 (NS)
() Bare Jumper		CG2 (NS)	CG3 (S-1)
() Bare Jumper		E1 (NS)	E2 (NS)
() Bare Jumper		F2 (NS)	F3 (NS)

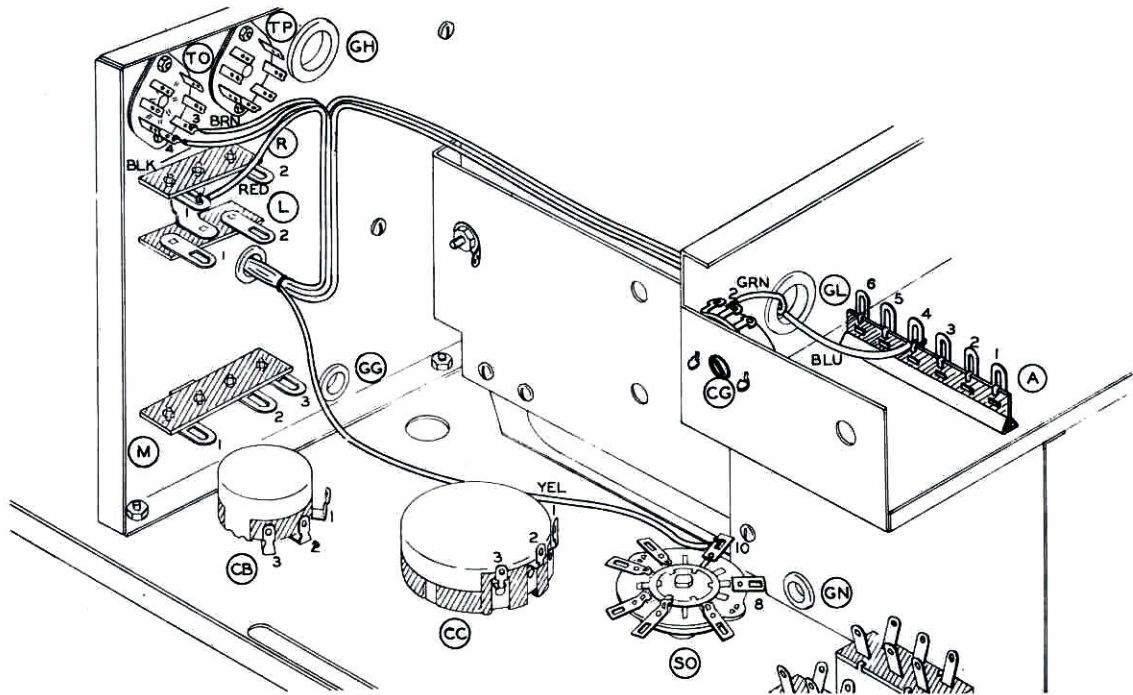

Figure 64

Connect the oscillator transformer leads as follows:

<u>Lead Color</u>	<u>Connect to</u>	<u>Lead Color</u>	<u>Connect to</u>
() Red	R1 (S-4)	() Blue	A4 (NS)
() Brown	TO3 (S-2)	() Green	CG2 (S-2)
() Black	TO4 (S-1)	() Yellow	SO10 (S-3)

INSTALLATION OF COMPONENTS ON SUB-CHASSIS

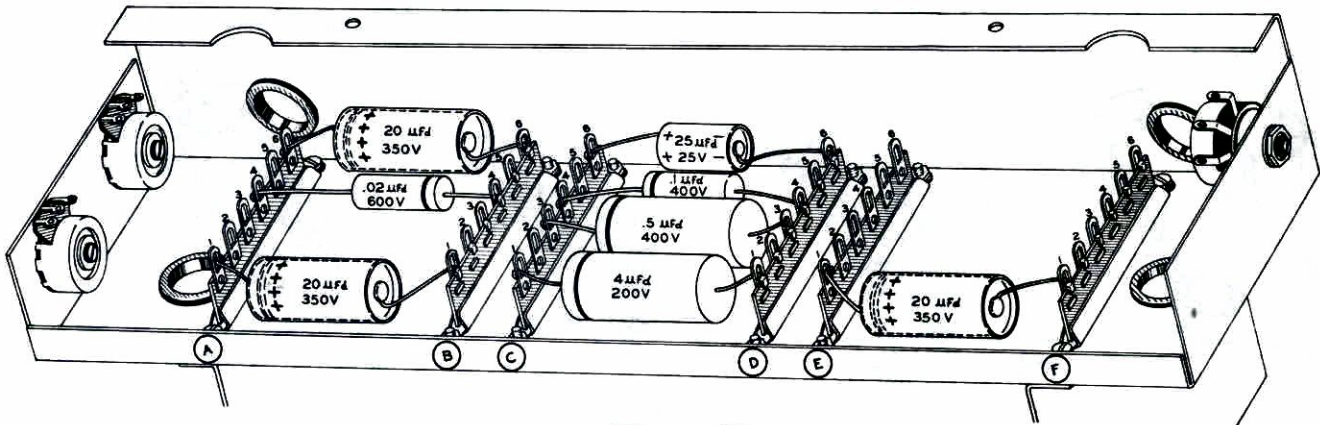

Figure 65

Capacitors (Observe polarity of electrolytic capacitors closely.)

Value	From	To
() 20 μ fd 350 V	Positive A6 (NS)	Negative B6 (S-3)
() 20 μ fd 350 V	Positive A1 (NS)	Negative B1 (NS)
() 20 μ fd 350 V	Positive E1 (S-2)	Negative F1 (NS)
() 25 μ fd 25 V	Positive C6 (S-3)	Negative D6 (NS)
() .02 μ fd 600 V	A4 (NS)	B4 (S-3)
() 4 μ fd 200 V	C1 (S-3)	D1 (S-2)
() .5 μ fd 400 V	C3 (S-3)	D3 (NS)
() .1 μ fd 400 V	C4 (S-2)	D4 (S-2)

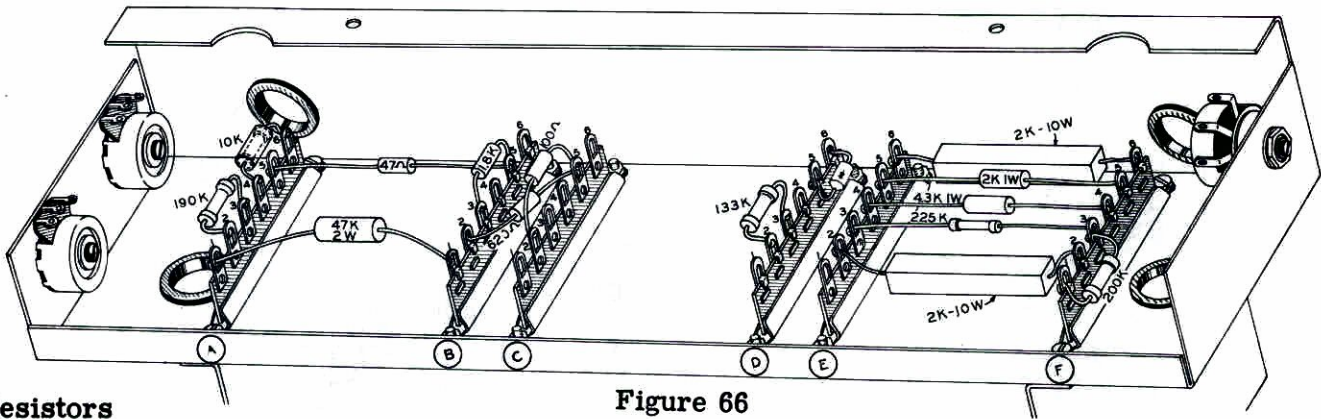

Figure 66

Resistors

Value	Color Code	From	To
() 10 K Ω 1%		A6 (S-3)	A4 (S-3)
() 190 K Ω 1%		A2 (S-4)	A3 (S-2)
() 47 Ω 1/2 W	Yellow-Violet-Black	A5 (S-2)	B5 (NS)
() 47 K Ω 2 W	Yellow-Violet-Orange	A1 (S-5)	B1 (S-3)
() 1.8 K Ω 1/2 W	Brown-Gray-Red	B3 (S-2)	B5 (S-5)
() 620 Ω 1/2 W 5%	Blue-Red-Brown	B2 (S-2)	C5 (NS)
() 100 Ω 1/2 W 5%	Brown-Black-Brown	C2 (S-2)	C5 (S-5)
() 133 K Ω 1%		D2 (S-2)	D3 (S-3)
() 2 K Ω 10 W		E6 (S-2)	F6 (S-3)
() 2 K Ω 1 W 5%	Red-Black-Red	E5 (S-2)	F5 (S-2)
() 4.3 K Ω 1 W 5%	Yellow-Orange-Red	E4 (S-2)	F4 (S-3)
() 225 K Ω 1%		E3 (S-2)	F3 (NS)
() 2 K Ω 10 W		E2 (S-3)	F2 (S-2)
() 200 K Ω 1%		F1 (S-4)	F3 (S-4)
() Silicon diode rectifier		+(Red) D5 (S-2)	-(Black) D6 (S-4)

ON TOP OF THE CHASSIS

() Connect lead #10 of the P.E.C. (#84-17) to H2 (S-1).

Mount the two 100 μ f capacitors as close to terminal strip O as possible so that the screw head holding terminal strip N is accessible.

<u>Component</u>	<u>From</u>	<u>To</u>
() 100 μ f 50 V capacitor	Positive O1 (NS)	Negative N1 (NS)
() 100 μ f 50 V capacitor	Positive O2 (NS)	Negative N1 (S-3)
() Silicon diode rectifier	+ (Red) O2 (NS)	- (Black) N2 (S-2)
() 360 Ω 7 W resistor	O1 (S-3)	O2 (S-3)

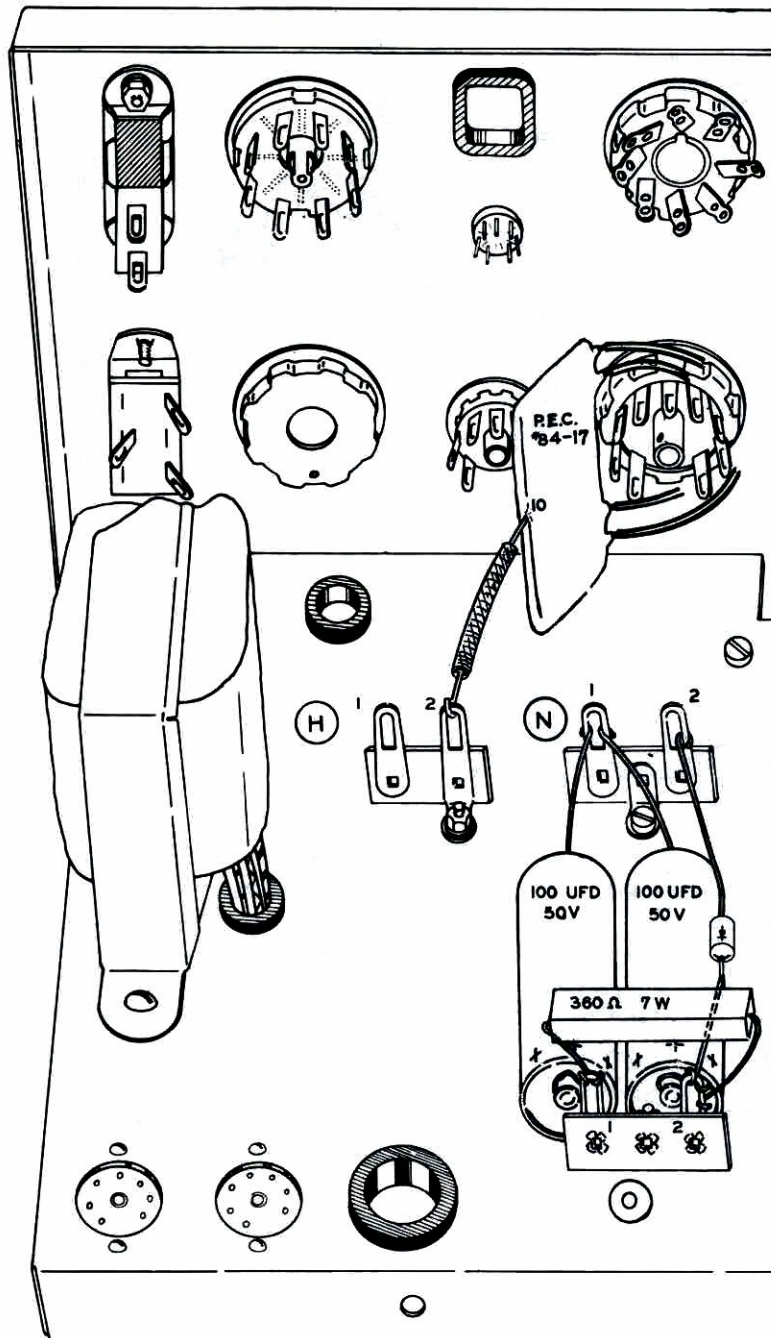

Figure 67

() Using 8-32 nuts and #8 lockwashers, mount the ballast capacitor. Observe terminal orientation closely. Connect the four leads from the FILAMENT switch harness as shown.

<u>Lead</u>	<u>Connect to</u>
() Green	Capacitor terminal 1 (S-1)
() Red	Capacitor terminal 2 (S-1)
() Green-Brown	Capacitor terminal 3 (S-1)
() Brown	Capacitor terminal 4 (S-1)

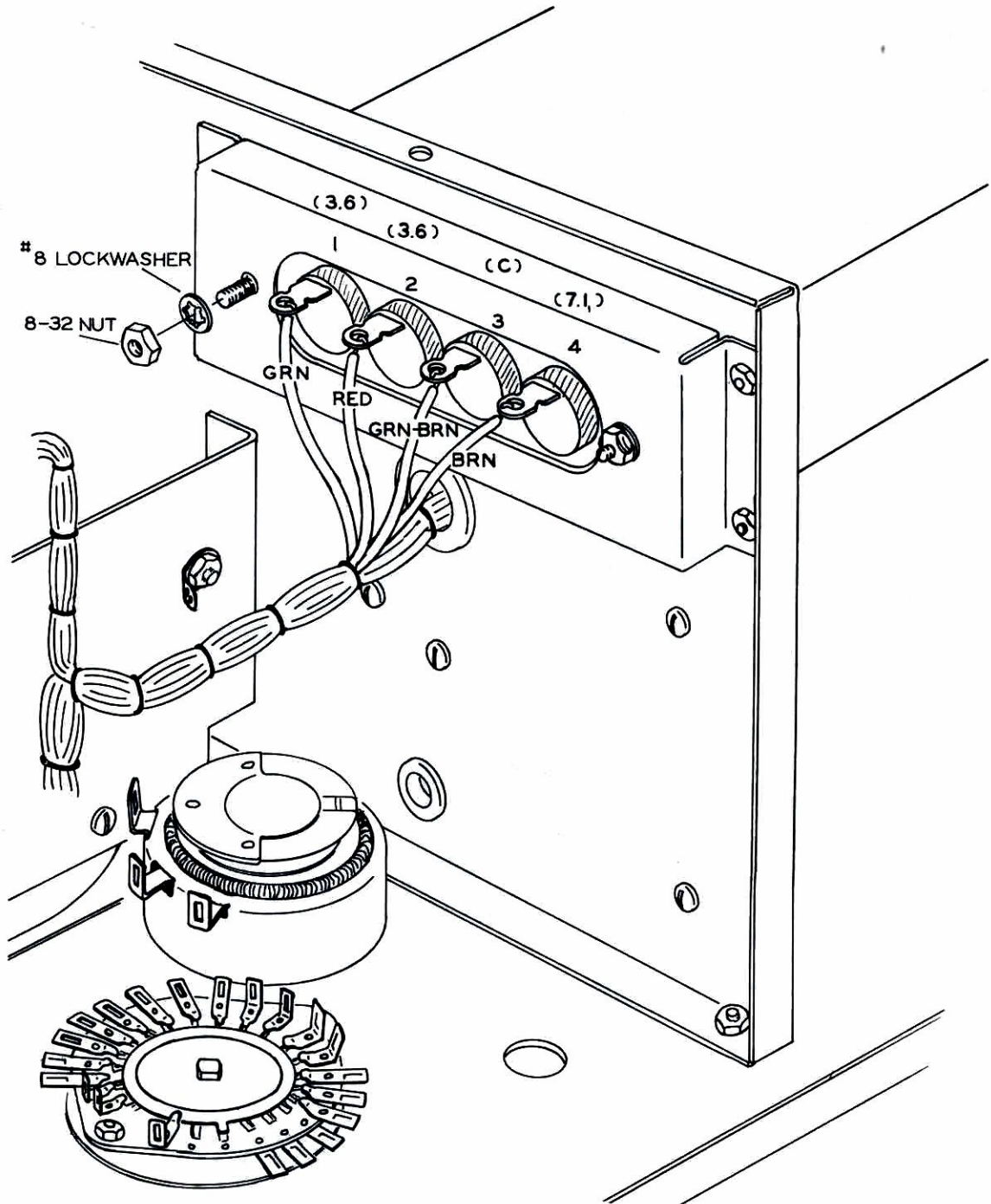

Figure 68

POWER TRANSFORMER INSTALLATION AND WIRING

- () Before installing the power transformer, check the transformer bolts to be sure they have not become loose during shipment. Tighten if necessary.
- () Install the four mounting spacers on the transformer bolts.
- () After bending the cable harness leads toward the rear, mount the transformer, using 8-32 RHMS and #8 lockwashers.
- () Connect the leads to the transformer as indicated below. Dress all leads as shown, pushing any excess lead length between the transformer and the panel support brackets.

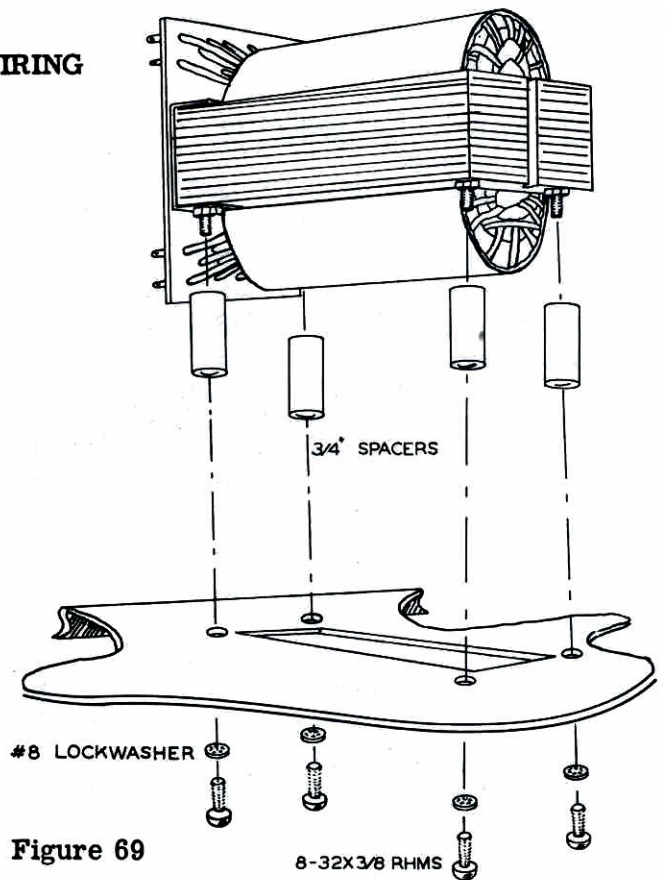

Figure 69

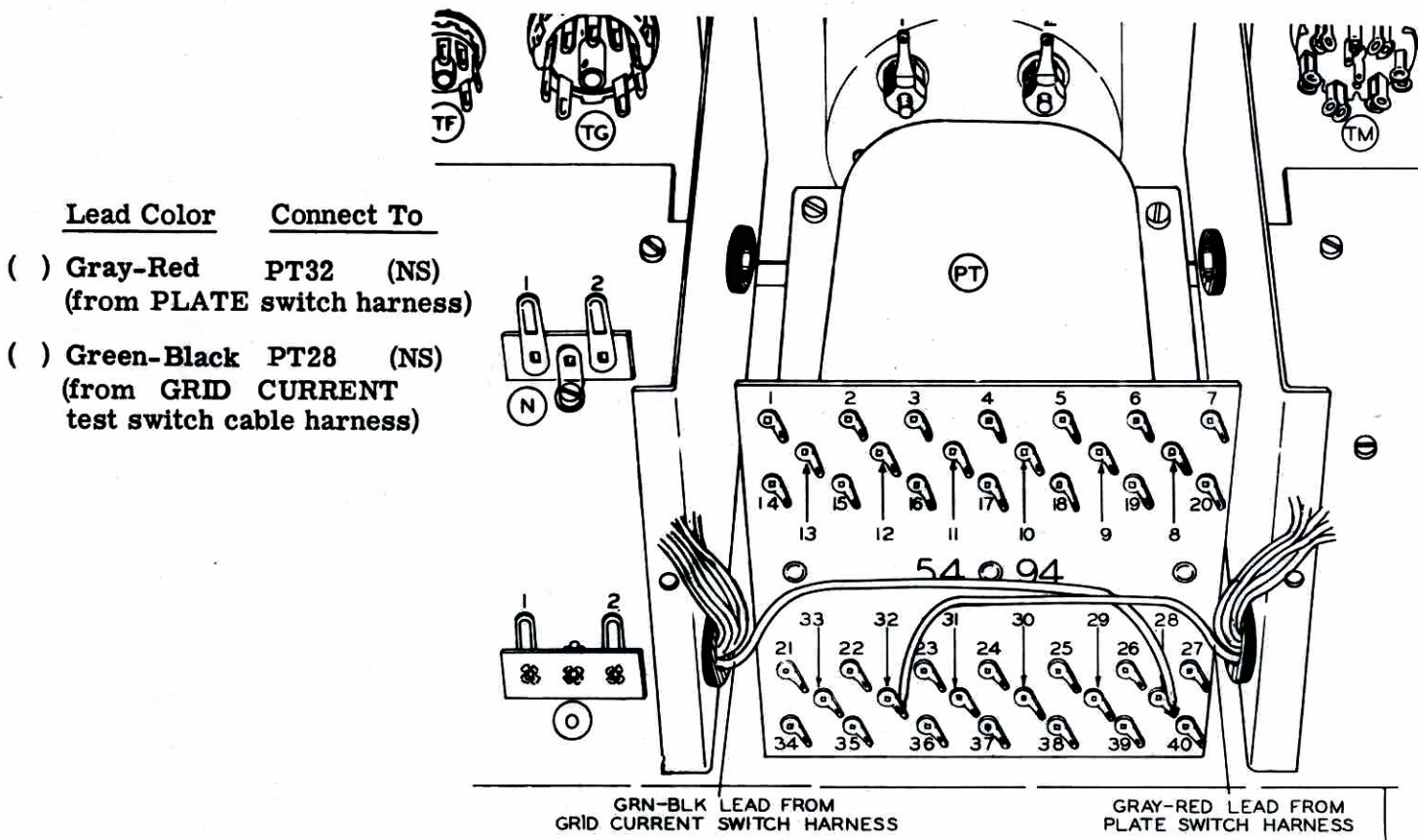

Figure 70

LEADS NEAREST BALLAST CAPACITOR (filament switch cable harness)

<u>Lead Color</u>	<u>Connect to</u>
() White-Yellow	PT3 (S-1)
() White-Gray	PT4 (S-1)
() White-Black	PT5 (S-1)
() Yellow-Brown	PT6 (S-1)
() White-Orange	PT7 (S-1)
() White-Brown	PT8 (S-1)
() Blue	PT9 (S-1)
() Yellow	PT22 (S-1)
() Violet	PT23 (S-1)
() White-Violet	PT24 (S-1)
() Yellow-Red	PT25 (S-1)
() White-Red	PT26 (S-1)
() Black	PT27 (S-1)
() White	PT28 (NS)
() White-Green	PT31 (S-1)
() White-Blue	PT32 (S-2)
() Gray	PT33 (S-1)
() Yellow-Green	PT36 (S-1)
() Yellow-Violet	PT37 (S-1)

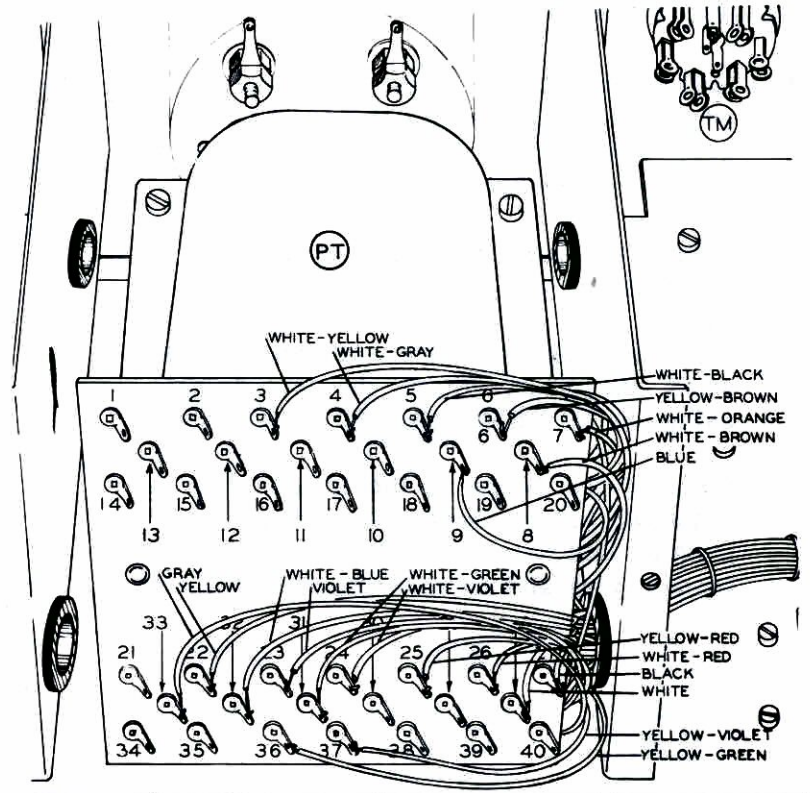

Figure 71

LEADS FARTHEST FROM BALLAST CAPACITOR (power transformer cable harness).

<u>Lead Color</u>	<u>Connect to</u>
() White	PT1 (S-1)
() Black	PT2 (S-1)
() Red	PT10 (S-1)
() Yellow-Red	PT11 (S-1)
() Yellow-Brown	PT12 (S-1)
() White-Black	PT13 (S-1)
() White-Yellow	PT14 (S-1)
() White-Orange	PT15 (S-1)
() Yellow-Green	PT16 (S-1)
() Gray	PT17 (S-1)
() Green	PT18 (S-1)
() Orange	PT19 (S-1)
() Brown	PT20 (S-1)
() Yellow-Gray	PT21 (S-1)
() White-Red	PT28 (S-3)
() Yellow	PT29 (S-1)
() White-Brown	PT30 (S-1)
() White-Violet	PT34 (S-1)
() White-Green	PT35 (S-1)
() White-Blue	PT38 (S-1)
() Violet	PT39 (S-1)
() Blue	PT40 (S-1)

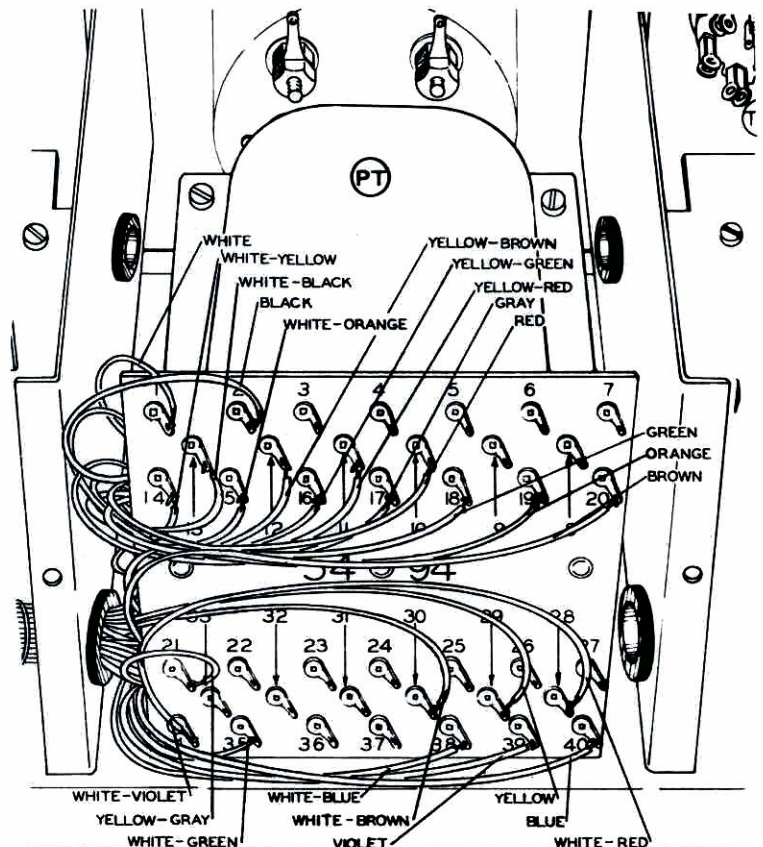

Figure 72

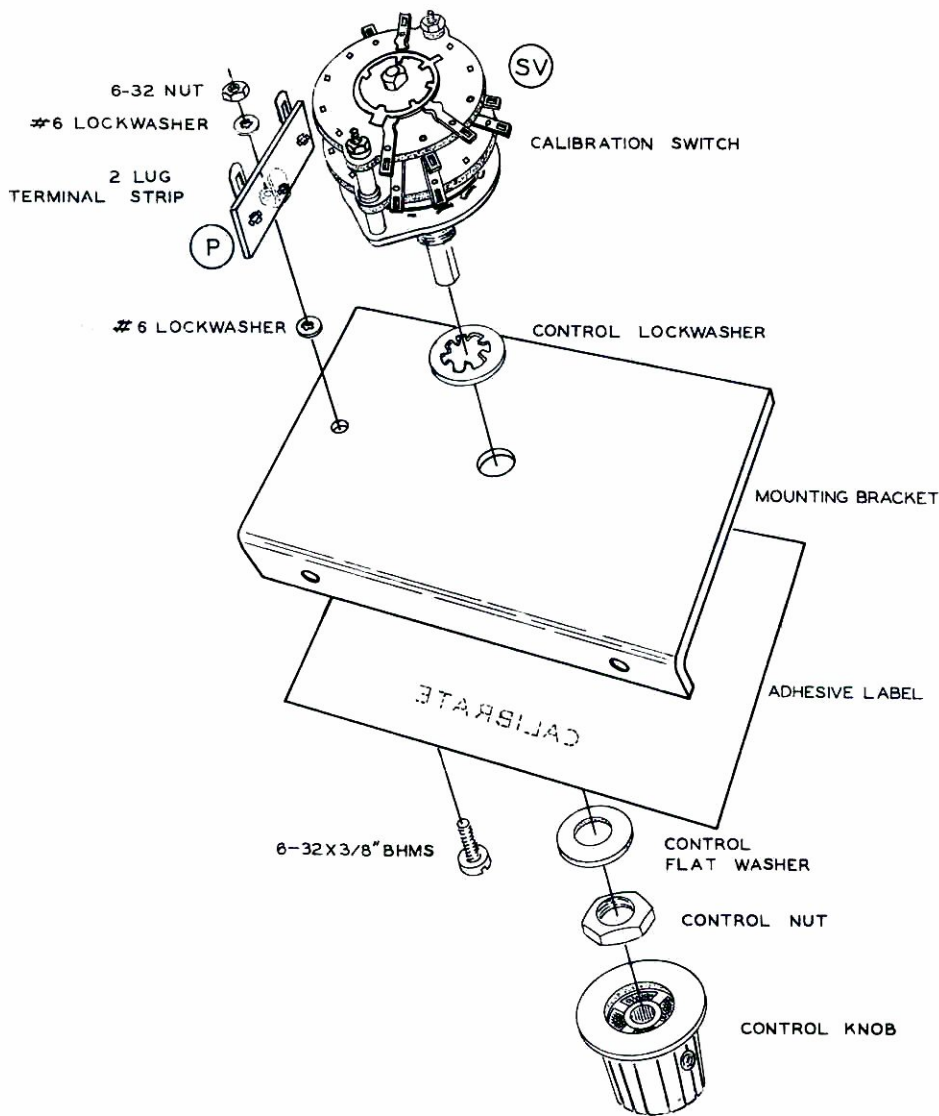

Figure 73

CALIBRATE SWITCH SUB-ASSEMBLY AND INSTALLATION

- () Strip the protective backing from the adhesive label and press it firmly onto the CALIBRATE switch mounting bracket.
- () Mount the CALIBRATE switch (#63-222) on the bracket with the #1 terminals placed toward the top of the bracket, as shown.
- () Mount the 2-lug terminal strip P, using 6-32 hardware.
- () Connect a short jumper wire from SVA1 (S-1) to SVB1 (NS). See Figure 75.
- () Connect the .22 μ fd 2% capacitor from SVA12 (S-1) to P2 (NS).
- () Using sleeving as shown, connect the 2.24 K Ω 1% resistor from SVA7 (S-1) to P1 (NS).
- () Connect the 500 Ω 1% resistor from SVB2 (S-1) to P1 (NS).

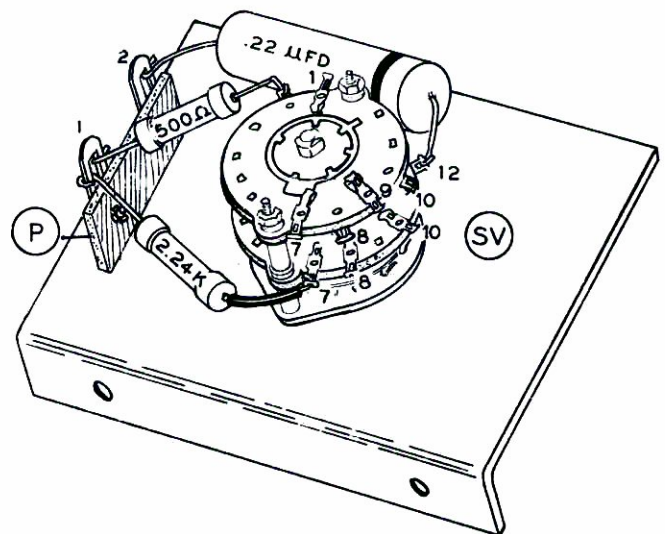

Figure 74

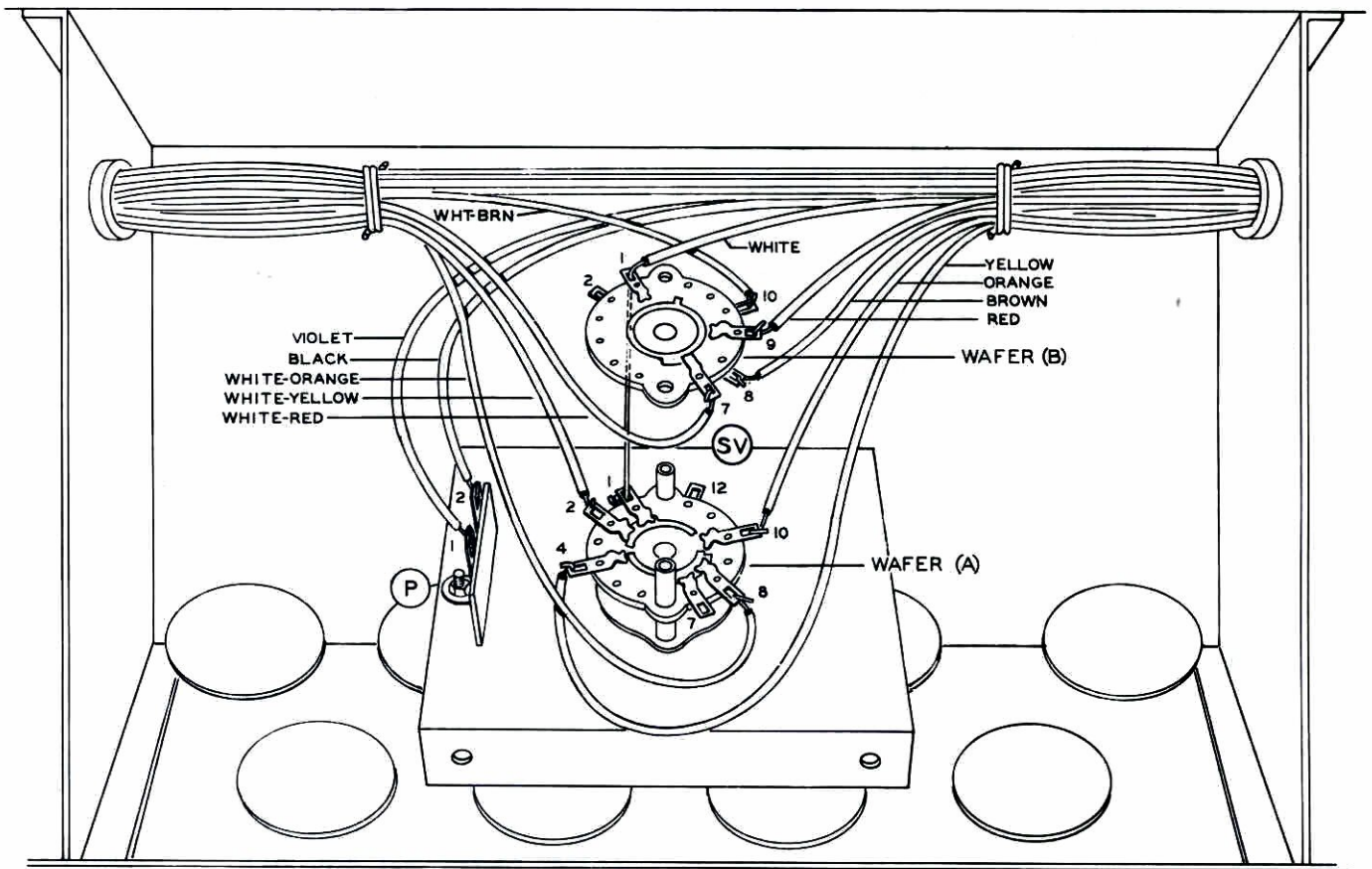
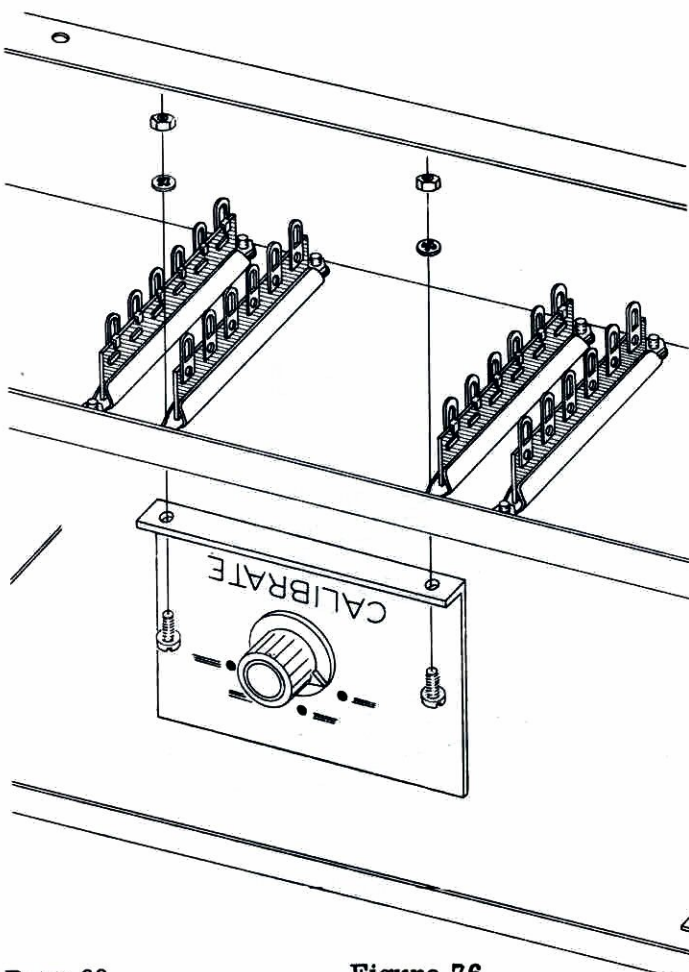

Figure 75



Connect the CALIBRATE switch leads as follows:

<u>Lead Color</u>	<u>Connect to</u>
() Black	P2 (S-2)
() Violet	P1 (S-3)
() White	SVB1 (S-2)
() Yellow	SVA4 (S-1)
() Orange	SVA10 (S-1)
() Brown	SVB8 (S-1)
() Red	SVB9 (S-1)
() White-Yellow	SVA2 (S-1)
() White-Orange	SVA8 (S-1)
() White-Red	SVB7 (S-1)
() White-Brown	SVB10 (S-1)

() Remove the two 6-32 screws holding terminal strips C and D and mount the CALIBRATE switch as shown.

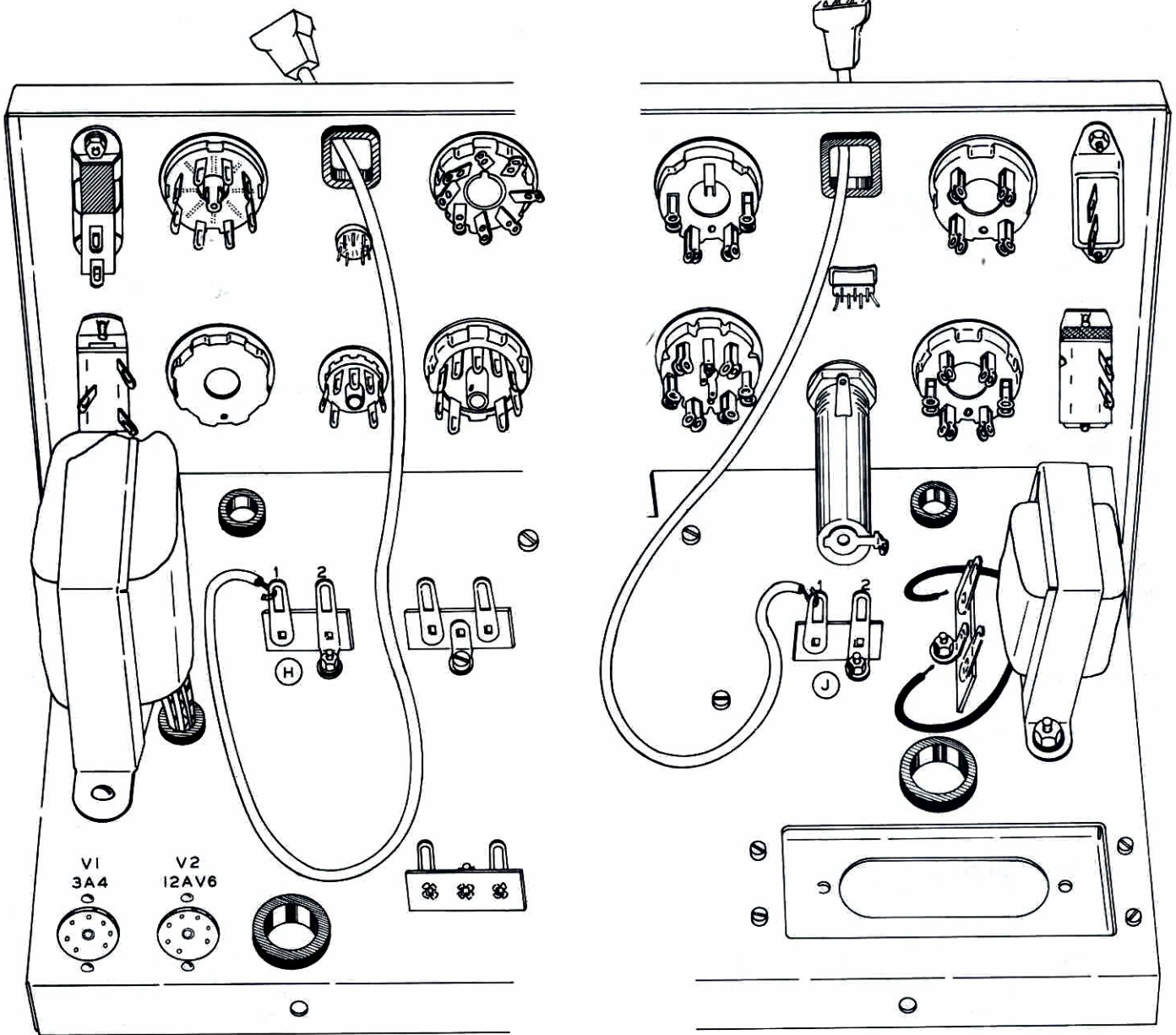

Figure 77

PULL CLIP OUT OF BAKELITE HOUSING



SOLDER ON TEST LEAD AND SLIDE CLIP BACK INTO HOUSING

() Prepare two tube cap leads as shown in Figure 77. *1-18" 1-24" long*

() Pass one lead through the square panel grommet and connect it to H1 (S-2). *18"*

() In the same manner, connect the other lead to J1 (S-2). *24"*

carefully inspect the entire assembly for stray pieces of solder and wire clippings. Also inspect each terminal to be sure that all are soldered. Should you find a terminal that is not soldered, locate the construction steps concerning that terminal; be sure the proper number of leads are connected to it before soldering.

() Install the tubes as indicated in Figure 77.

() Install the fuse in the fuse holder.

This completes the wiring of the TT-1. Before proceeding to the testing section which follows,

See TT-1A

The CALIBRATE switch should be in the OPERATE position during the testing procedure. The P, G and K switches should be in position 1. The DISCONNECT and LIFE TEST switches should be in the NORMAL position, the LEAKAGE switch in TUBE TEST position, and the PLATE switch in position D. Other switch and control positions will be called for as required. **BE SURE** to observe normal safety precautions during testing of this instrument. Disconnect power when making connections to terminals (connecting meter leads, etc.).

Ohmmeter and continuity readings may be difficult to make due to the complexity of the tube tester switching. In no case, however, should there be DC continuity shown from the circuitry to the chassis or panel. The only connection to chassis ground are the common terminals of the oscillation suppressors (P.E.C.'s). A connection between chassis and any other point indicates incorrect wiring or a faulty component.

In the event the unit does not perform as outlined in the testing procedure, troubleshooting is greatly simplified by comparing the wiring of the switches, transformer, etc. with the terminal code data shown on the Schematic Diagram.

1. LINE CONTROL CIRCUIT

Plug the line cord into a 105-125 volt 60 cycle AC source and move the OFF-ON switch to the ON position. The panel lamps should light to a normal brightness level with the SET LINE control at the halfway point of its rotation. Turning the SET LINE control clockwise from this position should brighten the panel lamps. Turning the SET LINE control counterclockwise should cause the panel lamps to dim.

Pull down the LINE TEST switch. The meter should deflect upscale. The reading of the meter will be dependent upon the position of the SET LINE control, a clockwise rotation of the control producing an increase in meter indication. Assuming an input voltage of 117 volts, the meter indication should vary from approximately 1/4" to the left of the LINE CHECK arrow at midscale (maximum counterclockwise position of SET LINE control) to about 1/2" to the right of the arrow (maximum clockwise position of the SET LINE control).

2. FILAMENT SUPPLY CIRCUIT

Connect the leads of an AC voltmeter to SX21 (see Figure 43) and CD1 (see Figure 63) (use the 150 volt range or higher). Turn the instrument ON and adjust the line voltage (pull down the LINE TEST switch and adjust the meter to the LINE CHECK arrow with the SET LINE control).

For all voltage positions of the FILAMENT switch, the voltmeter should read essentially the same voltage as that shown on the PANEL. The important consideration is that the voltmeter reading should increase with each successive clockwise step of the FILAMENT switch. If the voltmeter shows a decrease when the switch is rotated clockwise, the switch has been incorrectly wired. If this situation occurs, it should be corrected before proceeding further.

With the FILAMENT switch at any convenient voltage position, depressing the LIFE switch should decrease the voltmeter reading by approximately 10%.

Select a tube designed for series string hookup (heater current of 600 ma preferred) and set the SELECTOR switches corresponding to the heater connections to positions 6 and 7, respectively. Set all other SELECTOR switches to 0. The top row of SELECTOR switches corresponds to tube pin 1 through 5, starting at the left. The bottom row corresponds to tube pins 6 through 9, starting at the left. Turn the filament switch to the correct current position.

Now plug in the tube. It will probably be necessary to readjust the SET LINE control. The voltmeter should now indicate essentially the same voltage as that listed for the particular tube type you are using. Here again, depressing the LIFE switch should decrease the voltage reading by approximately 10%.

If everything is operating as outlined above, the filament supply circuit has been correctly wired. Remove the tube and go on to the plate voltage testing section.

3. PLATE VOLTAGE SUPPLY

Connect the leads of the AC voltmeter to SP2 and SQ2 (see Figure 29). The voltmeter should indicate as shown below for various positions of the PLATE switch.

Position A	20 V AC
Position B	45 V AC
Position E	177 V AC

Connect a DC voltmeter to SP2 and SQ2 (negative to SP2). The voltmeter should indicate as shown below for various positions of the PLATE switch.

Position O	26 V DC
Position C	90 V DC
Position D	135 V DC
Position F	225 V DC

Remove the voltmeter leads and put the PLATE switch in position G. This connects the variable DC supply used for voltage regulator testing. This supply is constantly monitored by the TT-1 meter, which should now be reading the value of the voltage applied to the plate circuit of the tester. This voltage may be varied by either the FILAMENT switch or the SET LINE control. If either one or both fails to change the value of the meter reading or if no reading is present, check the wiring of the PLATE switch and associated circuitry before proceeding.

Place the PLATE switch in position O. Connect a DC voltmeter to terminals N1 and O1 (negative to N1). The voltmeter should indicate 26 V DC. This voltage supply is connected to the space charge grid of space charge grid tubes.

4. BIAS VOLTAGE SUPPLY

Connect the leads of a DC voltmeter to SP2 and SR2 (negative SR2). Place the BIAS RANGE switch in the L (low) position and the BIAS control maximum clockwise. Turn the internal bias adjust control CD through-out its entire rotation. The voltmeter should indicate from 0 to 20 volts, depending on the setting of CD. Adjust CD to give a voltmeter reading of approximately 5 volts. Now turn the BIAS control on the front of the panel. This should vary the voltmeter reading from 0 V (maximum counterclockwise) to 5 V (maximum clockwise). Now change the BIAS RANGE switch to the H (high) position. Rotation of the BIAS control should now give a voltmeter indication from 0 to 20 volts. Remove voltmeter leads.

5. LEAKAGE TESTING CIRCUIT

Set the instrument controls as shown below. These are the settings for a 6AU6 tube.

PLATE	C
FILAMENT	6.3
SELECTORS	52763-4100
BIAS	9L
METER	45
SIGNAL	4

Select a convenient value of resistance (preferably between 100 K Ω and 500 K Ω). With this resistor between pins 4 and 7 of any of the tube sockets, the meter should indicate the resistance value directly on the LEAKAGE meter scale when the LEAKAGE switch is in the #1 position. Move the LEAKAGE switch to position 2 - the meter pointer should return to its rest position. Now move the resistor to pins 2 and 7. The resistance reading should now reappear on the meter. Check the remaining positions of the LEAKAGE switch as shown below.

<u>Switch Position</u>	<u>Resistor between</u>
3	Pins 5 and 7
4	Pins 6 and 7
5	Pins 1 and 7

If the leakage testing circuit does not operate as outlined above, recheck the wiring of the LEAKAGE switch and associated circuitry before continuing the testing procedure, otherwise, remove resistor.

NOTE: The meter pointer will normally be a little above zero with the LEAKAGE switch in position 2, 3, 4, or 5.

6. TUBE SOCKET AND SELECTOR SWITCH WIRING

Place the LEAKAGE switch in the TUBE TEST position. The other controls should be positioned as outlined in the previous section. The instrument is now set up to test a 6AU6. With the negative lead of a DC voltmeter connected to pin 7 of any of the tube sockets, you should measure the following voltages at the pin numbers indicated.

<u>PIN NO.</u>	<u>VOLTAGE</u>
1	-1 volt (approx)
2	0 volts
5	+90 volts \pm 10%
6	+90 volts \pm 10%

An AC voltmeter connected between pins 3 and 4 should indicate approximately 6 volts AC.

Operation of the DISCONNECT switch should reduce the above listed voltage readings to 0.

7. Gm TESTING CIRCUIT

Insert a 6AU6 tube which is known to be good in the proper socket and allow it to warm up (knob positions should be as indicated in Section 5). While it is heating, position the two tab mounted controls CF and CG (mounted on the subchassis) at the mid-point of rotation. The METER control should now be turned maximum counterclockwise (0).

Pull down the Gm test switch; the meter should now deflect up-scale. The meter reading should increase and decrease accordingly as CF and CG are varied. Changing the position of the SIGNAL switch should also cause a variation in meter reading, a decrease in meter reading corresponding to clockwise motion of the SIGNAL switch. This action should also occur as the METER control is varied, an increase in meter reading corresponding to clockwise rotation of the control.

If no meter reading is obtained during this test, the oscillator transformer connections, oscillator tube socket connections, oscillator tube (3A4) and choke connections could be possible sources of trouble. Remove 6AU6 tube.

8. GRID CURRENT TESTING CIRCUIT

Turn the PLATE switch to position "0". Connect a large resistance value (22 megohms or higher) from SR2 to SQ2. Turn the instrument on and allow a few minutes for the 12AV6 tube to heat.

Turn the GRID CURRENT switch to the TEST position and hold it there. The meter should deflect up-scale.

If no meter reading is observed during this test, the GRID CURRENT switch wiring and associated circuitry should be checked carefully. Remove the resistor between SR2 and SQ2 before proceeding further.

9. RECTIFIER AND DIODE TESTING CIRCUIT

Set the panel controls as shown below. These are the settings used for testing a 6AL5 tube.

PLATE	A
FILAMENT	6.3
SELECTORS	K3761 - 2P00
METER	39

Insert a 6AL5 tube which is known to be good into the proper socket. After allowing sufficient time for the tube to heat, pull down the AMPL.-RECT. and DIODES switch to the RECT and DIODES position. The meter should deflect up-scale into the section marked "DIODES O.K." Remove 6AL5 tube.

10. CALIBRATION CIRCUIT

Turn the CALIBRATE switch to position 1 (BIAS) and the BIAS controls to 20L; the meter should deflect up-scale. This meter reading should increase or decrease accordingly as CD is varied.

Turn the BIAS control to 0, change the CALIBRATE switch to position 2 (SIGNAL), and pull down the Gm test switch. The meter reading with the CALIBRATE switch in this position should change with rotation of control CG.

Turn the METER control maximum clockwise and change the CALIBRATE switch to position 3 (METER). The PLATE SWITCH should be in position C. Pull down the Gm test switch. The meter reading should vary with rotation of control CF.

Return the CALIBRATE switch to the OPERATE position.

If all circuits check out as indicated, proceed with the roll chart installation. If difficulty is encountered it will be easier to correct before the roll chart mechanism is installed.

ROLL CHART INSTALLATION

- () Remove the knob, control nut and flat washer from the LEAKAGE switch. Carefully push the switch shaft back through the panel. Now swing the switch away from the panel enough to get at the two screws holding the roll chart bracket to the sub-chassis mounting bracket.
- () Remove the eight screws holding the roll chart bracket assembly.
- () Disconnect the panel lamp sockets from the pilot lamps.
- () Lift out the roll chart bracket assembly.

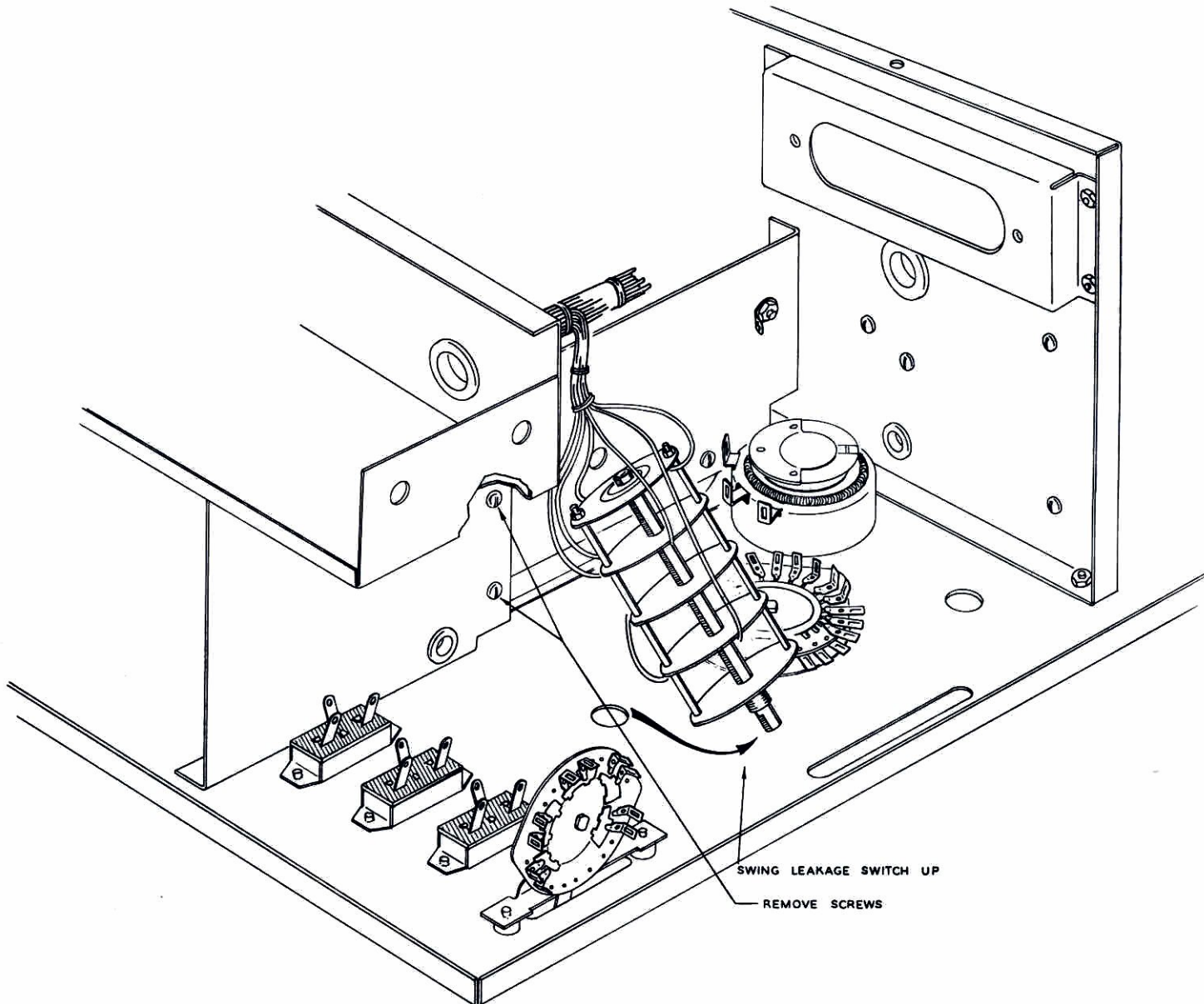

Figure 78

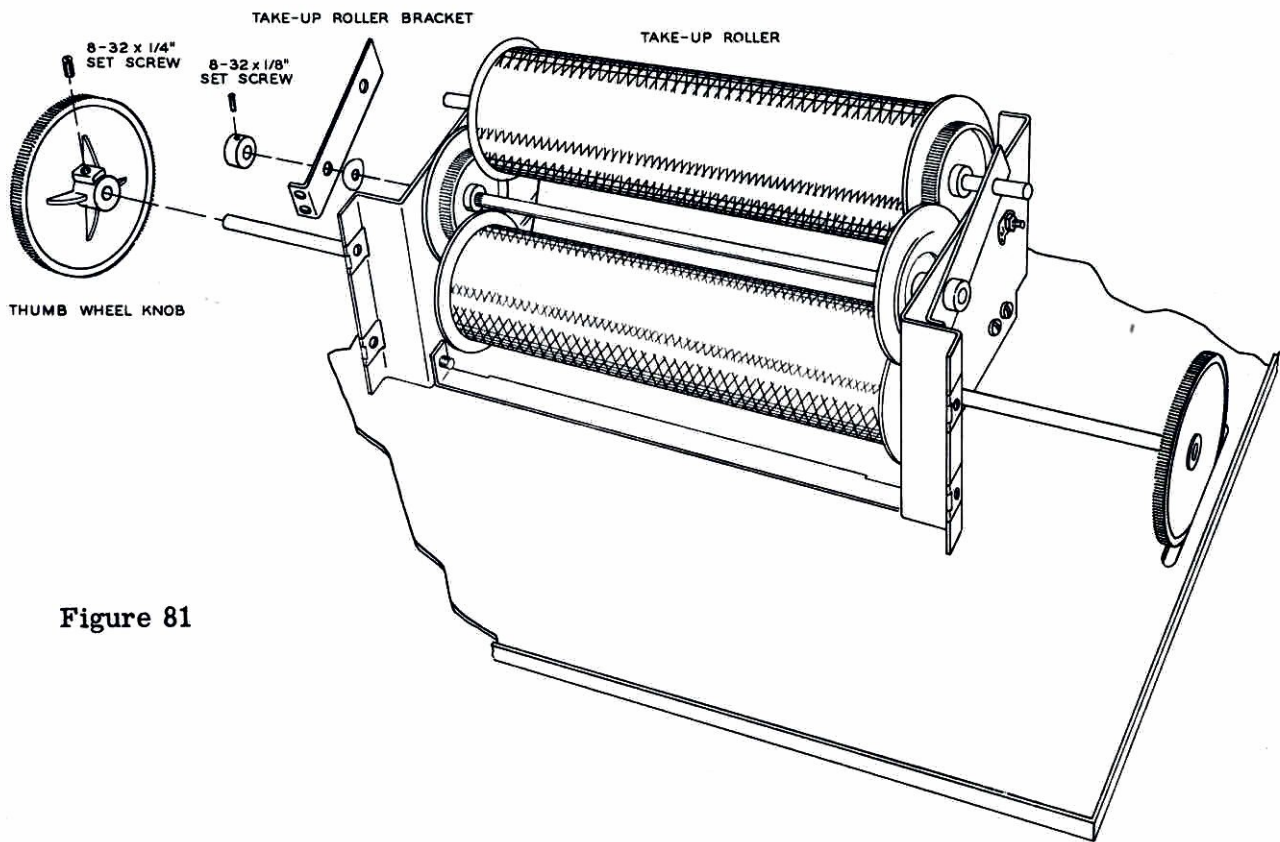

Figure 81

- () See Figure 79 and remove the right hand roll chart bracket from the assembly and install the drive roller and idler gears. Place a 1/4" retaining collar between the idler gears and a spring brass washer on each end between gear and bracket.

NOTE: Push idler gear on knurl before installing idler gear shaft. Gear should cover about 1/2 of the knurl.

- () Replace the right hand roll chart bracket.
- () Slide a 1/4" retaining collar over each end of the driver roller shaft.
- () Replace the roll chart assembly in the tube tester, following the steps as outlined in Figure 80.
- () Reinstall the pilot light sockets.
- () Center the drive roller between the roll chart brackets. Secure it in this position by sliding the retaining collars up to the brackets. The roller should rotate freely with no binding of the retaining collar against the brackets. Lubricate with ONE DROP of light machine oil on each bearing surface.
- () Center the thumb wheel drive knobs in their respective slots and tighten the setscrews.

- () Adjust the positioning of the idler gear on the KNURLED END of the idler gear shaft in such a way that:

- A. The length of shaft extending from the roll chart brackets is equal.
- B. The space between the idler gear and drive roller gear is approximately 1/64".

- () Adjust the other idler gear so that a space of 1/64" is allowed between the idler gear and the drive roller gear. Secure the gear in this position by sliding the retaining collar against the gear hub and tightening the setscrew.

- () Check to be sure the mechanism is running freely. It may be necessary to readjust the positioning of the idler gears. The objective is to retain a positive lock between gear teeth while minimizing any "scraping" condition between idler gears and drive roller gears. When the idler gears have been properly adjusted, lubricate bearings with ONE DROP of light machine oil.

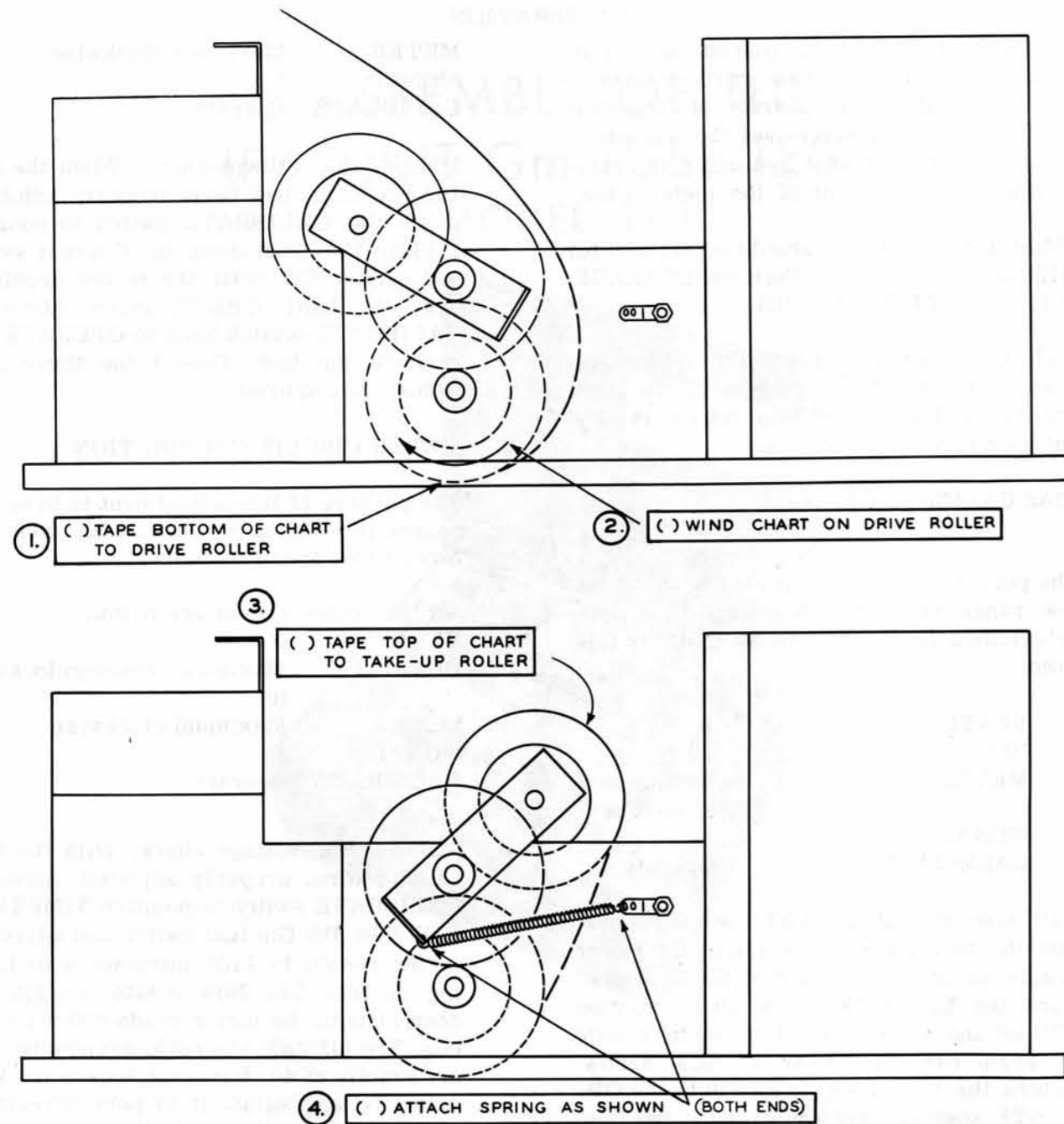

Figure 82

- () Slide a spring brass washer on each end of the idler gear shaft.
- () Lay the take-up roller on the roll chart brackets next to the chassis. Roll it toward the idler gears so that it meshes with both gears while still retaining contact with the roll chart brackets.
- () Install the take-up roller brackets and retaining collars. The retaining collars should be forced toward center just enough to allow the spring action of the washers to maintain the take-up roller brackets parallel to

the roll chart brackets. There should NOT be enough tension on these spring washers to cause binding of the mechanism.

- () Once again, check to make sure the mechanism is running smoothly before lubricating the take-up roller shaft with ONE DROP of light machine oil at each bearing.

- () Install the roll chart as directed by the steps in Figure 82.

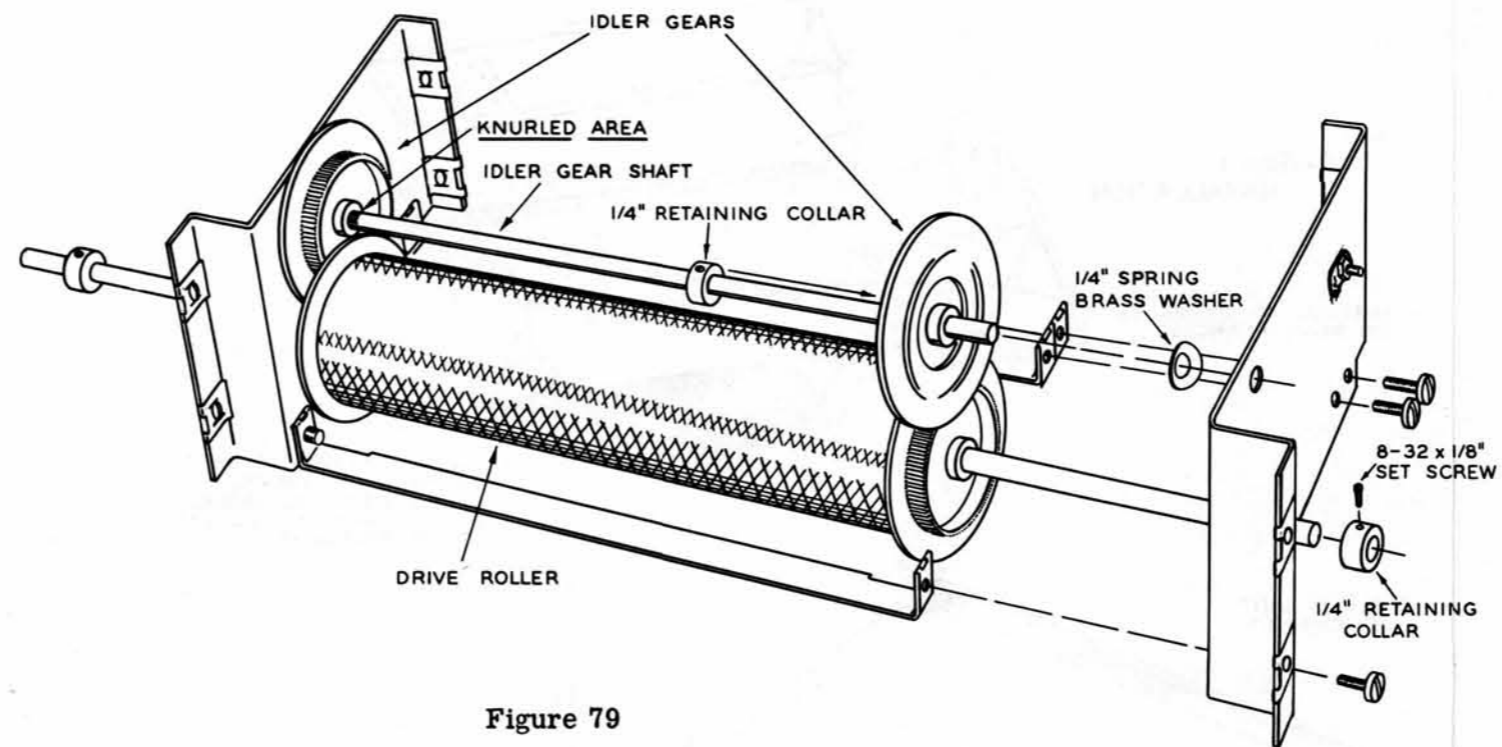

Figure 79

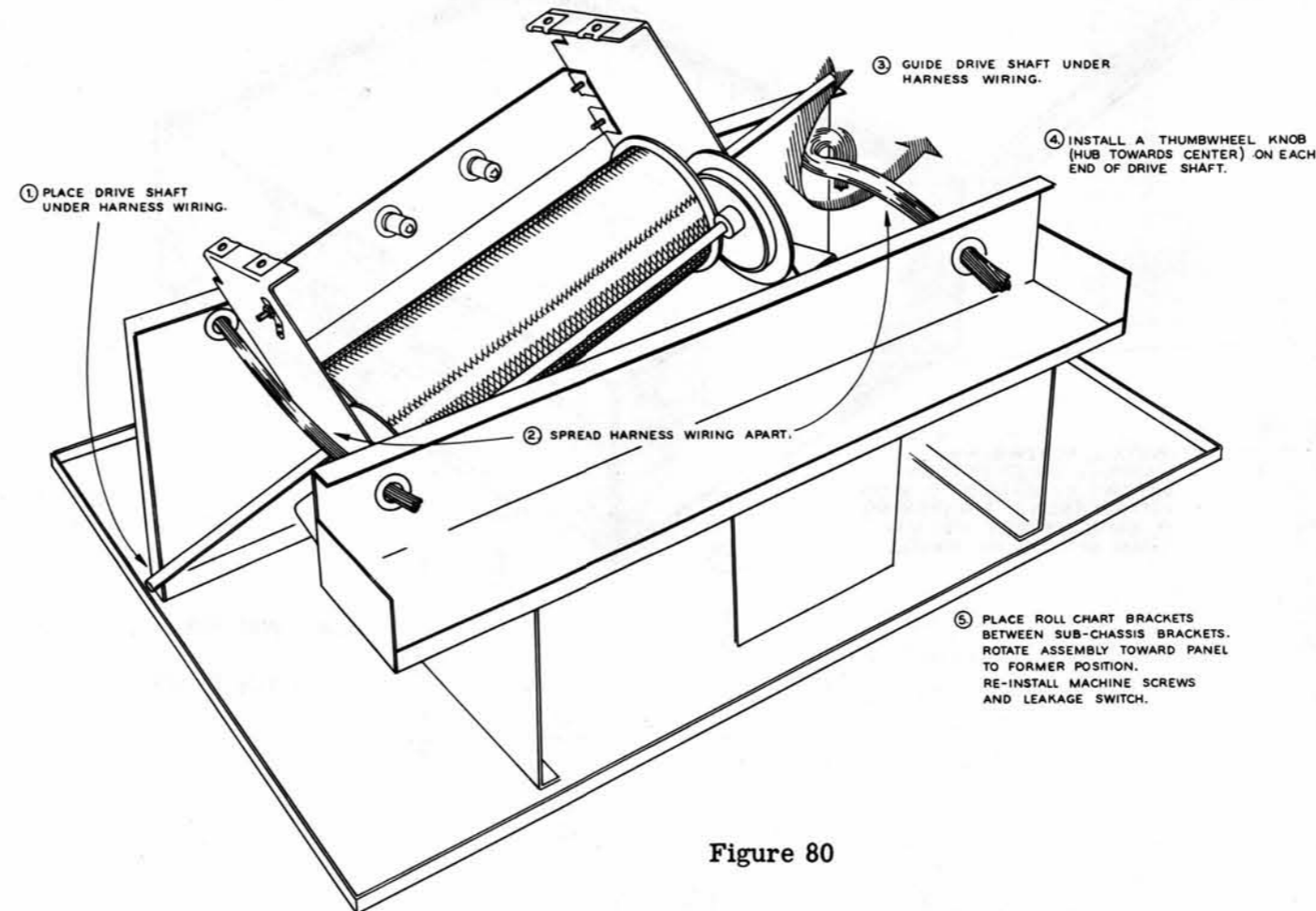

Figure 80

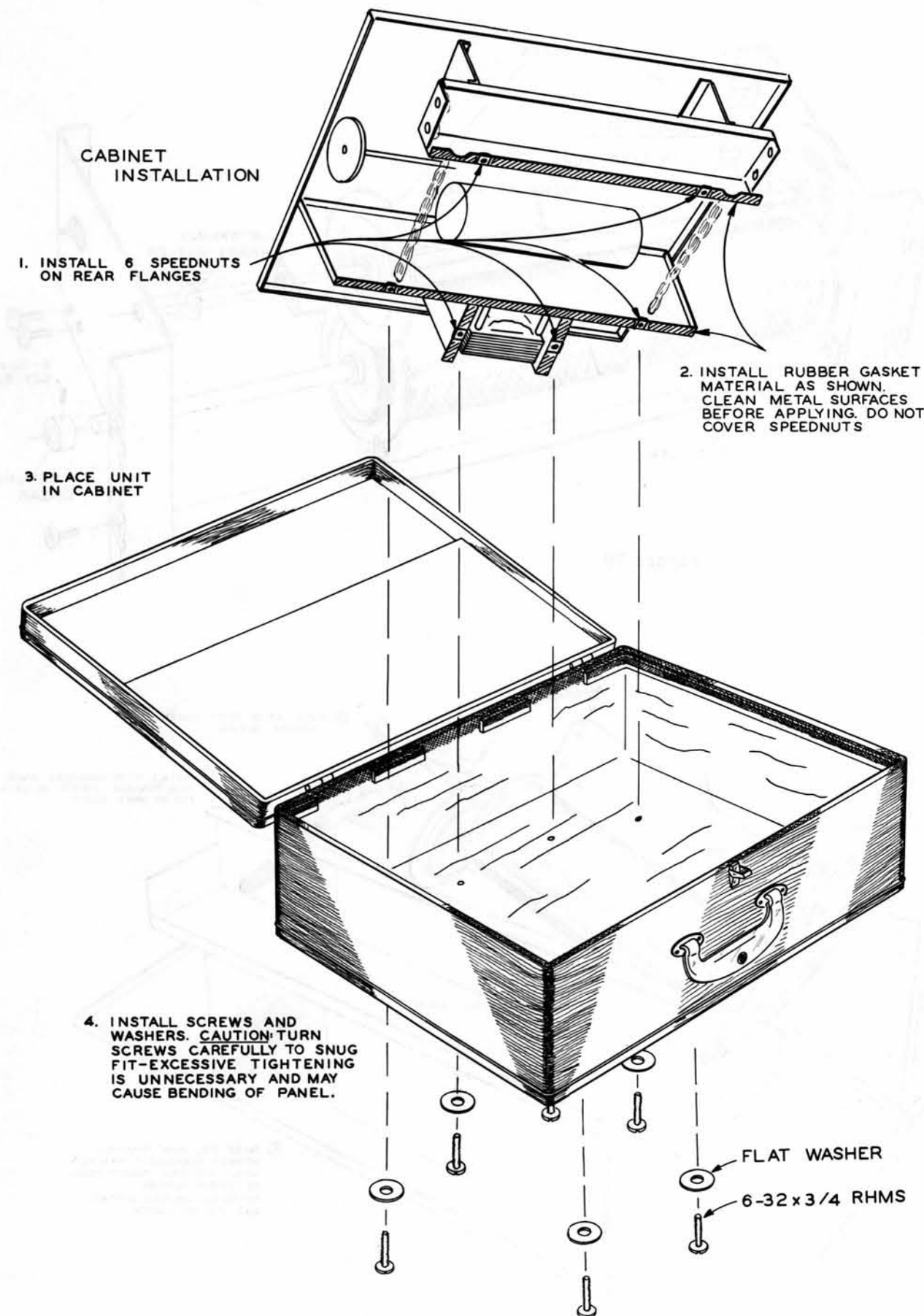

Figure 83

CALIBRATION

The instrument should be placed on a flat rigid surface. With the line cord removed, check the mechanical zero position of the meter needle. If it is not directly over the 0 position of the meter scale, adjust it by turning the zero adjust screw in the front of the meter case.

All SELECTOR switches should be set at 0 for the calibration procedure. Turn the LEAKAGE switch to the TUBE TEST position.

Make all adjustments as carefully and accurately as possible; the accuracy of the test information derived from this tester is dependent upon proper calibration.

1. BIAS CALIBRATION

The purpose of this adjustment is to set the low range of grid bias voltage to a predetermined level. Set the controls as follows:

PLATE	A
BIAS	20 L
METER	Maximum clockwise
SIGNAL	8
CALIBRATE	Operate

Pull down the LINE TEST switch and adjust the SET LINE control until the meter needle is over the LINE CHECK arrow. Turn the CALIBRATE switch to position 1 (BIAS) and adjust CD until the meter needle is again over the LINE CHECK arrow. Return the CALIBRATE switch to the OPERATE position and again check the line. If necessary, reset the SET LINE control and recheck the bias level by moving the CALIBRATE switch back to position 1. Repeat as many times as necessary.

2. SIGNAL CALIBRATION

The purpose of this adjustment is to set the output level of the oscillator circuit (signal input to Gm testing circuit).

Set the controls as follows:

PLATE	A
BIAS	Maximum counterclockwise (0)

METER	Maximum clockwise
SIGNAL	1
CALIBRATE	Operate

Make a line voltage check. When the SET LINE control has been properly adjusted, move the CALIBRATE switch to position 2 (SIGNAL). Pull down the Gm test switch and adjust CG until the meter needle is over the LINE CHECK arrow. Move the CALIBRATE switch back to OPERATE and recheck the line. Repeat the above procedure, if required.

3. METER CIRCUIT CALIBRATION

The purpose of this adjustment is to set the source impedance presented to the metering circuit to a specified value.

Set the controls as shown below:

PLATE	C
BIAS	Maximum counterclockwise (0)
METER	Maximum clockwise
SIGNAL	1
CALIBRATE	Operate

Make a line voltage check. With the SET LINE control properly adjusted, move the CALIBRATE switch to position 3 (METER). Pull down the Gm test switch and adjust the meter needle to 1100 micromhos by turning control CF. Now rotate the METER control until the meter reads 600 micromhos. The METER control knob should now be set exactly at 40. If it is not, loosen the knob setscrew and adjust it to point directly at 40. The two requirements that must be met are:













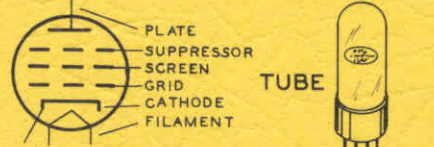





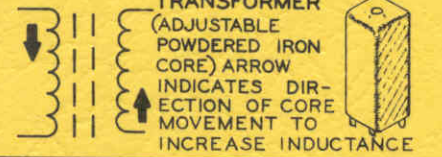
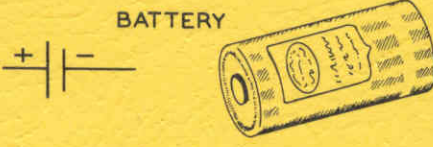

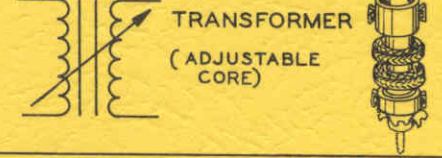

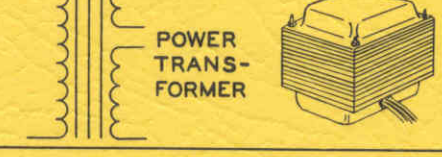

- a. The meter should indicate 1100 micromhos with the METER control turned maximum clockwise (adjust by control CF).
- b. The meter should indicate 600 micromhos with the METER control at 40 (adjust control knob).

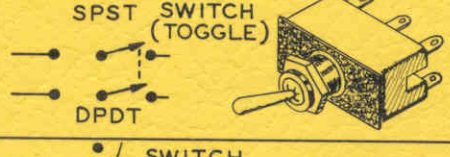
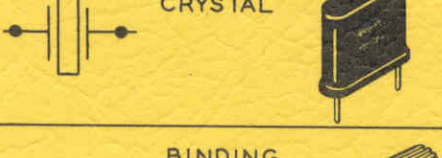
Return the CALIBRATE switch to OPERATE and recheck the line. Repeat the above procedure, if necessary.

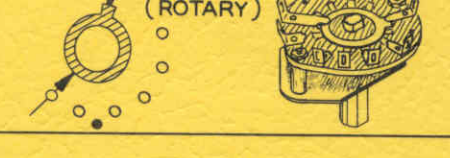
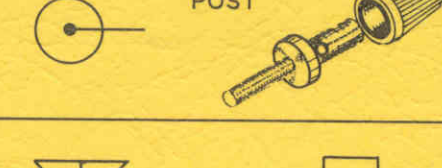
TYPICAL COMPONENT TYPES

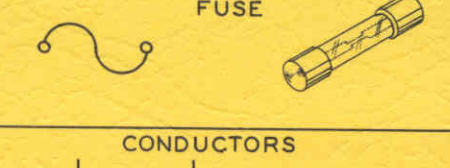
This chart is a guide to commonly used types of electronic components. The symbols and related illustrations

should prove helpful in identifying most parts and reading the schematic diagrams.

<p style="text-align: center;">RESISTOR</p> 	<p style="text-align: center;">CAPACITOR</p> 	<p style="text-align: center;">TUBE</p> 
<p style="text-align: center;">POTENTIOMETER (CONTROL)</p> 	<p style="text-align: center;">ELECTROLYTIC CAPACITOR</p> 	<p style="text-align: center;">TRANSISTOR</p> 
<p style="text-align: center;">TRANSFORMER (IRON CORE)</p> 	<p style="text-align: center;">VARIABLE CAPACITOR</p> 	<p style="text-align: center;">RECTIFIER (DIODE)</p> 
<p style="text-align: center;">TRANSFORMER (ADJUSTABLE POWDERED IRON CORE) ARROW INDICATES DIR- ECTION OF CORE MOVEMENT TO INCREASE INDUCTANCE</p> 	<p style="text-align: center;">BATTERY</p> 	<p style="text-align: center;">NEON BULB</p> 
<p style="text-align: center;">TRANSFORMER (ADJUSTABLE CORE)</p> 	<p style="text-align: center;">PHONO JACK</p> 	<p style="text-align: center;">ILLUMINATING BULB</p> 
<p style="text-align: center;">POWER TRANS- FORMER</p> 	<p style="text-align: center;">PHONE JACK</p> 	<p style="text-align: center;">METER</p> 
<p style="text-align: center;">INDUCTOR (COIL)</p> 	<p style="text-align: center;">RECEPTACLE</p> 	<p style="text-align: center;">SPST SWITCH (TOGGLE) DPDT</p> 
<p style="text-align: center;">PIEZOELECTRIC CRYSTAL</p> 	<p style="text-align: center;">SPEAKER</p> 	<p style="text-align: center;">SWITCH (ROTARY)</p> 
<p style="text-align: center;">BINDING POST</p> 	<p style="text-align: center;">MICROPHONE</p> 	<p style="text-align: center;">FUSE</p> 
<p style="text-align: center;">ANTENNA GENERAL LOOP</p> 	<p style="text-align: center;">EARTH GROUND CHASSIS GROUND</p> 	<p style="text-align: center;">CONDUCTORS NOT CONNECTED CONNECTED SHIELDED</p> 

HEATH COMPANY

BENTON HARBOR, MICHIGAN

 *a subsidiary of*
DAYSTROM, INCORPORATED

THE WORLD'S FINEST ELECTRONIC EQUIPMENT IN KIT FORM