

HEATHKIT[®] MANUAL

for the

FREEZER FAILURE ALARM

Model GD-1183

595-1912-01

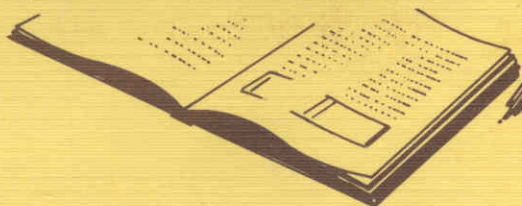

HEATH COMPANY • BENTON HARBOR, MICHIGAN

HEATH COMPANY PHONE DIRECTORY

The following telephone numbers are direct lines to the departments listed:

Kit orders and delivery information	(616) 982-3411
Credit	(616) 982-3561
Replacement Parts	(616) 982-3571

Technical Assistance Phone Numbers

8:00 A.M. to 4:30 P.M., EST, Weekdays Only

Audio	(616) 982-3310
Amateur Radio	(616) 982-3296
Test Equipment, Weather Instruments and Home Clocks	(616) 982-3315
Television	(616) 982-3307
Aircraft, Marine, Security, Scanners, Automotive, Appliances and General Products	(616) 982-3496
Computers — Hardware	(616) 982-3309
Computers — Software	(616) 982-3860
Operating Systems, Languages, Utilities	(616) 982-3860
Application Programs	(616) 982-3884

YOUR HEATHKIT 90-DAY LIMITED WARRANTY

Consumer Protection Plan for Heathkit Consumer Products

Welcome to the Heath family. We believe you will enjoy assembling your kit and will be pleased with its performance. Please read this Consumer Protection Plan carefully. It is a LIMITED WARRANTY, as defined in the U.S. Consumer Product Warranty and Federal Trade Commission Improvement Act. This warranty gives you specific legal rights, and you may also have other rights which vary from state to state.

Heath's Responsibility

PARTS — Replacements for factory defective parts will be supplied free for 90 days from date of purchase. Replacement parts are warranted for the remaining portion of the original warranty period. You can obtain warranty parts direct from Heath Company by writing or telephoning us at (616) 982-3571. And we will pay shipping charges to get those parts to you anywhere in the world.

SERVICE LABOR — For a period of 90 days from the date of purchase, any malfunction caused by defective parts or error in design will be corrected at no charge to you. You must deliver the unit at your expense to the Heath factory, any Heathkit Electronic Center (units of Venter Technology Electronics Corporation), or any of our authorized overseas distributors.

TECHNICAL CONSULTATION — You will receive free consultation on any problem you might encounter in the assembly or use of your Heathkit product. Just drop us a line or give us a call. Sorry, we cannot accept collect calls.

NOT COVERED — The correction of assembly errors, adjustments, calibration, and damage due to misuse, abuse, or negligence are not covered by the warranty. Use of corrosive solder and/or the unauthorized modification of the product or of any furnished component will void this warranty in its entirety. This warranty does not include reimbursement for inconvenience, loss of use, customer assembly, set-up time, or unauthorized service.

This warranty covers only Heath products and is not extended to other equipment or components that a customer uses in conjunction with our products.

SUCH REPAIR AND REPLACEMENT SHALL BE THE SOLE REMEDY OF THE CUSTOMER AND THERE SHALL BE NO LIABILITY ON THE PART OF HEATH FOR ANY SPECIAL, INDIRECT, INCIDENTAL OR CONSEQUENTIAL DAMAGES, INCLUDING BUT NOT LIMITED TO ANY LOSS OF BUSINESS OR PROFITS, WHETHER OR NOT FORSEEABLE.

Some states do not allow the exclusion or limitation of incidental or consequential damages, so the above limitation or exclusion may not apply to you.

Owner's Responsibility

EFFECTIVE WARRANTY DATE — Warranty begins on the date of first consumer purchase. You must supply a copy of your proof of purchase when you request warranty service or parts.

ASSEMBLY — Before seeking warranty service, you should complete the assembly by carefully following the manual instructions. Heathkit service agencies cannot complete assembly and adjustments that are customer's responsibility.

ACCESSORY EQUIPMENT — Performance malfunctions involving other non-Heath accessory equipment, (antennas, audio components, computer peripherals and software, etc.) are not covered by this warranty and are the owner's responsibility.

SHIPPING UNITS — Follow the packing instructions published in the assembly manuals. Damage due to inadequate packing cannot be repaired under warranty.

If you are not satisfied with our service (warranty or otherwise) or our products, write directly to our Director of Customer Service, Heath Company, Benton Harbor MI 49022. He will make certain your problems receive immediate, personal attention.



Heathkit® Manual

for the

FREEZER FAILURE ALARM

Model GD-1183

595-1912-01

HEATH COMPANY
BENTON HARBOR, MICHIGAN 49022

Copyright © 1976
Heath Company
All Rights Reserved
Printed in the United States of America

TABLE OF CONTENTS

Introduction	3
Assembly Notes	4
Parts List	5
Step-by-Step Assembly	
Circuit Board	8
Case Parts Mounting	12
Alarm Unit Test	14
Freezer Cable Assembly	16
Cable Assembly Test	20
Installation in Freezer	21
Final Assembly	28
Operation	29
In Case of Difficulty	32
Troubleshooting Chart	32
Specifications	34
Circuit Description	35
Semiconductor Chart	36
Circuit Board X-Ray View	36
Schematic	Illustration Booklet, Page 8
Warranty	Inside front cover
Customer Service	Inside rear cover

INTRODUCTION

The GD-1183 Freezer Failure Alarm will warn of any possible thawing of freezer contents. However, **Heath Company will not be responsible for any freezer content spoilage due to malfunction of the Freezer Failure Alarm Model GD-1183.**

The Freezer Failure Alarm performs two functions. By using a thermal switch to control the alarm switching, it warns of a failure in the freezer cooling system. Also, by using a mechanical switch to control the alarm switching, it warns when the freezer door is open. Either, or both functions, may be installed on the Freezer Failure Alarm, depending on which you prefer, by either completing or bypassing those sections in the Manual.

Other applications of the Alarm include the use of sensors to detect open doors or windows, basement flooding, or high temperatures. Included in this kit is a rain sensor that triggers the Alarm when rain contacts the sensor.

A failure of the cooling system causes the alarm to beep and a red light to flash at a slow rate. The "Door Open" feature causes the alarm to operate at a fast rate.

The GD-1183 comes with 25 feet of cable so that the Alarm Unit can be operated at a distance from the freezer. You can use additional cable length if you desire. The Alarm Unit uses two standard C-cell batteries (not supplied), which makes it ideal for campers, trailers, motor homes, and boats.

NOTE: Purchase two C-cell batteries at this time for use in the completed kit.

ASSEMBLY NOTES

1. Follow the instructions carefully and read the entire step before you perform the operation.
2. The illustrations in the Manual are called Pictorials and Details. Pictorials show the overall operation for a group of assembly steps; Details generally illustrate a single step. When you are directed to refer to a certain Pictorial "for the following steps," continue using that Pictorial until you are referred to another Pictorial for another group of steps.
3. Most kits use a separate "Illustration Booklet" that contains illustrations (Pictorials, Details, etc.) that are too large for the Assembly Manual. Keep the "Illustration Booklet" with the Assembly Manual. The illustrations in it are arranged in Pictorial number sequence.
4. Position all parts as shown in the Pictorials.
5. Solder a part or a group of parts when you are instructed to do so, or sooner if you desire.

PARTS LIST

IMPORTANT: Before you begin, make sure you read the information in the "Kit Builders Guide."

Check each part against the following list. Make a check in the space provided as you identify each part. The key numbers below correspond to the numbers on the Parts Pictorial (Illustration Booklet, Pages 1 and 2). Any part that is packed in a bag or an individual envelope with a part number on it should be placed back after you identify it until it is called for in a step. Do not throw away any packing material, bags or envelopes, until all the parts are accounted for.

Each circuit part in this kit has its own "Circuit Component Number" (R2, C4, etc.). This is a specific number for only that one part. The purpose of these numbers is to help you identify the same part in each section of the Manual.

These numbers will appear:

- In the Parts List;
- At the beginning of each step where a component is installed;
- In some illustrations;
- In the sections at the rear of the Manual.

To order a replacement part: Always include the PART NUMBER. Use the Parts Order Form furnished with the kit. If one is not available, see "Replacement Parts" inside the rear cover of the Manual. Your Warranty is located inside the front cover.

KEY No.	HEATH Part No.	QTY.	DESCRIPTION	CIRCUIT Comp. No.
------------	-------------------	------	-------------	----------------------

RESISTORS, 1/4-Watt

NOTE: The following resistors have a tolerance of 5% unless they are listed otherwise. 5% is indicated by a fourth color band of gold.

A1	6-220-12	1	22 Ω (red-red-black)	R6
A1	6-332-12	3	3300 Ω (orange-orange-red)	R3, R5, R8
A1	6-683-12	2	68 k Ω (blue-gray-orange)	R4, R7
A1	6-105-12	3	1 M Ω (brown-black-green)	R1, R2, R9

CAPACITORS

A2	21-99	2	.2 μ F ceramic	C3, C5
A3	25-880	2	10 μ F electrolytic	C1, C6
A4	27-74	2	.01 μ F Mylar*	C2, C4

*DuPont Registered Trademark

KEY No.	HEATH Part No.	QTY.	DESCRIPTION	CIRCUIT Comp. No.
---------	----------------	------	-------------	-------------------

DIODE — TRANSISTORS

NOTE: Transistors are marked for identification in one of the following four ways:

1. Part number.
2. Transistor type number.
3. Part number and transistor type number.
4. Part number with a transistor type number other than the one listed.

B1	412-616	1	LED (light emitting diode)	LED1
B2	417-235	2	2N4121 transistor	Q1, Q3
	417-801	2	MPSA20 transistor	Q2, Q4

HARDWARE

C1	250-56	2	6-32 × 1/4" screw
C2	250-175	2	2-56 × 3/8" screw
C3	250-186	8	#4 × 3/8" self-tapping screw
C4	250-347	2	#6 × 1" screw
C5	252-51	2	2-56 nut
C6	252-188	2	Push-on nut
C7	258-6	4	Battery spring
C8	259-9	4	#4 solder lug

KEY No.	HEATH Part No.	QTY.	DESCRIPTION	CIRCUIT Comp. No.
---------	----------------	------	-------------	-------------------

WIRE — CABLE — SLEEVING

	344-59	18"	White wire
D1	346-67	6"	Heat-shrinkable tubing
	347-60	25'	Cable

MISCELLANEOUS

E1	60-26	1	2-position slide switch	SW1
E2	64-23	1	Actuator switch	SW2
E3	65-63	1	Thermal switch	SW3
E4	73-92	2	Large double-stick foam tape	
E4	73-141	1	Small double-stick foam tape	
	85-1843	1	Circuit board	
	85-2621	2	Rain sensor circuit board	
E5	92-651	1	Case (top and bottom)	
E6	205-1704	1	Actuator switch plate	
	206-1241	2	Foam box halves	
E7	261-44	1	Rubber stop	
E8	354-6	3	Cable tie	
E9	401-163	1	Speaker	
E10	432-778	2	Screw terminal	



KEY HEATH QTY. DESCRIPTION
 No. Part No. _____

CIRCUIT
 Comp. No. _____

PRINTED MATERIAL

NOTE: Be sure you refer to the numbers on the blue and white label in any communications you may have about this kit with Heath Company. You may want to write the model and series numbers in this illustration for future reference.

F1	1 Blue and white label
597-260	1 Parts Order Form
597-308	1 Kit Builders Guide
	1 Manual (See Page 1 for part number.)
	Solder

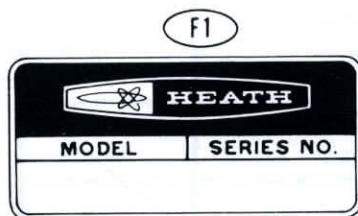

STEP BY-STEP ASSEMBLY

CIRCUIT BOARD

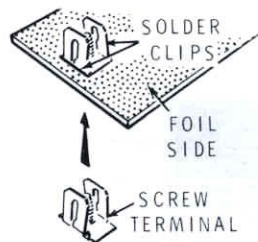
START 

- () Position the circuit board as shown and insert a screw terminal from the component side of the circuit board at hole A. Then solder each clip to the foil at the places shown. Do not get solder on the screw.

() R1: 1 M Ω (brown-black-green).

() R3: 3300 Ω (orange-orange-red).

() R2: 1 M Ω (brown-black-green).

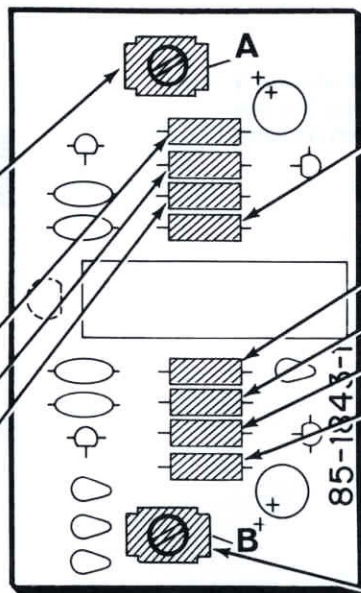

PICTORIAL 1

CONTINUE 

() R4: 68 k Ω (blue-gray-orange).

() Solder the leads to the foil and cut off the excess lead lengths.

() R5: 3300 Ω (orange-orange-red).

() R7: 68 k Ω (blue-gray-orange).

() R8: 3300 Ω (orange-orange-red).

() R6: 22 Ω (red-red-black).

() Solder the leads to the foil and cut off the excess lead lengths.

NOTE: You will have a 1 M Ω (brown-black-green) resistor left over. Put it aside temporarily. It will be used during the "Initial Test."

() Screw terminal B. Solder each clip to the foil.

START →

NOTE: When you install the following transistors, position the flat of the transistor over the outline of the flat on the circuit board. Then insert the transistor leads into their correct E, B, and C holes. Solder the leads to the foil and cut off the excess lead lengths as you install each transistor.

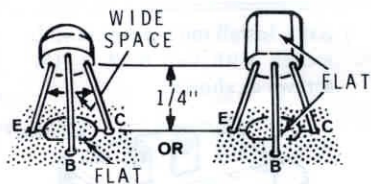

() Q1: 2N4121 transistor (#417-235).

() Q3: 2N4121 transistor (#417-235).

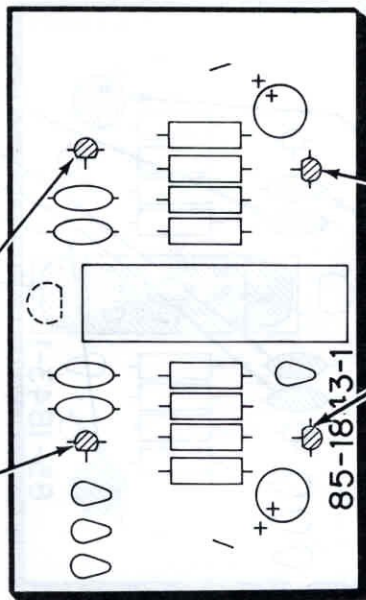

PICTORIAL 2

CONTINUE →

() Q2: MPSA20 transistor (#417-801).

() Q4: MPSA20 transistor (#417-801).

START 

NOTE: When you install electrolytic capacitors, **ALWAYS** position the plus (+) mark on the capacitor toward the plus (+) mark on the circuit board. If the capacitor has only a minus (-) mark on it, position this **away** from the plus mark on the circuit board.

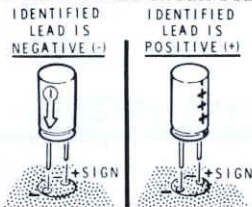

() C1: 10 μ F electrolytic.

() C2: .01 μ F Mylar.

NOTE: When you install ceramic capacitors, do not push the insulated portions of the leads into the circuit board holes. This could make it difficult to solder the leads to the foil. Solder the leads to the foil and cut off the excess lead lengths.

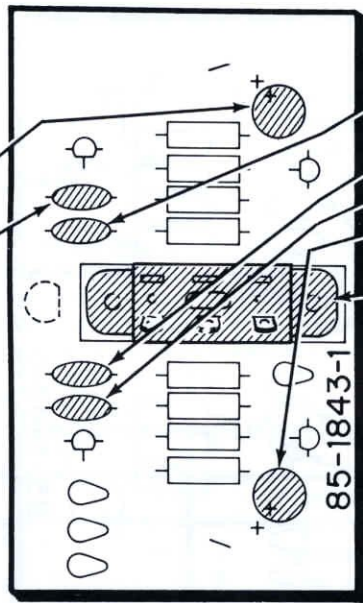

PICTORIAL 3

CONTINUE 

() C3: .2 μ F ceramic.

() C5: .2 μ F ceramic.

() C4: .01 μ F Mylar.

() C6: 10 μ F electrolytic.

() SW1: Install the 2-position slide switch with two 6-32 \times 1/4" screws as shown.

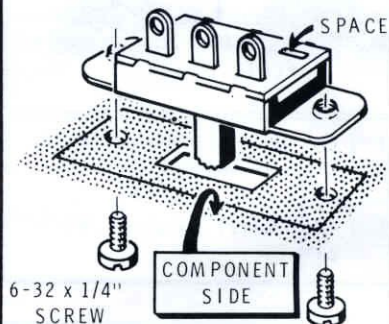

6-32 \times 1/4"
SCREW

COMPONENT
SIDE

START 

NOTE: When wiring this kit, you will be instructed to prepare lengths of wire, as in the following steps. To prepare a wire, cut it to the indicated length and remove a 1/4" of insulation from each end.

- () Prepare the following lengths of white wire:

1-1/4"
2"
2-3/4"

When you connect a wire in the following steps, insert one end into the circuit board hole and solder it to the foil. Cut off the excess lead lengths on the foil side.

- () Connect one end of a 1-1/4" wire at hole F. Connect the other end to SW1 lug 2 and solder the connection.
- () Connect a 2" wire at hole C.
- () Connect a 2-3/4" wire at hole D.

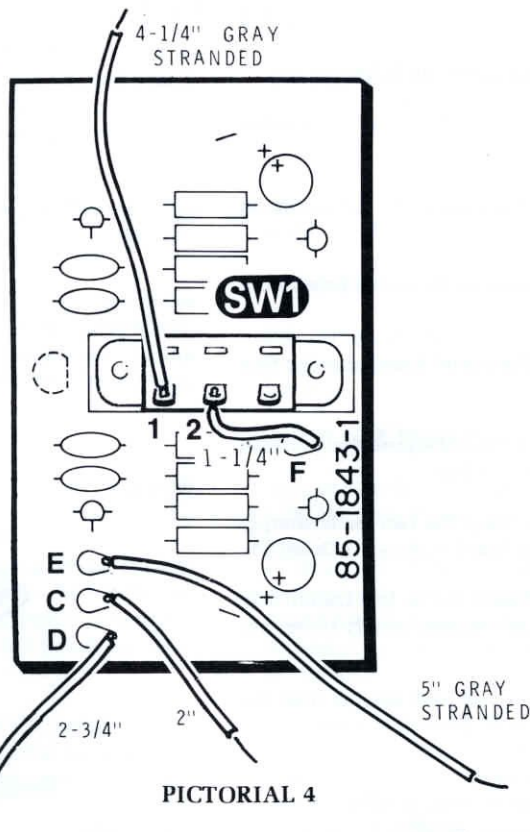
**CONTINUE** 

- () Cut a 5" length of cable and separate the wires completely.

When you prepare the following stranded wires, cut them to the proper length and remove 1/4" of insulation from each end. Then twist the strands tightly together and apply a small amount of solder to hold the strands together.

- () Prepare the following lengths of gray **stranded** wire:

4-1/4"
5"

- () Connect a 4-1/4" **stranded** wire to SW1 lug 1. Solder the connection.

- () Connect a 5" **stranded** wire to hole E. Solder the connection.

FINISH

CASE PARTS MOUNTING

Refer to Pictorial 5 (Illustration Booklet, Page 3) for the following steps.

- () Refer to Detail 5A and insert the LED leads into the circuit board in the following manner:
1. Position the LED so that the flat is the same as the flat shown on the circuit board.
 2. Insert the LED leads through the holes in the circuit board from the foil side of the circuit board.
 3. Hold the LED leads and position the circuit board over the four screw posts in the case top.
 4. Hold the circuit board firmly against the screw posts and push the LED into its mounting hole in the case top.
 5. When the LED is firmly in place, bend the two leads sharply against the printed side of the circuit board as shown in Detail 5A.
- () Refer to Detail 5B and turn the circuit board over so that the foil side faces up. Then bend the top of the LED over approximately 45 degrees and solder both leads to the foil.
- () Straighten the LED and cut off the excess lead lengths from the printed side of the circuit board.

Set the circuit board aside.

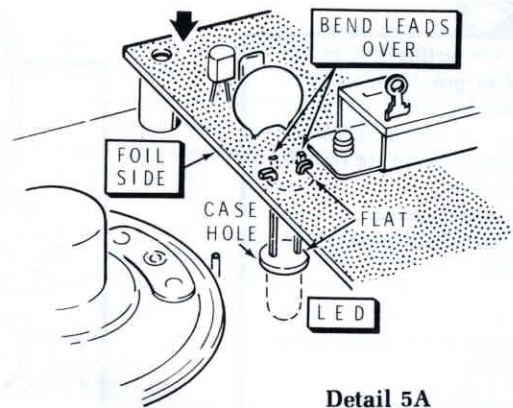

Detail 5A

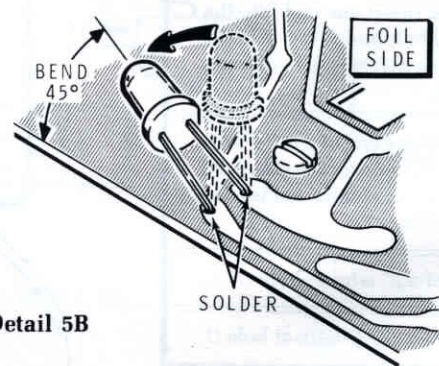

Detail 5B

CAUTION: Be careful when you handle the speaker in the following steps so you do not damage the speaker cone.

- () Place the speaker into the case top between the two small pegs and the two large mounting posts.
- () Refer to inset #1 on Pictorial 5 and squeeze a push-on nut together with your fingers.
- () Use a pair of long-nose pliers and grasp the push-on nut as shown in inset #1.
- () Slide a push-on nut over each of the mounting posts and press them firmly against the speaker.
- () For the remainder of the assembly, place two small books or magazines on your work area approximately 3" apart. Place the case top on these so that the LED is over the 3" space. This will prevent damage to the LED, which will protrude through the mounting hole in the case after the circuit board is installed.
- () Use four #4 × 3/8" self-tapping screws and install the circuit board in the case top. Make sure the LED seats in its mounting hole properly.

NOTE: In the following steps, solder each wire as you connect it.

- () Connect the wire coming from hole D to the indicated speaker terminal.

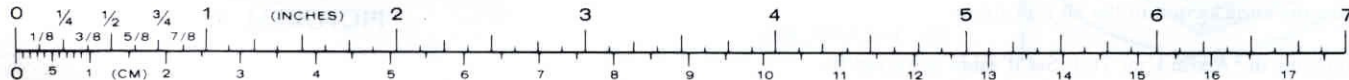

- () Connect the wire coming from hole C to the other speaker terminal.
- () Position the case bottom as shown in Pictorial 5.
- () Refer to inset #2 and install a battery spring and a #4 solder lug on each of the four screw posts with a #4 × 3/8" self-tapping screw. Do not overtighten the screws.
- () Prepare a 2" white wire.
- () Connect the 2" white wire between solder lug SP3 and solder lug SP4.
- () Position the case top and case bottom as shown.
- () Connect the 4-1/4" gray stranded wire coming from SW1 lug 1 to solder lug SP1.
- () Connect the 5" gray stranded wire coming from hole E to solder lug SP2.
- () Remove the backing paper from the blue and white label. Then apply the label to the inside of the case top as shown.

This completes the assembly of the Alarm Unit.

ALARM UNIT TEST

- () Refer to Pictorial 6 and install the batteries. Make sure you position the positive (+) ends as shown.

Refer to Pictorial 7 for the following steps.

NOTE: If the proper results are not obtained in the following steps, refer to the "In Case of Difficulty" section of the Manual.

- () Locate the 1 M Ω (brown-black-green) resistor previously set aside.
- () Place the slide switch to the ON position. See the top of the case for the correct position.
- () Refer to Part A of Pictorial 7 and grasp the resistor by the body and touch the leads to screw terminal A and lug 2 of switch SW1. The alarm should beep and the LED should flash.
- () Set the resistor aside for use in the "Freezer Cable Assembly."
- () Prepare the remaining white wire.
- () Refer to Part B of Pictorial 7 and simultaneously touch the ends of the wire to the screw terminals. The alarm should beep and the LED should flash at a faster rate than before.
- () Place the slide switch to the OFF position.

This completes the Alarm Unit Test. Set it aside temporarily.

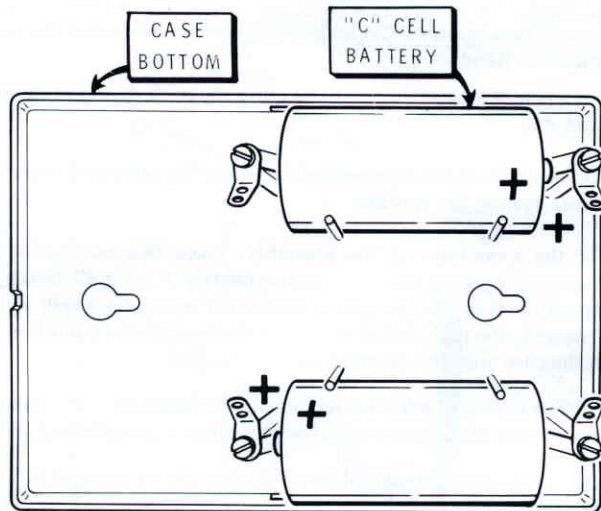

PICTORIAL 6

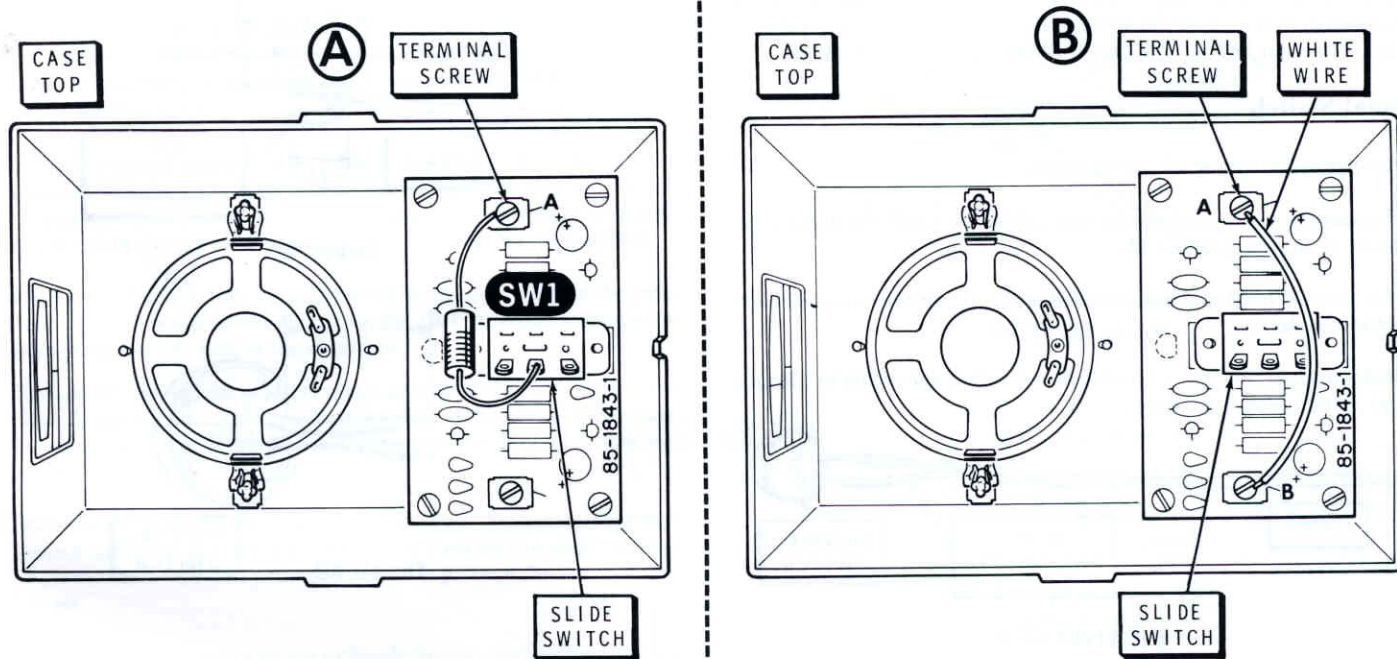

PICTORIAL 7

FREEZER CABLE ASSEMBLY

NOTE: Determine the amount of cable you will need to reach from the thermal switch to the place you will install the alarm unit. 25' of cable is supplied with your kit; but you can, if necessary, use longer cables.

Thermal Switch

Refer to Pictorial 8 for the following steps.

- () Separate the wires on the cable for a distance of 1-1/2" and prepare the ends as shown in Detail 8A.
- () Cut two 3/4" lengths of heat-shrinkable tubing and slide one over each of the leads.
- () Refer to Detail 8B and cut the leads on the thermal switch to a length of 1" and prepare the ends.

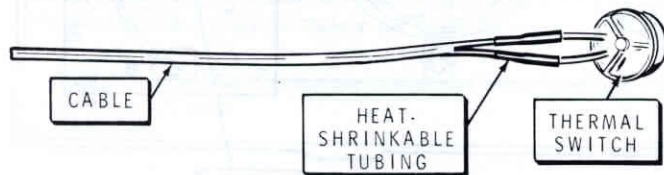

PICTORIAL 8

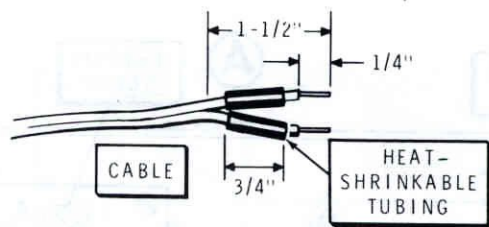

Detail 8A

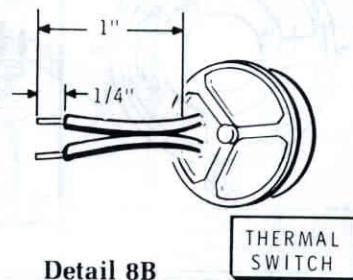

Detail 8B

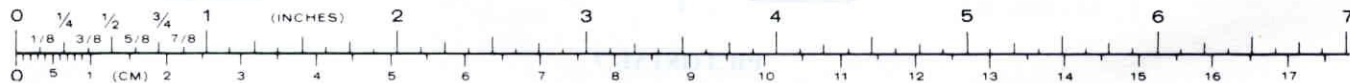

- () Refer to Detail 8C and hook one lead of the thermal switch to one wire on the cable. Squeeze the ends together and solder the connection.
- () Hook the remaining thermal switch lead to the other cable wire and solder the connection.
- () Slide both lengths of heat-shrinkable tubing over the connections.

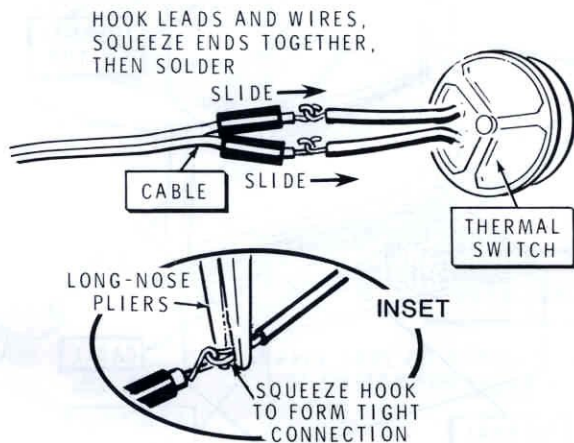

Detail 8C

CAUTION: In the following steps, be careful not to overheat the heat-shrinkable tubing.

- () Use the heat from a candle, lighter, or match and shrink the tubing in place as shown in Detail 8D.

NOTE: If you intend to use the alarm only to detect a failure in your freezer's cooling system and do not desire the "door open" alarm feature, proceed to "Installation in Freezer" on Page 21.

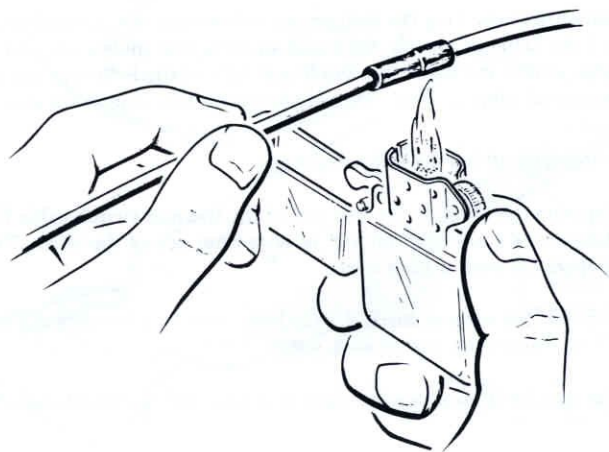

Detail 8D

Door Actuator Switch

- () Place the thermal switch and cable inside your freezer and determine the best route between the thermal switch and the actuator switch. If possible, keep the thermal switch at the center of the freezer as shown in Pictorial 9A and 9B.

Refer to Part A of Pictorial 9 if you have an upright freezer, or refer to Part B of Pictorial 9 if you have a chest type freezer.

- () Determine how long the cable must be between the thermal switch and the actuator switch; then add an extra few inches and cut the cable where the actuator switch will be installed. Return the two lengths of cable and the thermal switch back to your work area.

Refer to Pictorial 10 for the following steps.

- () Separate the wires at the free end of the thermal switch cable for a distance of 2-3/4". Cut off 1/2" of wire from one of the wires. Then prepare the end of each wire.
- () Separate the wires at one end of the long cable for a distance of 2-3/4". Then prepare the end of each wire.
- () Cut one 1-1/2" and one 3/4" length of heat-shrinkable tubing.

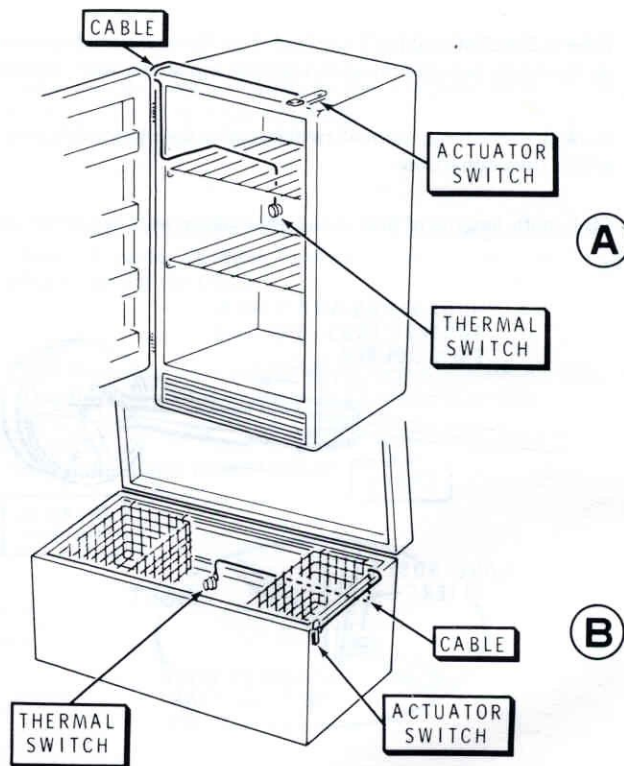

PICTORIAL 9

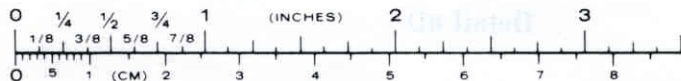

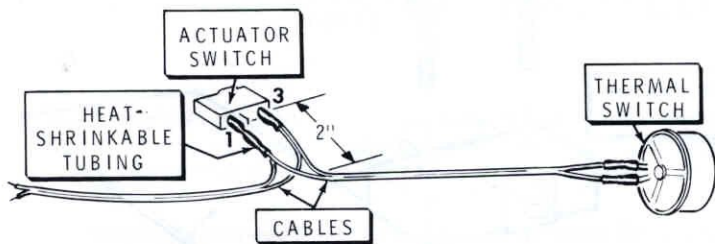

PICTORIAL 10

- () Hold the prepared cable ends and form two pairs of wires from the four wire ends. Form a hook on the four wire ends. Make sure the wire pairs are not from the same cable.
- () Slide the 1-1/2" length of heat-shrinkable tubing over the short wire from the thermal switch and one wire from the long cable.
- () Slide the 3/4" length of heat-shrinkable tubing over the two remaining wires.
- () Refer to Detail 10A and cut both leads of the 1 M Ω (brown-black-green) resistor, which you set aside earlier, to a length of 1/4" and form a hook at each end.
- () Connect one end of the resistor to lug 1 of the actuator switch. Do not solder the connection.

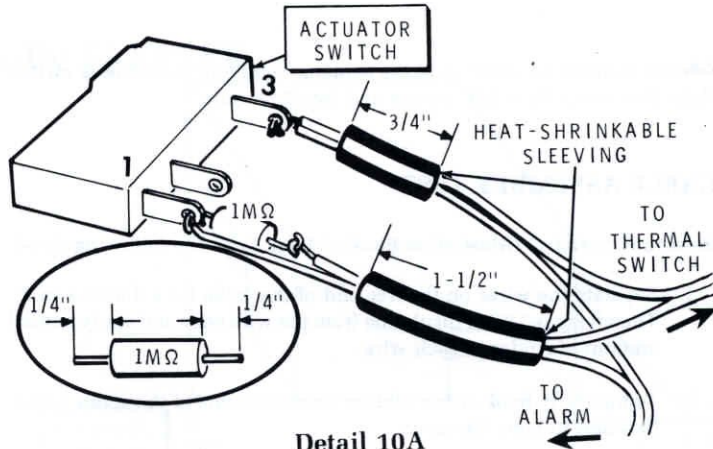

Detail 10A

- () Connect the long cable wire coming from the 1-1/2" length of heat-shrinkable tubing, to lug 1 of the actuator switch. Solder the connection.
- () Connect the remaining wire to the free end of the resistor. Squeeze the hooked ends together and solder the connection.
- () Connect the remaining pair of wires with the 3/4" length of heat-shrinkable tubing to lug 3 of the actuator switch. Solder the connection.
- () Slide both lengths of heat-shrinkable tubing over the actuator switch lugs and shrink them in place.

Refer to Pictorial 11 and mount the actuator switch to the actuator switch plate. Use two 2-56 \times 3/8" screws and two 2-56 nuts.

CABLE ASSEMBLY TEST

Refer to Pictorial 12 (Illustration Booklet, Page 4) for the following steps.

- () Separate the wires on the free end of the cable for a distance of 2". Then remove 1/2" of insulation from the wire ends and apply a small amount of solder to each wire.
- () Temporarily hook either cable wire around one of the screw terminals and tighten the screw.
- () Complete the same step for the remaining wire at the other screw terminal.

NOTE: If you do not obtain the proper results in the following steps, check your cable wiring for poor connections or shorts.

- () Place the slide switch to the ON position. The alarm should operate at the fast rate.

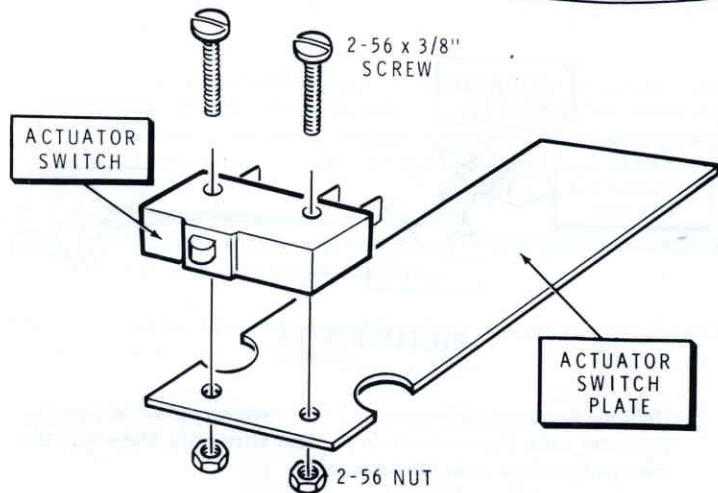

PICTORIAL 11

- () Push in on the actuator switch button and the alarm should go to the slow rate.
- () Place the slide switch to the OFF position.



INSTALLATION IN FREEZER

If your freezer is an automatic defrost type, perform the following step. If it is a manual defrost type, disregard the step. The foam box prevents the rise in temperature during the defrost cycle from turning the Alarm Unit on.

- () Refer to Figure 1 and install the thermal switch inside the foam box half. Route the cable as shown through the slot. Then install the other half of the foam box and secure both halves with freezer tape or a rubber band.

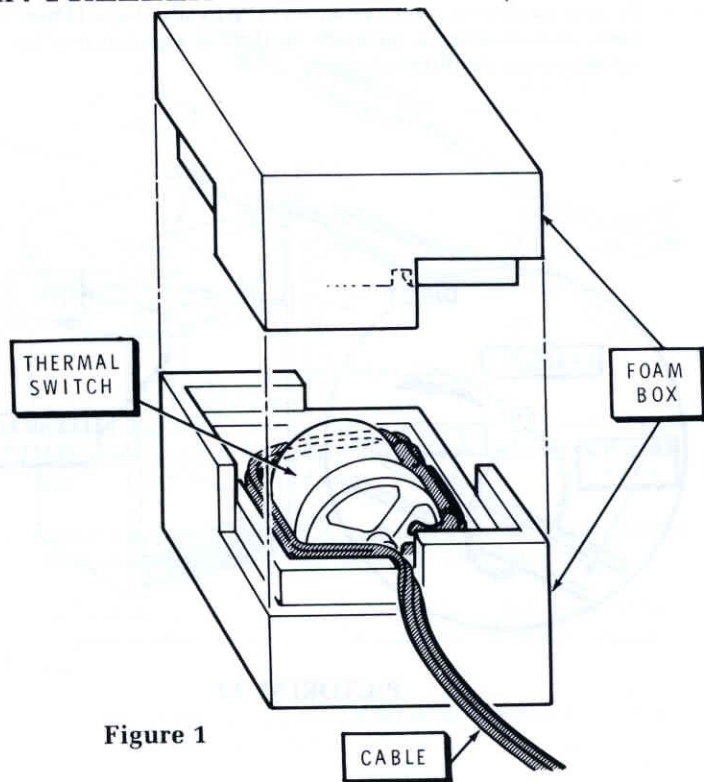
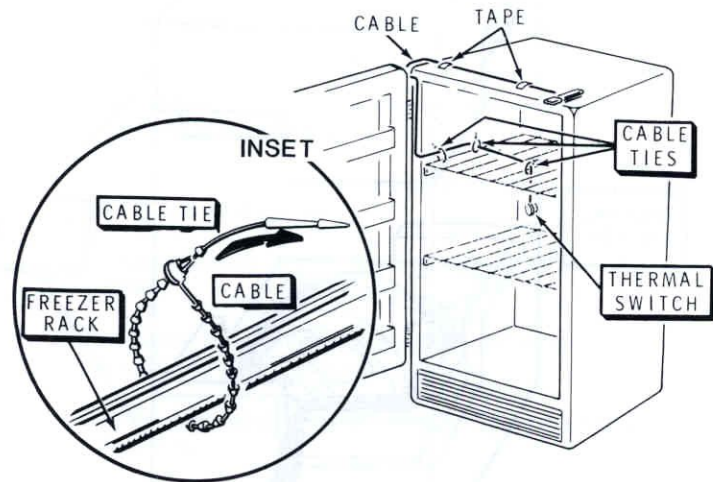

Figure 1

- () Position the thermal switch as shown in Pictorials 13 and 14 near the center of the freezer. Do not touch the thermal switch against any of the objects inside of the freezer.



PICTORIAL 13

- () Route the cable along the edge of the freezer rack and secure it with the cable ties. Then bring the cable to the outside of the freezer over the top hinge as shown in Pictorial 13 or near the rear hinge as shown in Pictorial 14. This area provides the best seal between the cable and the freezer.
- () Tape the cable to the freezer with adhesive tape. Route it to the place you will install the actuator switch.

NOTE: Proceed to "Alarm Unit Installation" on Page 26 if you do not desire the Door Actuator switch function.

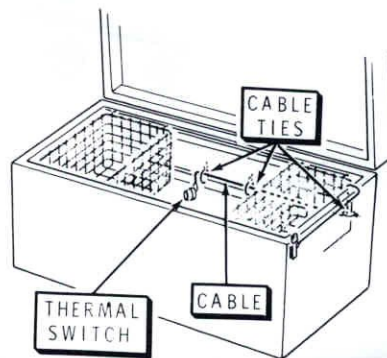

PICTORIAL 14

NOTE: Some freezers have doors which are flush with the freezer as in Pictorial 17 (in the Illustration Booklet), and others have doors which are offset as in Pictorial 18. If your freezer door is flush, or offset no more than 1/8" at the place where the actuator switch is to be installed, refer to Pictorial 15 for the following steps. If your freezer door is offset more than 1/8", refer to Pictorial 16 for the following steps.

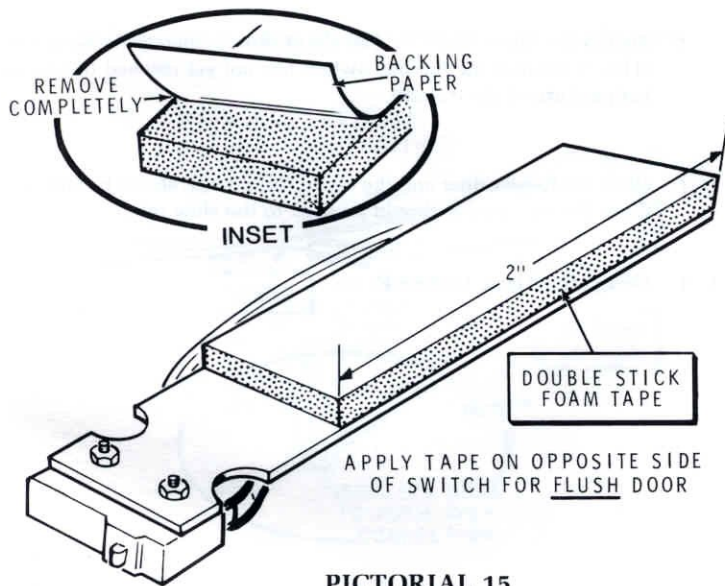

PICTORIAL 15

- () Cut a 2" length of double-stick foam tape. (Save the excess length in case the actuator switch is ever moved to another freezer.) Then completely remove the backing paper from only one side, as shown in the inset.
- () Apply the tape to the indicated side (depending on whether the door is offset or flush) of the actuator switch plate.

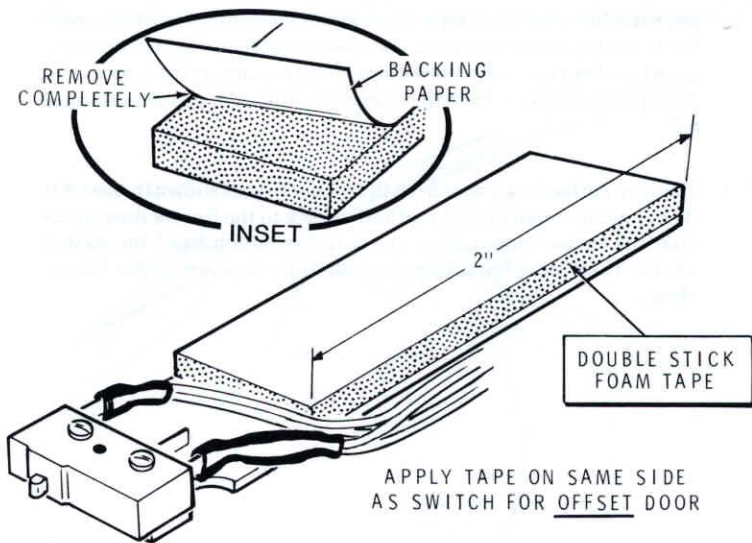

PICTORIAL 16

For the following steps, refer to Pictorial 17 (Illustration Booklet, Page 5) for actuator switch mounting on flush door type freezers and Pictorial 18 (Illustration Booklet, Page 6) for offset door type freezers.

- () Completely remove the backing paper from the remaining side of the large double-stick foam tape. Then apply the actuator switch assembly to the top of the freezer so that the door actuator switch button is positioned approximately one-third of the way across the freezer door and approximately 1" from the edge of the freezer opposite the hinged side.
- () Remove the backing paper from the rubber stop as shown in inset #1. Then, without touching the adhesive back to the freezer door, position the rubber stop against the actuator button until the switch clicks. Then press the rubber stop carefully in place on the freezer door.

- () Make sure the actuator switch button contacts the rubber stop as shown in inset 2. If it does not, bend the actuator switch plate down until it makes proper contact.
- () Switch the Alarm Unit ON. The alarm should operate at a slow rate. (This is because the thermal switch has not yet reached the inside temperature of the freezer).
- () Open the freezer door and the alarm should operate at the fast rate. Close the door and it should go back to the slow rate.
- () Switch the Alarm Unit OFF.

RAIN ALARM

One or more rain sensors can be placed on window sills or patio door jambs where rain is likely to enter. Determine the best location for your sensor(s) and provide enough 2-wire cable to run from sensor to the alarm unit. Then perform the following steps.

- () Prepare one end of the 2-wire cable as shown in Detail 19A. First separate the cable wires for a distance of 1". Then remove 1/4" of insulation from the end of each wire. Twist the end of each wire and apply a thin film of solder to hold the fine wire strands together.
- () Connect and solder the two cable wires to the two holes in the rain sensor circuit board as shown in Pictorial 19. Cut off any excess wire ends from the foil side of the circuit board.
- () Remove the paper backing from one side of a small double-stick foam tape. Then press the tape onto the plain side of the rain sensor circuit board as shown in Pictorial 19. The copper foils must be fully exposed.
- () Refer to Pictorial 20 (Illustration Booklet, Page 7) to install the rain sensor on a window sill or patio door jamb. Remove the paper backing from the foam tape and press the sensor in place at the location you chose.
- () Route the cable from the sensor to the alarm unit, and connect the two wires to the terminals on the alarm unit.

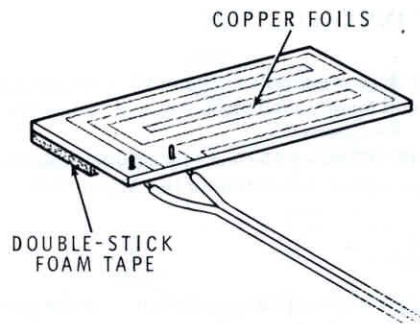

PICTORIAL 19

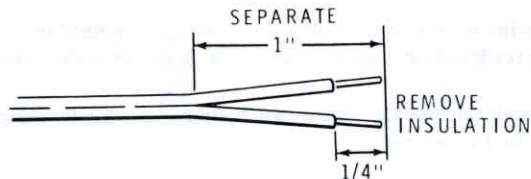

Detail 19A

ALARM UNIT INSTALLATION

- () Route the cable, as previously determined, from the actuator switch or sensor circuit board to the place you will install the Alarm Unit.

NOTE: Use either the following Method 1 for a screw mount installation or Method 2 for a tape mount installation of the Alarm Unit.

Method 1

- () Remove the case top from the case bottom. Use the case bottom as a template and mark the keyhole locations on the mounting surface with a pencil as shown in Pictorial 21.
- () Drill two 1/16" holes at the keyhole locations.
- () Screw the #6 × 1" screws into the mounting holes until the bottom of the screwheads are approximately 1/8" from the wall surface.
- () Re-install the case top on the case bottom and hang the Alarm Unit from the two screws.

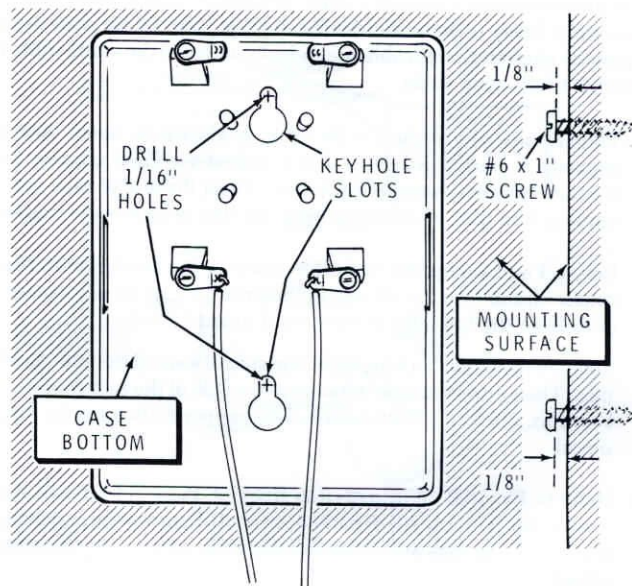

PICTORIAL 21



Method 2

- () Cut the remaining 5" length of double-stick foam tape into two 2-1/2" lengths.
- () Completely remove the backing paper from only one side of both 2-1/2" lengths of large double-stick foam tape as shown in the inset; then apply them to the back of the case bottom across both keyhole slots as shown in Pictorial 22.
- () Peel the remaining backing paper from the two lengths of large double-stick foam tape and press the Alarm Unit to the mounting surface.

This completes the "Installation."

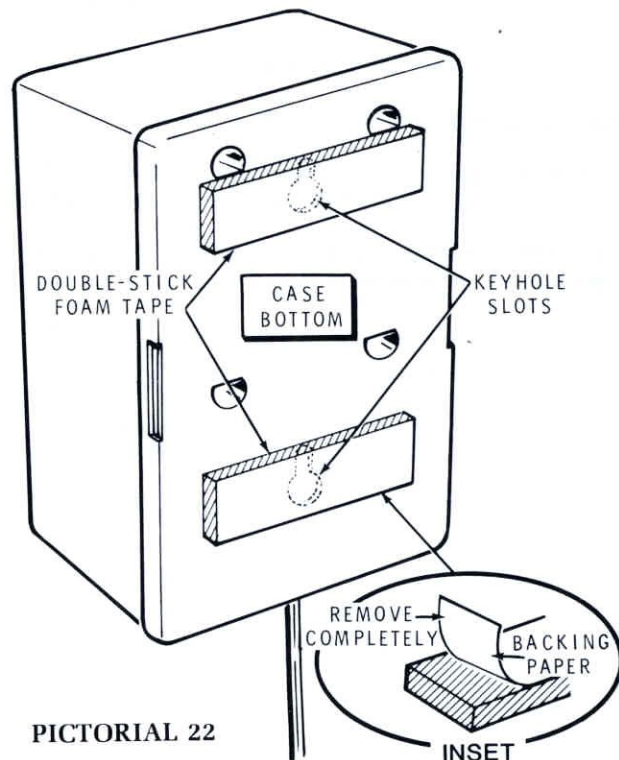

FINAL ASSEMBLY

Refer to Pictorial 23 for the following steps.

- () Route the cable through the notch in the case top.
- () Position the case top over the case bottom and squeeze the sides together so that the tabs fit inside the case bottom opposite the slots.
- () Release the sides of the case top and the tabs will slide into the slots. Make sure that no wires are binding around the case halves.

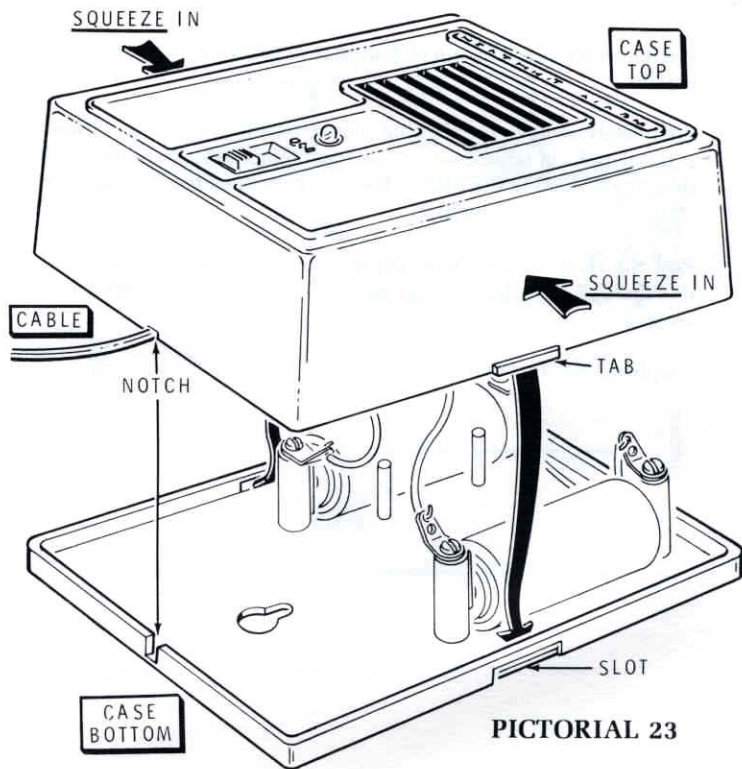



OPERATION

The GD-1183 Freezer Failure Alarm is intended to alert the owner of an impending loss of the contents inside the freezer. **HEATH COMPANY WILL NOT BE RESPONSIBLE FOR ANY FREEZER CONTENT SPOILAGE DUE TO MALFUNCTION OF THE FREEZER ALARM MODEL GD-1183.**

After the switches have been installed, the alarm will operate whenever the temperature inside the freezer rises above a nominal 20°F, or whenever the freezer door is open.

The thermal switch detects temperature changes inside the freezer. If the surrounding temperature inside the freezer is above 20°F, the switch contacts will close and the Alarm Unit will operate at a slow rate. As the temperature inside the freezer goes below a nominal 10°F, the contacts open and the Alarm Unit will not operate.

During a freezer failure, the slow-rate alarm draws only about 10 mA of current. Therefore, the alarm will sound for several days, if necessary, with fresh batteries.

It takes approximately 15 minutes for the thermal switch temperature to reach the inside temperature of the freezer. Therefore, turn the Alarm Unit off when you first install the thermal switch inside your freezer. After about 15 minutes, turn the Alarm Unit on. If the alarm does not sound, leave the switch in the ON position.

If your freezer has an automatic defrost feature, install the thermal switch inside the foam box. This foam box will insulate the thermal switch so that its temperature will rise slowly when the temperature inside the freezer rises above 20°F during the defrost cycle. The contacts on the thermal switch will remain open due to the insulation of the foam. Therefore, the

alarm will remain off during the defrost cycle. If it does not remain off, move the thermal switch to another location inside the freezer that does not warm up as much.

The "Door Open" actuator switch is a mechanical switch whose contacts are normally closed. The contacts remain closed whenever the freezer door is open and the alarm will operate at a fast rate. When the freezer door is closed, the rubber stop presses against a control button on the actuator switch which opens the contacts and turns the alarm off.

You can use the fast-rate alarm to check the condition of your batteries. If the alarm beeps at a steady tone and the LED remains lit, replace the batteries.

APPLICATIONS

This section shows several different applications for the Alarm Unit of the GD-1183. The Alarm Unit operates when the appropriate sensors are used.

A sensor can be thought of as a switch that is actuated by a mechanical linkage or by physical action. You can use any sensor that produces a closed-circuit situation to activate the Alarm Unit. The Alarm Unit is non-latching. That is, whenever the condition causing the warning to occur is corrected, the warning signal will stop.

Pictorials 24 through 27 show some of the types of sensors which you can use with the Alarm Unit. You can purchase the sensors shown from Heath Company. The Heath part numbers are given next to each sensor. You can obtain other suitable types of sensors from electronics supply stores or catalogs for different purposes.

NOTE: The mechanical actuator switch (#65-23) in Pictorials 24 and 25 has a normally open lug marked (NO), a normally closed lug marked (NC), and a common lug marked (COM). Use the NC and COM lugs for a normally-closed operation and the NO and COM lugs for a normally-open operation.

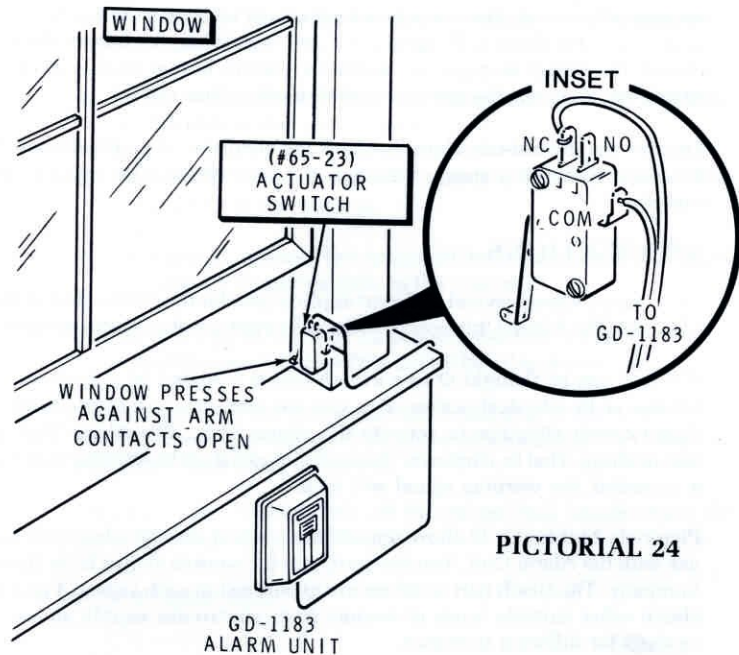

Pictorial 24 shows a window-open alarm, which uses a mechanical actuator switch connected so that the contacts are normally closed. The actuator switch is installed on the window jamb so that when the window is closed, it presses against the actuator arm and the contacts open, turning the Alarm Unit off. However, when the window opens, the switch contacts will close and the alarm will operate.

The application in Pictorial 25 uses the same mechanical switch as above. However, it is connected so that the contacts are normally open, which keeps the alarm turned off. The Bilge Alarm works as follows: as the water level rises, the float contacts the actuator arm and pushes it against the actuator switch button, which closes the contacts and operates the Alarm Unit.

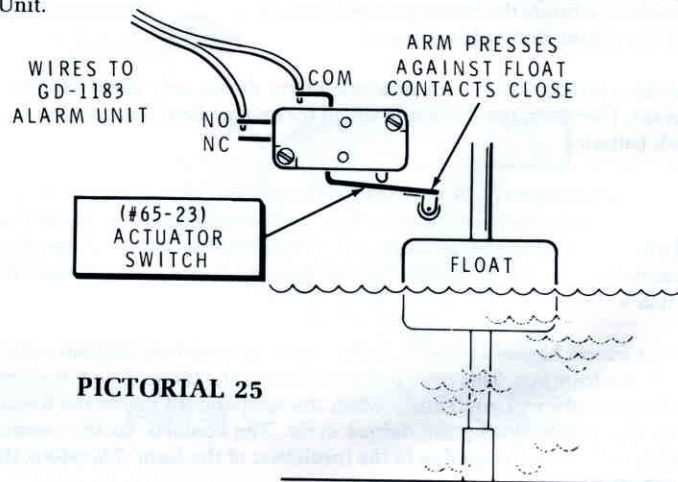

The application in Pictorial 26 uses a high temperature alarm made up of a heat sensor which acts as a normally-open switch. When you connect it to the Alarm Unit, the alarm remains off. However, when the temperature increases, the contacts will close and the alarm will turn on.

NOTE: HEATH Company will not be responsible for any damage due to malfunction of the Alarm GD-1183.

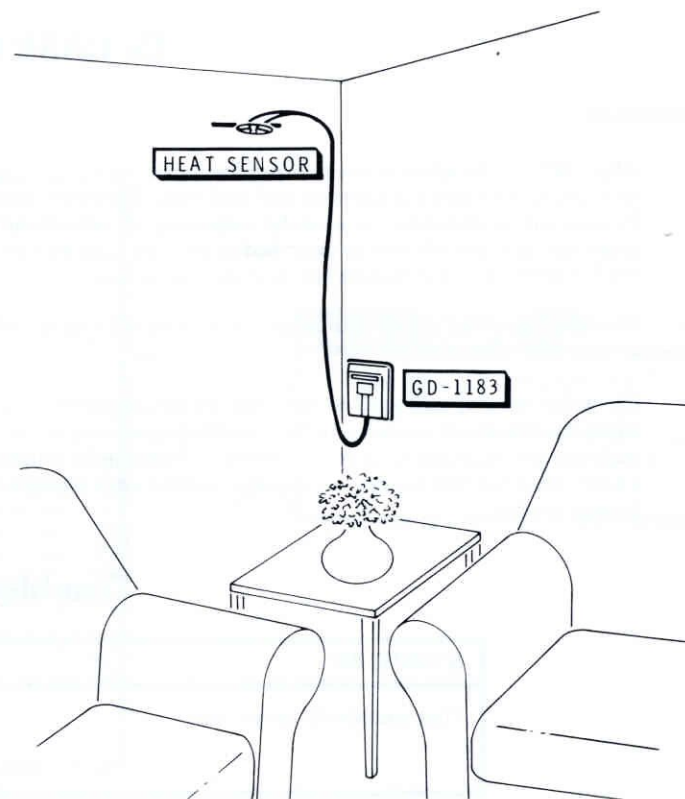

PICTORIAL 26

IN CASE OF DIFFICULTY

GENERAL

1. About 90% of the kits that are returned for repair, do not function properly due to poor connections and soldering. Therefore, many troubles can be eliminated by a careful inspection of connections to make sure they are soldered as described in the Soldering section of the Kit Builders Guide. Reheat any doubtful connections.
2. Check to be sure that all transistors are in their proper locations, and are installed correctly.
3. Check the value of each part. Be sure that the proper part has been wired into the circuit, as shown in the Pictorial diagram and as called out in the wiring instructions. It would be easy, for example, to install a 2200 Ω (red-red-red) resistor in a step that calls for a 220 Ω (red-red-brown) resistor.

4. Check all component leads connected to the circuit boards. Make sure the leads do not extend beyond the circuit board and make contact with other connections or parts.
5. Determine if the malfunction is in the Alarm Unit or in the sensors by repeating the "Initial Test." If it fails the test, the problem is in the Alarm Unit. If it passes the test, the problem is in the sensors, switches, or the wiring.

NOTE: In an extreme case where you are unable to resolve a difficulty, refer to the "Customer Service" information inside the rear cover of the Manual. Your Warranty is located inside the front cover of the Manual.

Troubleshooting Chart

SYMPTOM	POSSIBLE CAUSE
Unit completely inoperative.	<ol style="list-style-type: none"> 1. Batteries reversed. 2. Weak batteries. 3. Broken wires to battery lugs.

SYMPTOM	POSSIBLE CAUSE
Light is inoperative - audio is ok.	<ol style="list-style-type: none"> 1. LED reversed. 2. LED defective. (Check LED by shorting the nearest lead to lug 2 of SW1. If the light does not turn on, the LED is defective.)
Audio is inoperative - light is ok.	<ol style="list-style-type: none"> 1. Q3, Q4 are interchanged or installed backwards. 2. C4, C5 are interchanged. 3. C1, C6 are installed backwards.
Alarm will not operate at a fast rate.	<ol style="list-style-type: none"> 1. Q1, Q2 interchanged or installed backwards. 2. C2, C3 are interchanged.
Alarm operates at a slow rate continuously.	<ol style="list-style-type: none"> 1. Q1 is defective or resistors around Q1 are interchanged or wrong value.
Unit operates at a slow rate when sensor is installed in freezer.	<ol style="list-style-type: none"> 1. Thermal switch has not reached proper temperature to open its contacts. Wait approximately 10 minutes and try it again. 2. Defective thermal switch. 3. Cable between the thermal and door switches shorted.
Unit operates at a fast rate with door closed.	<ol style="list-style-type: none"> 1. Door switch wired incorrectly. 2. Switch button is not making contact with rubber foot. 3. Cable between door actuator and Alarm Unit shorted.

SPECIFICATIONS

Visual Alarm	LED — red flashes.
Audible Alarm	2-1/4" speaker, ≈2kHz.
Slow Alarm Rate	Approximately two beats per second.
Fast Alarm Rate	Approximately six beats per second.
Power Source	Two C-cell batteries.
Power Drain	Slow alarm <10mA. Fast alarm ≈25mA.
Housing Size	4-7/8" L × 3-5/8" W × 1-3/4" H. (125 × 93 × 43 mm)
Weight	0.6 lbs. (0.3 kg).
Sensors	Thermal Switch: Close at 23° F (−5° C) maximum. Open at 5° F (−15° C) minimum. Door Actuator Switch: N.C. (normally closed) contacts. Rain sensor: printed circuit board.

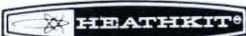

CIRCUIT DESCRIPTION

Refer to the schematic (Illustration Booklet, Page 7), as you read the following Circuit Description:

The alarm circuit uses two complementary multivibrators. Each multivibrator uses a PNP and NPN type transistor. Both multivibrator transistors Q1 and Q2, or Q3 and Q4, are briefly turned on to a saturated condition, and then remain off for a period determined largely by the coupling capacitor and the base resistor which discharges the capacitor.

The first multivibrator consists of Q1 and Q2 and lights the LED during the "on" time. Normally the "on" time is very short, but adding a larger capacitor and resistor (C3 and R4) in parallel with the coupling capacitor (C2), increases the time so that the flash is clearly visible.

The "off" time is infinite with the external switches (SW2 and SW3) open. Closing the thermostat places about 2 M Ω in the discharge circuit and causes a slow alarm rate. The door switch (SW2), lowers the discharge resistance to 1 M Ω and causes a faster alarm rate.

In the second multivibrator, consisting of Q3 and Q4, capacitor C5 reduces the sharp spikes from the inductive load. The base resistor (R7), is virtually grounded during the "on" time of the first multivibrator, and the second multivibrator operates during this time. When the first multivibrator is "off", the base resistor (R2), is essentially connected to the supply through the 3300 ohm resistor (R5), paralleling the LED. This causes a definite turnoff of the second multivibrator each time the first multivibrator is "off".

SEMICONDUCTOR CHART

COMPONENT	HEATH PART NO.	MANUFACTURERS PART NO.	BASE DIAGRAM
Q1, Q3	417-235	2N4121	
Q2, Q4	417-801	MPSA20	

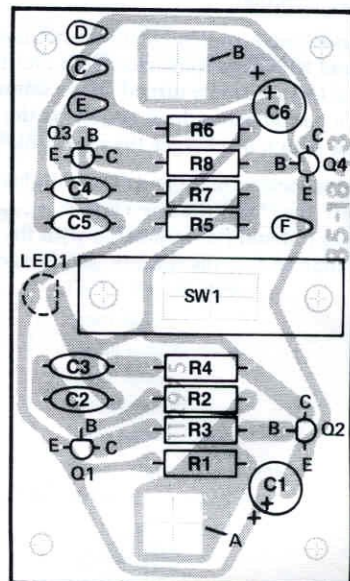
CIRCUIT BOARD
X-RAY VIEW

(shown from the foil side)

FOR PARTS REQUESTS ONLY

- Be sure to follow instructions carefully.
- Use a separate letter for all correspondence.
- Please allow 10 - 14 days for mail delivery time.

SEND TO:

DO NOT WRITE IN THIS SPACE**HEATH COMPANY**BENTON HARBOR
MICHIGAN 49022**ATTN: PARTS REPLACEMENT**Phone (Replacement parts only):
616 982-3571**INSTRUCTIONS**

- Please print all information requested.
- Be sure you list the correct **HEATH** part number exactly as it appears in the parts list.
- If you wish to prepay your order, mail this card and your payment in an envelope. Be sure to include 10% (25¢ minimum, \$3.50 maximum) for insurance, shipping and handling. Michigan residents add 4% tax.

- If you prefer COD shipment, check the COD box and mail this card. Total enclosed \$ _____ COD

NAME _____

ADDRESS _____

CITY _____

STATE _____ ZIP _____

The information requested in the next two lines is not required when purchasing nonwarranty replacement parts, but it can help us provide you with better products in the future.

Model # _____ Invoice # _____

Date Purchased _____ Location Purchased _____

LIST HEATH PART NUMBER	QTY.	PRICE EACH	TOTAL PRICE
TOTAL FOR PARTS			
HANDLING AND SHIPPING			
MICHIGAN RESIDENTS ADD 4% TAX			
TOTAL AMOUNT OF ORDER			

CUSTOMER SERVICE

REPLACEMENT PARTS

Please provide complete information when you request replacements from either the factory or Heath Electronic Centers. Be certain to include the **HEATH** part number exactly as it appears in the parts list.

Replacement parts are maintained specifically to repair Heath products. Parts sales for other reasons will be declined.

ORDERING FROM THE FACTORY

Print all of the information requested on the parts order form furnished with this product and mail it to Heath. For telephone orders (parts only) dial 616 982-3571. If you are unable to locate an order form, write us a letter or card including:

- Heath part number.
- Model number.
- Date of purchase.
- Location purchased or invoice number.
- Nature of the defect.
- Your payment or authorization for COD shipment of parts not covered by warranty.

Mail letters to: Heath Company
Benton Harbor
MI 49022
Attn: Parts Replacement

Retain original parts until you receive replacements. Parts that should be returned to the factory will be listed on your packing slip.

OBTAINING REPLACEMENTS FROM HEATH ELECTRONIC CENTERS

For your convenience, "over the counter" replacement parts are available from the Heath Electronic Centers listed in your catalog. Be sure to bring in the original part and purchase invoice when you request a warranty replacement from a Heath Electronic Center.

TECHNICAL CONSULTATION

Need help with your kit? — Self-Service? — Construction? — Operation? — Call or write for assistance. You'll find our Technical Consultants eager to help with just about any technical problem except "customizing" for unique applications.

The effectiveness of our consultation service depends on the information you furnish. Be sure to tell us:

- The Model number and Series number from the blue and white label.
- The date of purchase.
- An exact description of the difficulty.
- Everything you have done in attempting to correct the problem.

Also include switch positions, connections to other units, operating procedures, voltage readings, and any other information you think might be helpful.

Please do not send parts for testing, unless this is specifically requested by our Consultants.

Hints: Telephone traffic is lightest at midweek — please be sure your Manual and notes are on hand when you call.

Heathkit Electronic Center facilities are also available for telephone or "walk-in" personal assistance.

REPAIR SERVICE

Service facilities are available, if they are needed, to repair your completed kit. (Kits that have been modified, soldered with paste flux or acid core solder, cannot be accepted for repair.)

If it is convenient, personally deliver your kit to a Heathkit Electronic Center. For warranty parts replacement, supply a copy of the invoice or sales slip.

If you prefer to ship your kit to the factory, attach a letter containing the following information directly to the unit:

- Your name and address.
- Date of purchase and invoice number.
- Copies of all correspondence relevant to the service of the kit.
- A brief description of the difficulty.
- Authorization to return your kit COD for the service and shipping charges. (This will reduce the possibility of delay.)

Check the equipment to see that all screws and parts are secured. (Do not include any wooden cabinets or color television picture tubes, as these are easily damaged in shipment. Do not include the kit Manual.) Place the equipment in a strong carton with at least THREE INCHES of resilient packing material (shredded paper, excelsior, etc.) on all sides. Use additional packing material where there are protrusions (control sticks, large knobs, etc.). If the unit weighs over 15 lbs., place this carton in another one with 3/4" of packing material between the two.

Seal the carton with reinforced gummed tape, tie it with a strong cord, and mark it "Fragile" on at least two sides. Remember, the carrier will not accept liability for shipping damage if the unit is insufficiently packed. Ship by prepaid express, United Parcel Service, or insured Parcel Post to:

Heath Company
Service Department
Benton Harbor, Michigan 49022



HEATH COMPANY • BENTON HARBOR, MICHIGAN
THE WORLD'S FINEST ELECTRONIC EQUIPMENT IN KIT FORM

LITHO IN U.S.A.